

**MOBILIS**  
ELITE

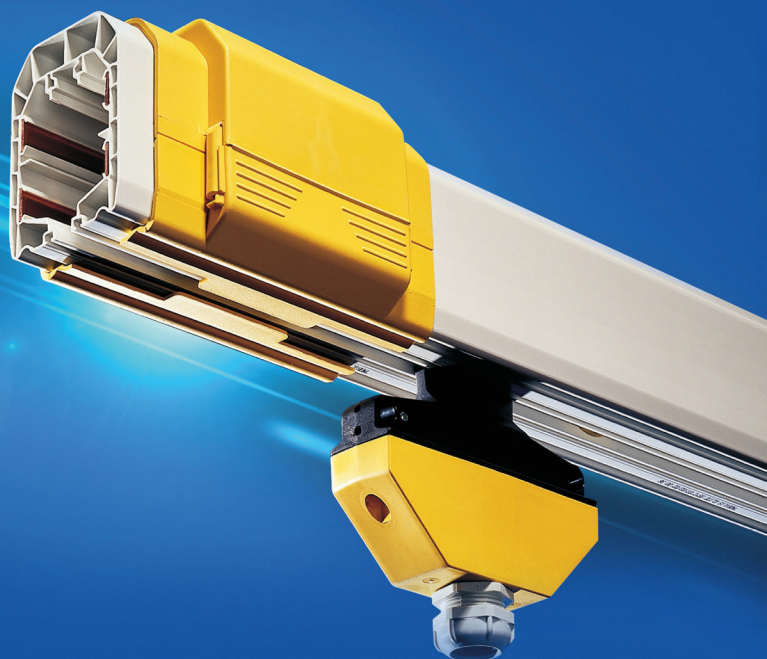

**MOBILIS**  
MOVIT

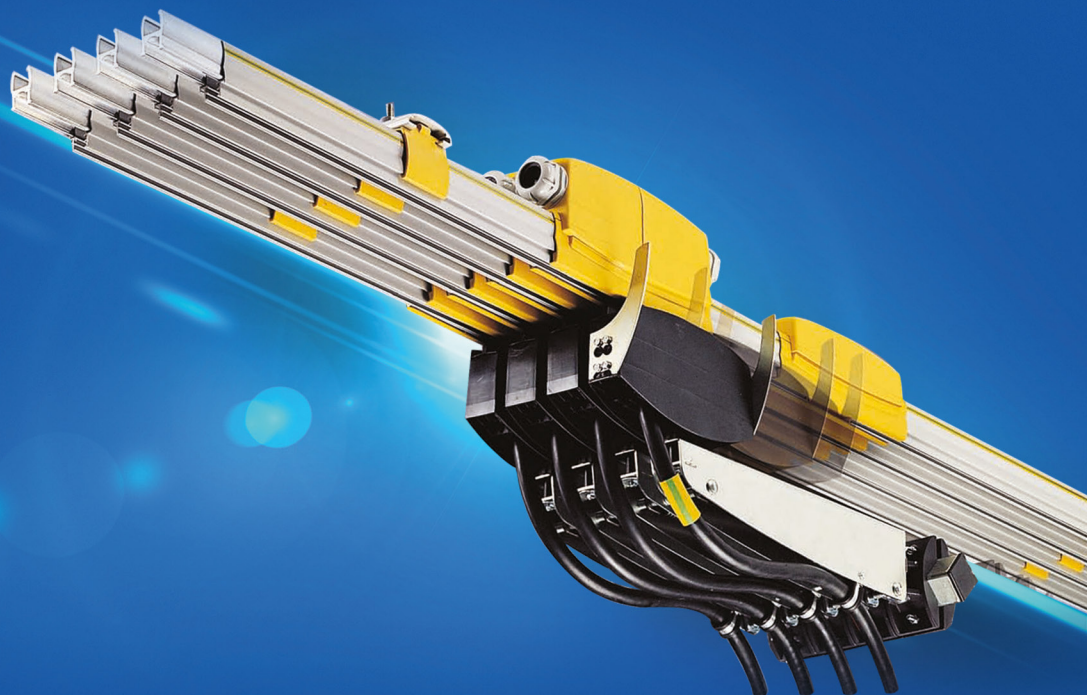

# Sommaire

## Introduction

Sélection du produit	6
Calcul de ligne	10

## Mobilis Elite

Présentation	17
Données techniques	20
Composants	31
Standard straight element	31
High temperature straight element	34
Straight element without earth marking	37
Straight element with protection lips	41
Covering flange	44
End-cap	47
Sliding hanger	49
Fixed hanger	52
Bracket	55
End-line feed	58
M25-M32 in-line feed	62
M40 in-line feed	67
Pre -mounted feed box on straight element	72
Introduction gate	76
Ventilation element	79
Expansion joint	82
Horizontal curve	87

Transfer elements	90
Circuit interruption element	94
Rigid trolleys	97
Simplified trolleys	103
Articulated trolley	107
Special trolley for transfer element	112
High speed trolley	116
Cleaning trolley	121
Standard carrier	124
Carrier with box	127
Special carrier for long transfer element	131
Switching finger	134
Set of 5 screws + nuts 20A - 100A	136
Set of feed connection for 5th pole	137
Set of 10 screws + 5 nuts 130A	138
Set of connection screws 160A	139
Set of connections for 200A 5 poles	140
Set of connection screws 200A	141
Set of 4 collector brushes	142
Set of 5 collector brushes	143
Brush for simplified trolley	144
Set of 5 cleaning brushes	145
Set of 2 special screws for fixed hangers	146
Set of 2 carrier rings	147
Cone for short transfer element	148
Cone for long transfer element	149

## Mobilis Movit

Présentation

{tttt □  
}

Données techniques	{tttt □ }
Composants	{tttt □ }
Rail	161
Connection	165
Covering flange	168
Feeding box	171
End-cap	175
Sliding hanger	178
Fixing clamp	182
Collector	186
Collector bracket	191
Bracket	194
Expansion joint	197
Circuit interruption element	200
Cable eye stiffeners for feed	203
Brush for preparation of rail ends	204
Contact lubricant	205
Replacement brush for collector	206
Single cleaning collector	207
Cleaning and grinding brushes	209
Kit for unclipping sliding hangers	210
Ice shield	211

## Gammes historiques

Composants	{tttt □ }
Mobilis Elite 200A non -reduced Earth	213
Obsolete range MOBILIS CE	216

Trolley with cable Mobilis CE	217
Standard brushes for carriage mobilis CE	218
Brushes of trolleys mobilis CE for lines with transfer element	219
Remote control brush Mobilis CE	220
Obsolete range MOBILIS UNIT	221
Brush for pantograph 100A Mobilis UNIT	222

# RELIABILITY, SAFETY, EASY USE, HIGH PERFORMANCE

## ... right out of the box!

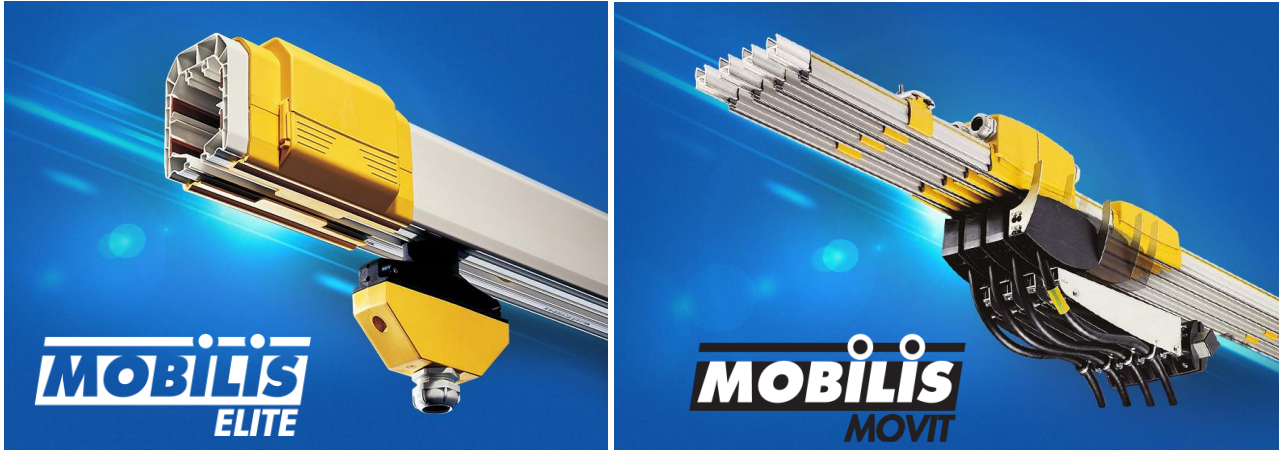

Pages of product selection

### OUTSTANDING ADVANTAGES:

- Quick and easy installation of Movit and Elite

- Modular elements available in several lengths
- Pre-assembled hangers
- Clipped-on mounting of lines in self-aligning hangers
- Safe and easy Elite connection by self-breaking screws guaranteeing tightening at optimum torque
- Large number of accessories quickly mounted, with no special tool
- All accessories are pre-assembled in the factory
- Current collector brushes of Elite, removable without uninstalling collector wiring
- Dust protection lips of Elite, pre-mounted in the factory for time saving on the site
- Elite rails with safety pins for direction and intensity

- Tried and tested safety ensured

- Complies with international standards (EN60204-32, CEI61439-6)
- Elite and Movit have IP23 protection index, which means that the equipment is protected so that people cannot access the dangerous sections, even under the rain
- Thousands of applications made safe by Mobilis worldwide over many years

- Reduced maintenance and exceptional operating life

- Wear parts size specially designed for long maintenance-free operating life
- Sturdy design, tried and tested over 40 years

- Tried and tested reliability

- Sturdy and tried and tested design of Elite and Movit
- Light-weight and more rigid cellular structure of Elite
- Qualification and endurance testing to requirements stricter than standards before placing on the market

- No expansion issues

- Issues of expansion differences in materials considered early at the design stage
- Long lengths of line with no expansion joint needed
- Expansion joints of innovative and compact design

- Developed to meet the needs on the field

- Special accessories available to meet field requirements (ventilation elements, circuit interruption, inlet gate, maintenance devices)
- Vertical and horizontal curves
- Elements for transfer
- Easy assembly of ergonomic range: quick and intuitive to learn, visual assembly instructions on rail for Elite
- Materials suitable for the various industrial environments

- Ancillary costs reduced

- Cost-effective modular system: replacement of one element/quick and easy extension
- Quick and easy mounting
- Quick customer help and decision with the Online Quote and Design Tool
- CAD 2D/3D File Package made available to reduce design & installation costs

- Long lengths of line feasible

- Unlimited lengths of line due to expansion joints

## 1. PRESENTATION

### Mobilis ELITE®

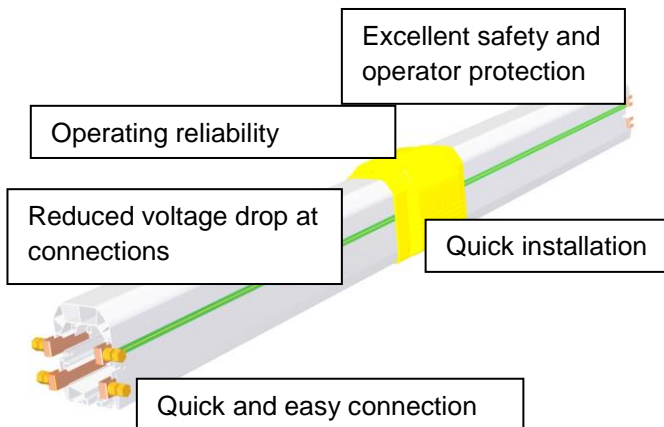

#### Multi-conductor Rail

Mobilis ELITE:

Quick installation:

Multiple pole lines with 4 or 5 pre-mounted conductors and many accessories to clip-on (no tools required)

Quick and easy connection:

Connection system with built-in self-breaking screws, guaranteeing tightening at optimum torque

Reduced voltage drop at connections:

The very large exchange surface, and tightening maintained at optimum torque allow reducing and controlling voltage drop

Excellent safety and operator protection:

The closed profile of the mounted line with the full set of accessories has a protection level of IP23, which means that the equipment is protected so that people cannot access the dangerous sections, even under the rain

Operating reliability: The current collectors, tested against requirements stricter than the standards, are designed to run for several thousand kilometers, providing reduced maintenance of facilities

Product selection

### Mobilis MOVIT®

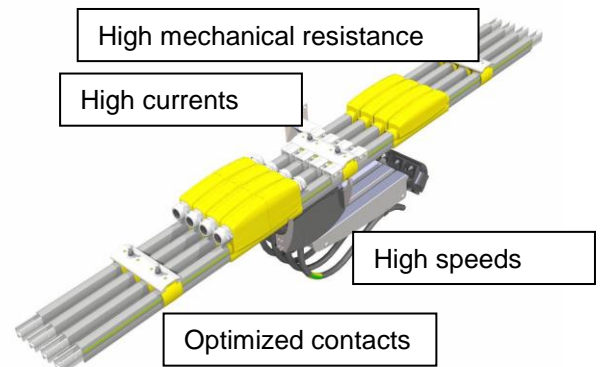

#### Single-conductor Rail

Mobilis MOVIT:

High speeds:

Up to 600m/min

High currents:

Up to 630A

High mechanical resistance:

H rigid profile and sturdy accessories, ideal where reliability, safety, and high performance are required

Optimized contact:

Collector contact under control due to provision for angular offset

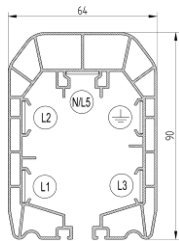

Number of poles: 4 or 5

Intensities: 12A, 20A, 40A, 60A,  
100A, 160A, 200A

Maximum operating voltage: 750V

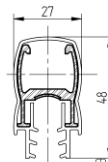

Number of poles: 1 to infinity

Intensities: 315A,  
450A, 630A

Maximum operating voltage: 750V

Protection Index IP23 according to EN60529  
Complies with Standards EN60439-2,  
EN60204-32, CEI61439-6

Protection Index IP23 according to EN60529  
Complies with Standards EN60439-2,  
EN60204-32, CEI61439-6

## INTRODUCTION :

As a specialist of electrical supply rail manufacturing for mobile equipment since the seventies, the FELS Company has perfect knowledge and experience of the needs of the integrators, installers, and end-users on this market worldwide, and of the special features of such devices. Its two product ranges, MOBILIS Elite and Mobilis Movit have been designed to meet the requirements of international standards. They offer a long operating life due to their robustness, with wear parts strengthened to reduce maintenance of facilities. The high quality of materials and the great care used for their workmanship also guarantee a long service life.

The high performance level achieved by all the ranges of rails results of the close contacts that Fels has maintained over the years with the many manufacturers, installers, and end-users of such equipment.

## CLIENT SERVICE:

In order to meet the increasing demand for services on the part of its clients, Fels has developed a capacity for listening and quick reaction within its organization. Each client is provided with permanent and personalized assistance and follow-up. We insist on maintaining close contact, in order to make the commercial and technical transactions, as much productive as possible, and leading to improved quality in the interest of both parties. Service quality is indeed recognized by clients as one of our main advantage.

## A BROAD RANGE OF REFERENCES:

Since it was launched, the Mobilis Elite electric rail has proved its efficiency in all sectors where top-quality mobile electrification is required. Fels has supplied its equipment to customers in myriad plants throughout Europe and the world, proving that this leading-edge equipment can be adapted to many applications: the car industry, aeronautics industry, chemicals, railways and energy industries – everywhere where travelling cranes are essential.

With its network of partners, selected because they share the Fels philosophy in terms of quality and service, Fels has broken into the market on all five continents, providing an efficient, reliable service for companies in all sectors. When it comes to services, Fels also supplies the energy right down the line !

## 2. DATA NEEDED TO SELECT EQUIPMENT

The following data must be known in order to define the intensity of a MOBILIS line:

Selection of product



- Maximum intensity in continuous operation, or failing this power and types of receivers (cage or slip-ring motors, electronic starters, resistors)
- Receiver start-up intensity
- Maximum ambient temperature
- Maximum clearance between a receiver and the nearest feeding point
- Permissible voltage and voltage drop in continuous operation and on start-up
- Type of current (frequency, voltage)
- Running cycle of the receiver (duty cycle, or operating time per 10-minute cycle).

In addition, review the following options to find out the most appropriate solution:

- Installation with more than 5 conductors: select Mobilis Movit or arrange 2 Elite lines in parallel
- Installations with curves and a radius shorter than 15m, or transfers between different circuits: select Mobilis Elite
- Installations with mobile speed greater than 180m/min: choose Mobilis Movit
- For all other configurations, calculate intensity to select the best equipment.

➔ All the above features along with the calculation of intensity (see below) will help you determine which range is most appropriate to your needs, Elite 12A-200A Range or Movit 315A-630A Range, The first selection criteria to be considered being the permissible current for Mobilis rails, which must be higher than the installation intensity, and the second criteria being the voltage drop involved.

You may also use the Online Calculation Tool on our website: [www.fels.fr](http://www.fels.fr)

The details above can also be used to fill out the online [Consultation Sheet](#) for assistance by our Engineering Office.

### 3. TECHNICAL DETAILS:

See [Technical data of Elite Range](#) 

See [Technical data of Movit Range](#) 

### 4. LINE CALCULATION:

See the section [Line calculation](#) 

### 5. OBSOLETE EQUIPMENT

See the section [Historical ranges](#) 

### 6. GUARANTEE

Our equipment is guaranteed one year against any material or manufacturing defect recognized by ourselves. As we are not responsible for its installation and operation, our guarantee covers only replacement or repair (at our own choosing) of the part recognized to be defective.

We do not accept responsibility for any defects arising from faulty supervision or maintenance. We also disclaim liability for any production stoppages that may result. Any arbitration shall be held in Strasbourg, even when several defendants are involved.



## LINE CALCULATION

To set the product and the intensity of the MOBILIS ELITE line, two parameters must be considered simultaneously:

- The voltage drop on line, which must be below the permissible value
- The product current capacity, which depends on the ambient temperature and on the duty cycle factor.

The following data must be known:

- Maximum intensity in continuous operation
- Type of receivers (cage or slip-ring motors, electronic starters, resistors)
- Receiver start-up intensity
- Maximum ambient temperature
- Maximum distance between a receiver and the nearest feeding point
- Permissible voltage and voltage drop in continuous operation and at start-up
- Type of current
- Running cycle of the receiver (duty cycle)

You can find out immediately the most suitable intensity by connecting to our website [www.fels.fr](http://www.fels.fr) and using our on-line "[Mobilis Price Calculator](#)".

For help in calculation by our Customer Service Department, fill out the [Consultation Sheet](#).

For manual calculation, follow the procedure below.

### 1. INTENSITY IN CONTINUOUS OPERATION

Take into account the number of receivers which run simultaneously and calculate the corresponding intensity:

$$I_N = I_1 + I_2 + \dots + I_n$$

The intensity may be worked out from the power of the receivers.  
In a three-phase system, this gives:

$$I_n = \frac{P_u}{\eta \cdot U \cdot \sqrt{3} \cdot \cos\varphi}$$

Where:

$I_n$  : absorbed current (in Amperes)

$P_u$  : power output of the receiver (in Watts)

$\eta$  : receiver efficiency (between 0.6 and 0.96 for a cage motor)

$U$  : operating voltage (in Volts)

$\cos \varphi$  : power factor

In the absence of information about running simultaneity of consumers, please refer to the table hereunder:

Number of consumers	For the whole hoisting devices			
	1 <sup>st</sup> motor	2 <sup>nd</sup> motor	3 <sup>rd</sup> motor	4 <sup>th</sup> motor
	Most powerful motor <sup>1</sup>	Motor, in power descending order <sup>1</sup>		
1	x	x		
2	x	x	x	
3	x	x	x	
4	x	x	x	x
5	x	x	x	x
2 hoisting devices working together	x	x	x	x

(1) For a drive through n motors of rated intensity  $I_n'$  in parallel, please consider  $I_n = n \times I_n'$ .

## 2. INTENSITY DURING THE START-UP PHASE

(2 seconds maximum)

Take into account the number of receivers starting up simultaneously and those already in operation, then calculate the corresponding intensity. When the start-up intensity is not known, find the approximate value as follows:

$$I_d = K \cdot I_n \text{ for a single receiver}$$

Where  $K = \frac{\text{Start-up current}}{\text{Nominal current}}$

(In general,  $K = 5$  to  $6$  for cage motors,  $K = 2$  for slipring motors,  $K = 2$  with frequency converter)

In the absence of information about running simultaneity of consumers, please refer to the table hereunder:

Number of consumers	For the whole hoisting devices							
	1 <sup>st</sup> moteur		2 <sup>nd</sup> motor		3 <sup>rd</sup> motor		4 <sup>th</sup> motor	
	$I_d$	$I_n$	$I_d$	$I_n$	$I_d$	$I_n$	$I_d$	$I_n$
1	x			x				
2	x			x		x		
3	x		x					
4	x		x			x		
5	x		x			x		x
2 hoisting devices working together	x		x			x		x

## 3. CALCULATION OF THE VOLTAGE DROP

Under normal running conditions, the voltage drop must be within 2% - 6% of the nominal voltage, according to the operating phase and the upstream/downstream features of the installation. The voltage drop between the origin of installation and any point of use shall not exceed the standard or set values for the applications.

Taking into account the mains voltage, the length of the section considered, the nominal intensity, start-up intensity and the impedance of the conductor selected, voltage drops can be worked out for the start-up phase and normal running phase using the following formulas:

Three-phase alternative current:  $\Delta U = \sqrt{3} \cdot Z \cdot L_t \cdot I$

Continuous current:  $\Delta U = 2 \cdot R \cdot L_t \cdot I$

Voltage drop in %:  $\Delta U\% = (\Delta U/U) \times 100$

I: current in continuous operation or at start-up, as appropriate (in Amperes)

Lt: length of the section considered (in m), taking Lt as per paragraph 4

Z: line impedance (in  $\Omega/m$ ) (see general technical data, paragraph 12 for Elite, 11 for Movit)

R: line resistance (in  $\Omega/m$ ) (see general technical data, paragraph 12 for Elite, 11 for Movit)

U: mains voltage (in Volts)

In the case of impulse running, the voltage drop can be quickly checked using the "continuous operation" and "start-up" graphs (see on the following pages).

When operating at 60Hz, overheating is similar, but voltage drop is greater:

For any given intensity:

$X_{60}$  being the reactance at 60Hz } calculate  $X_{60} = X_{50} \times \frac{60}{50}$  then re-calculate impedance at 60Hz  
 $X_{50}$  being the reactance at 50Hz }

$$Z_{60} = \sqrt{R^2 + X_{60}^2}$$

#### 4. FEEDING: LENGTH OF LINE SECTIONS

It is possible to have several feeding points along a line.

The judicious positioning of these points means voltage drop can be reduced.

If L is the line length, Lt is the maximum length of the section to be taken into account to work out the voltage drop:

One end-line feeding point

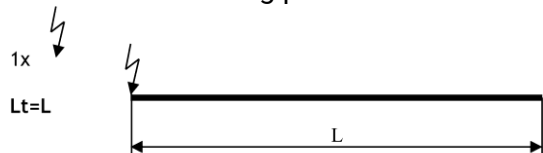

Three feeding points

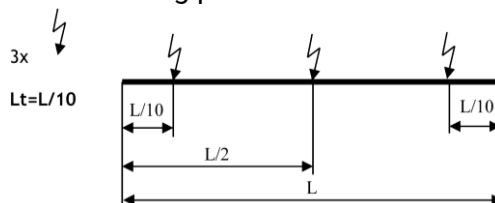

One midway feeding point

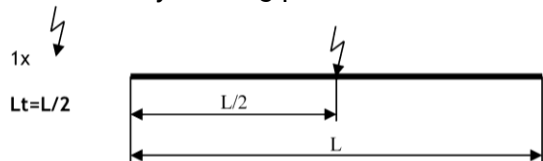

Four feeding points

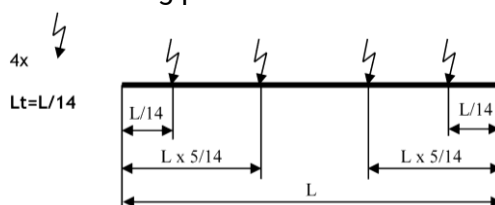

Two feeding points

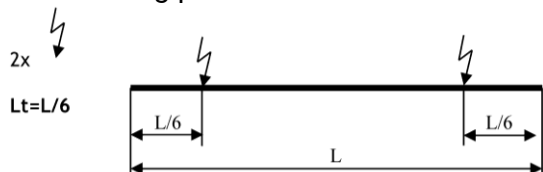

Five feeding points

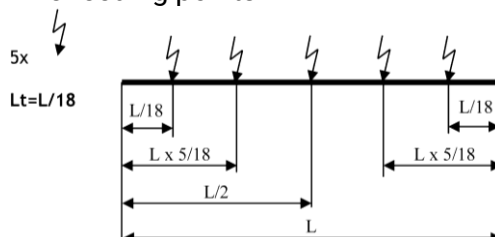

Mobilis line calculation

## 5. QUICK SELECTION CHART

### Continuous operation graph

Continuous operation under 400V at 50Hz, 35°C

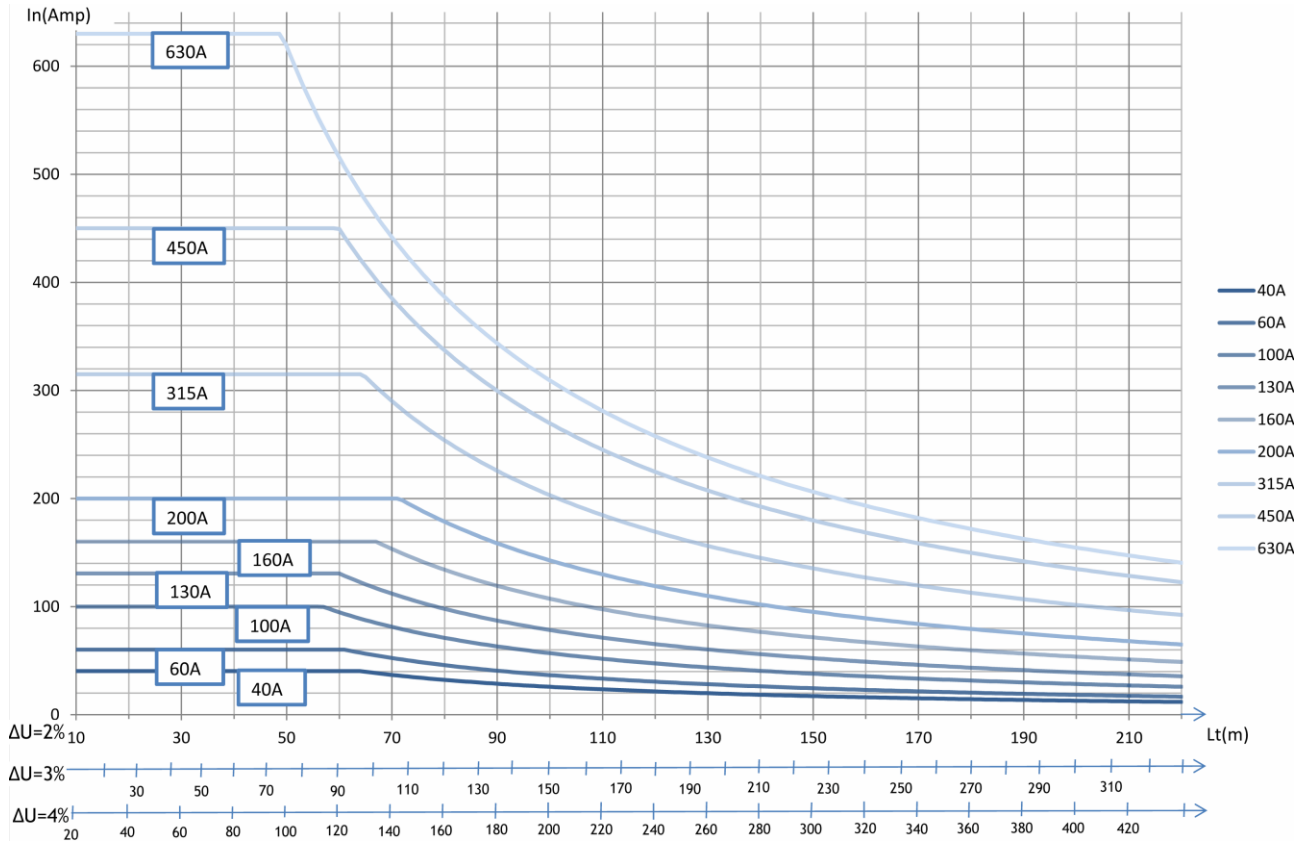

### Start-up phase graph

Starting : 2 seconds maximum under 400V at 50Hz, 35°C

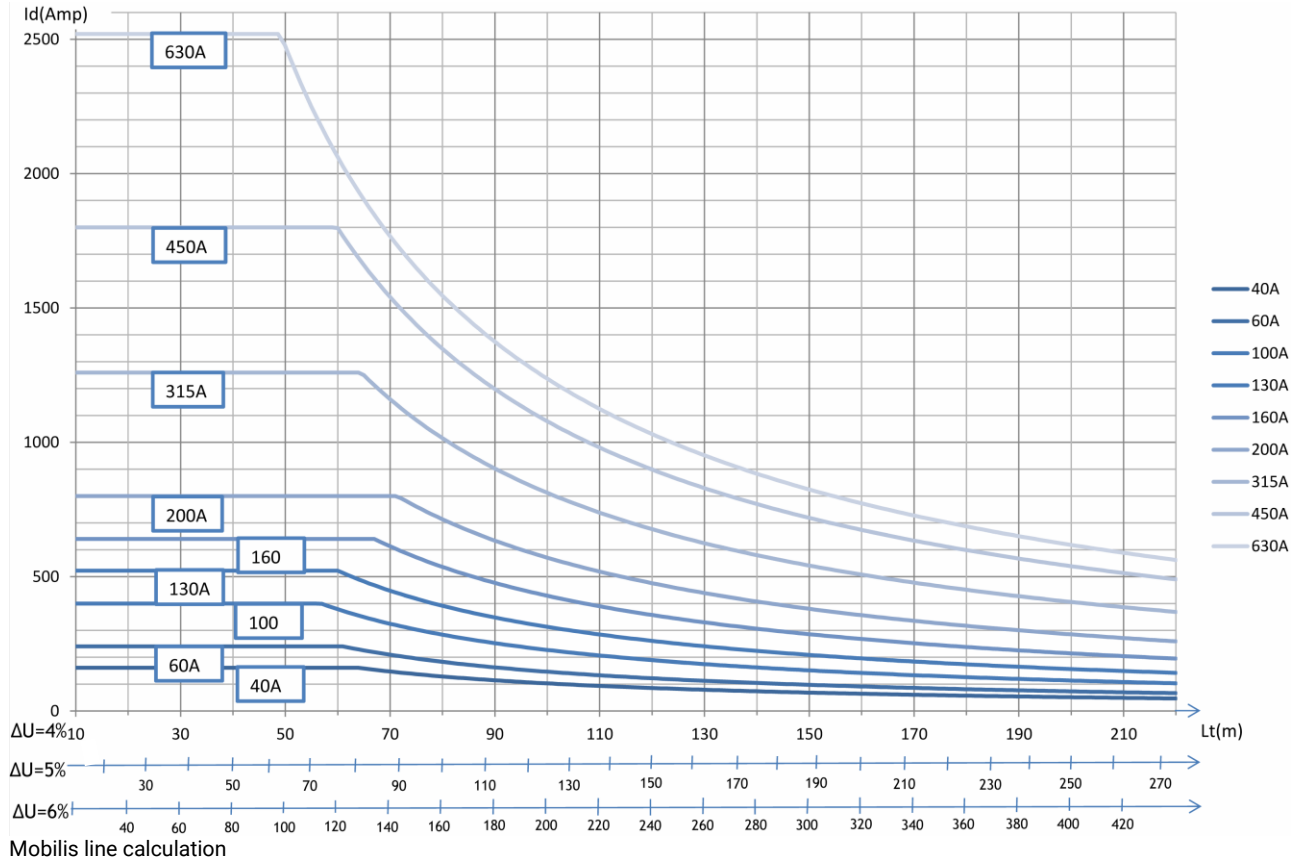

Mobilis line calculation

Quick Selection chart for Intensities 12A & 20A :

Continuous operation graph

Continuous operation under 400V at 50Hz, 35°C

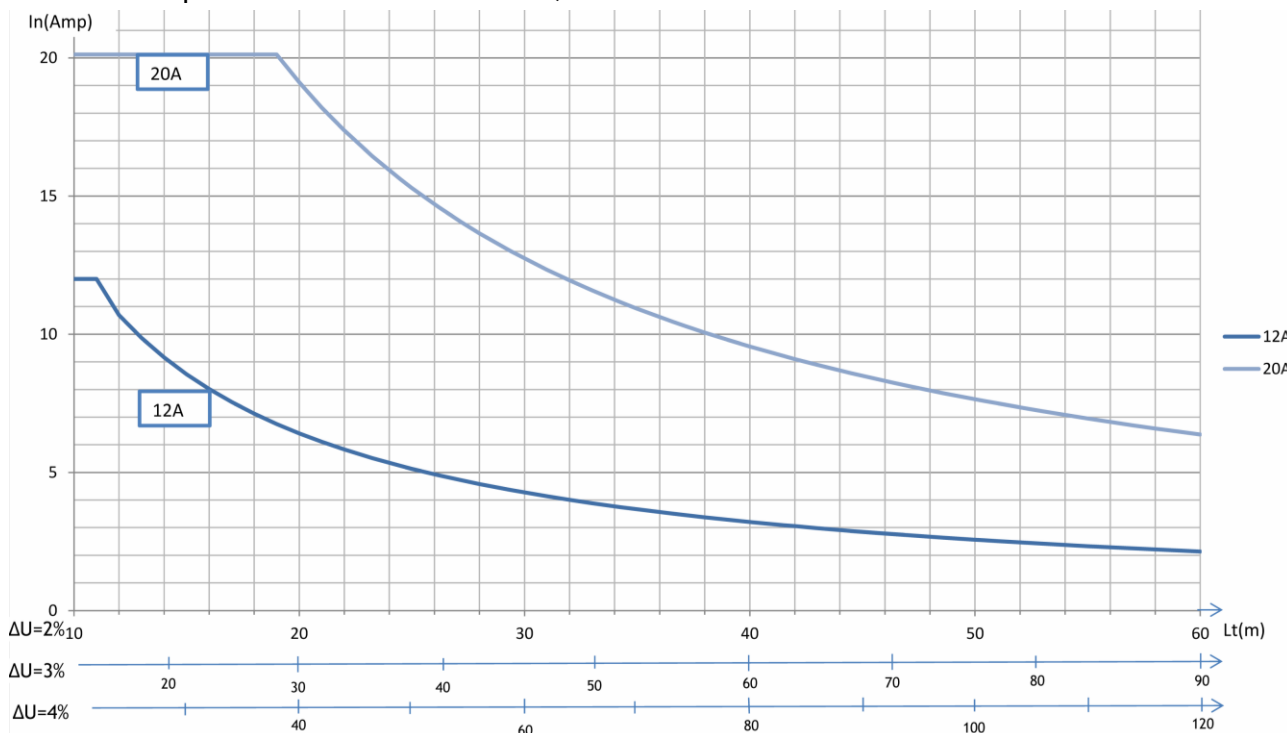

Start-up phase graph

Starting : 2 seconds maximum under 400V at 50Hz, 35°C

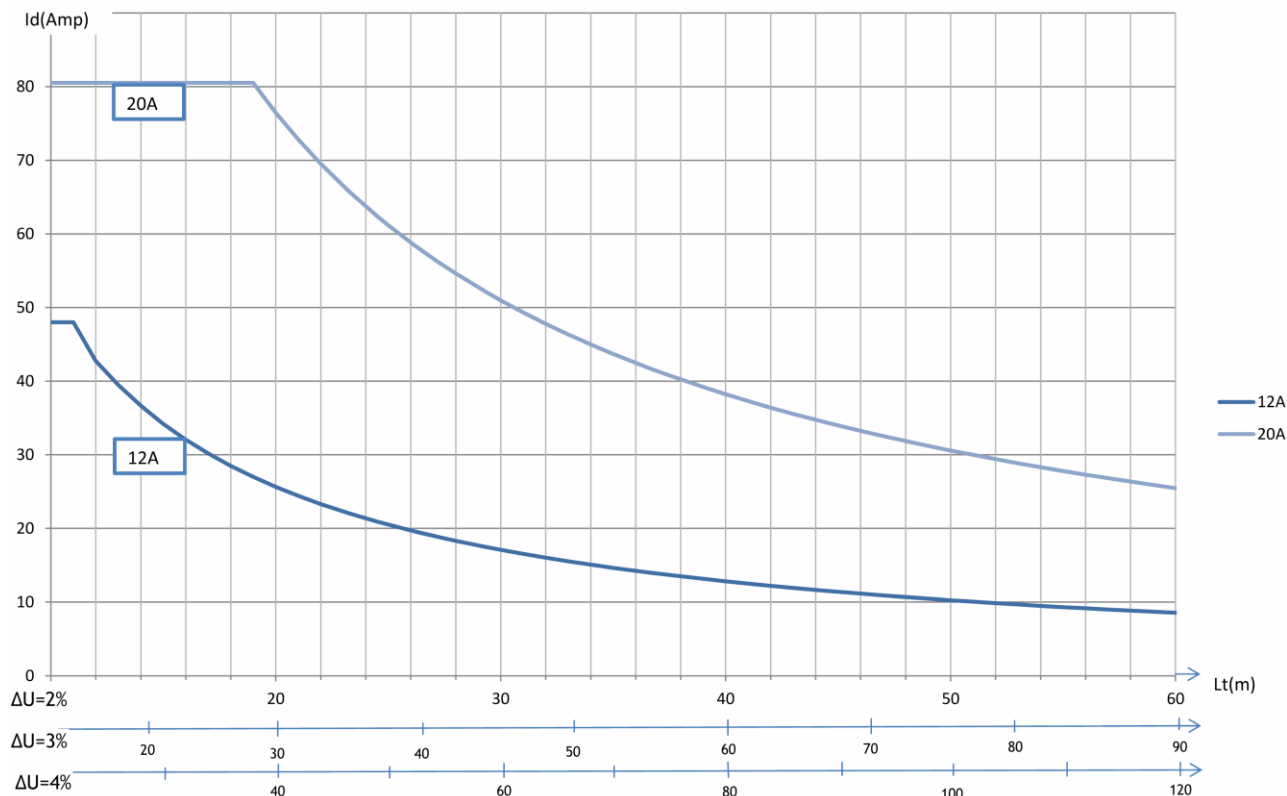

Mobilis line calculation



## 6. DUTY CYCLE FACTOR

The maximum permissible intensity in amperes depends on the maximum permissible ambient temperature for the feeding rail considered, on the ambient temperature, on the duty cycle factor (rate of equipment use over a short period), and on the Joule effect due to current carrying.

The duty cycle factor depends on the rate of equipment use, defined over ten-minute time periods and expressed in %, corresponds to the ratio running time over total time. A duty cycle factor of 80% means that the machine will be used 8 minutes per each 10-minute period.

If the calculated nominal intensity is lower or equal to the permissible intensity for a selected duty cycle factor at the maximum permissible ambient temperature, such intensity may be retained.

$$I_N \leq I_{FM}$$

An intensity lower than the nominal current may be retained if the requirements for voltage drop upon start-up, nominal voltage drop, and duty cycle factor are met.

The higher the operating temperature, the lower the maximum permissible current.

ELITE Permissible current:

Ambient temperature	Duty Cycle	Intensity					
		40A	60A	100A	130A	160A	200A
35°C	80%	72A	90A	117A	127A	162A	211A
40°C	80%	67A	86A	109A	117A	155A	195A
55°C	80%	48A	63A	86A	87A	131A	140A
35°C	100%	68A	85A	114A	120A	152A	184A
40°C	100%	64A	82A	106A	109A	145A	171A
55°C	100%	47A	61A	82A	83A	121A	126A

MOVIT Permissible current:

Ambient temperature	Duty Cycle	Intensity		
		315A	450A	630A
35°C	80%	420A	540A	638A
40°C	80%	384A	496A	580A
55°C	80%	275A	345A	420A
35°C	100%	395A	500A	570A
40°C	100%	360A	460A	530A
55°C	100%	255A	320A	385A

# MOBILIS

ELITE





# MOBILIS ELITE

The electrical supply rail Mobilis Elite meets the requirements of the most demanding manufacturers, installers, and end-users of mobile equipment: **higher safety, fast assembling, operation reliability, and easy maintenance of this electrical supply rail** for travelling cranes and other mobile equipment requiring mobile power socket.

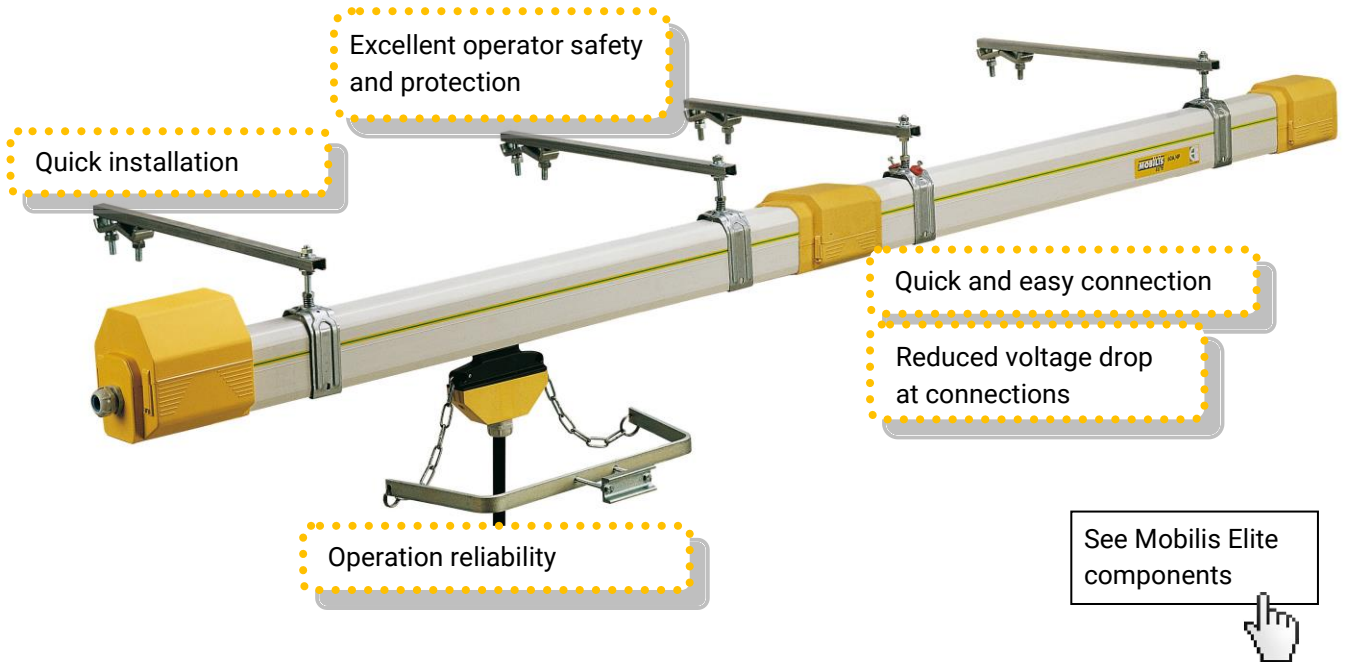

<u>Quick installation:</u> _____	Multiple pole lines with 4 or 5 pre-mounted conductors and many accessories to clip-on (no tools required)
<u>Quick and easy connection:</u> _____	Connection system with built-in self-breaking screws, guaranteeing tightening at optimum torque
<u>Reduced voltage drop at connections:</u> _____	The very large exchange surface, and tightening maintained at optimum torque allow reducing and controlling voltage drop
<u>Excellent operator safety and protection:</u> _____	The closed profile of the mounted line with the full set of accessories has a protection level of IP23, which means that the equipment is protected so that people cannot access the dangerous sections, even under the rain
<u>Operation reliability:</u> _____	The current collectors, tested against requirements stricter than the standards, are designed to run for several thousand kilometers, providing reduced maintenance of facilities

## 1. DETAILS OF PROFILE

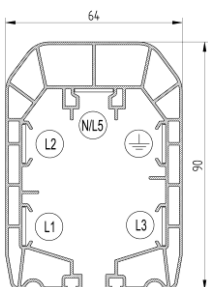

Number of poles: 4 or 5  
 Intensity: 12A, 20A, 40A, 60A, 100A, 160A, 200A  
 Maximum operating voltage: 750V

## OUTSTANDING ADVANTAGES

- Self-extinguishing closed PVC profile, of modern design
- Easy and quick mounting of the line in its suspensions
- Quick and reliable connection
- No preparation required
- Increased safety
- Modular and interchangeable

Mobilis Elite presentation

## 2. STANDARDS

- Protection level IP23 according to EN60529
- Meets the requirements of Standards EN60439-2, CEI61439-6 and EN60204-32

## 3. SPECIAL ELEMENTS AVAILABLE

- Transfer elements
- Curves
- Circuit interruption elements
- Inlet gates
- Ventilation elements
- Switching fingers
- Expansion joints
- Special trolleys and carriers
- Data transfer...

## 4. BENEFITS:

- Safe, quick, and fast clipped assembly of the elements in the self-aligning hangers.
- High range design and performance
- Large series manufacturing
- Modular and interchangeable: quick change of 4m elements. For extension of line or moving of feed points.
- Floating conductors fitted inside the profile to adjust to expansion differences of line synthetic material.
- Optimized cellular structures for excellent rigidity to the PVC, preventing access to dangerous inner sections, and minimal weight. Fels was the first to introduce the cellular structure of Mobilis Elite on the market.
- Closed system for maximum safety, protecting against access to dangerous sections, even under rain, according to international standards.
- Quick and reliable connection system by built-in removable self-breaking screws: guaranteeing tightening at optimum torque under all mounting conditions. Insulated junctions by covering flanges clipped on quickly and reliably (no tools).
- Reliable wiring thanks to earthing continuous marking, in-situ pole location, and safety pins.
- Tried and tested reliability of Mobilis Elite modular design with thousands of applications world-wide.
- Lines of long lengths made possible.
- Dust protection: time savings with factory-mounted protection lips.
- Voltage drops minimized due to the judicious choice of conductors' section, and of the low electrical resistance of the connections, stable over time. Software tool to help in calculation.
- Easier maintenance thanks to quick connection dismounting, to quick change of trolley brushes with no unwiring required (exclusive Mobilis Elite connector system), and the accessory "inlet gate" for easier access to the trolleys in a multi-equipment line, or in closed circuits.

## 5. [GENERAL TECHNICAL DATA](#)

See the related section  
(Uses, operating limits, ...)

## 6. [COMPONENTS](#)

See the related section  
(Straight elements, feed boxes, hangers, accessories...)

## 7. [DOWNLOADS](#)

See website. <http://catalogue.fels.fr/en/mobilis-elite/downloads>  
(Consultation Sheet, Assembly Instructions, CAD File Package)

## 8. GUARANTEE

Our equipment is guaranteed one year against any material or manufacturing defect recognized by ourselves. As we are not responsible for its installation and operation, our guarantee covers only replacement or repair (at our own choosing) of the part recognized to be defective.

We do not accept responsibility for any defects arising from faulty supervision or maintenance. We also disclaim liability for any production stoppages that may result. Any arbitration shall be held in Strasbourg, even when several defendants are involved.

Mobilis Elite presentation

# Mobilis ELITE – Technical Data



See related sections  
for special items

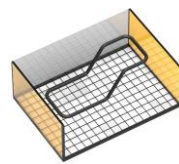

Curves

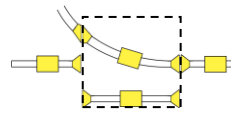

& Transferts

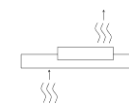

Ventilation,

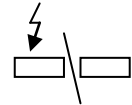

circuit  
Interruption

## 1. APPLICATIONS

The electrical supply rails with mobile socket are generally used for the electrification of travelling cranes, cranes and hoists, narrow-aisle stores, work station equipment (tasksaver systems), elements of electric hoisting equipment, theater stages, sewage treatment and composting equipment, and other diverse applications, inside and outside.

## 2. GENERAL TECHNICAL DATA:

### Rated operational intensity:

The MOBILIS ELITE lines are available in several intensities 20 A, 40 A, 60 A, 100 A, 130 A, 160 A and 200 A.

### Number of poles:

The MOBILIS ELITE lines are available in 4-pole or 5-pole version.

The ground conductor (PE) is marked on the line by a green-yellow band.

The neutral conductor (N), when present, is located in the top section of the casing.

The phases (L1, L2 and L3) are located as shown on the diagram opposite.

### Rated operational and insulation voltage:

750 V alternative, 50 Hz for standard version

440 V alternative, 50 Hz for high-temperature version

### Temperature of use:

-30°C to +55°C in the standard version, -30°C to +75°C in the high temperature version.

### 3. ENVIRONMENT:

Category 3 of ISO 2081 (outside mild), inside, outside use under rain or dust. A version with 600h resistance under saline mist is available. Please inquire.

Inside      Outside      Dust<sup>(1)</sup>      With snow      Low Temperatures<sup>(1)</sup>      Rain



(1) With protective lips for dust and special trolley for low temperatures

The Mobilis Elite feeding system is exclusively designed to run with opening of the casing facing downwards.

Validate suitability of the product to run in unfavorable environmental conditions (e.g. humid air flow, steam, frost...).

An unfavorable environment brings the following risks:

Legende :    +++    High risks  
               ++    Moderate risks  
               +    Low risks

Risk \ Environment	Reduction of insulation distances	Corrosion of metal parts (incl. connectors)	Losses of contact	Damage to thermoplastics	Disruption movements of mobile elements (trolleys, expansion joints)	Recommendations
Humidity	+++	++	+++	/	/	Ventilation element Collector with increased strength Cleaning trolleys
Outside use	/	+	+	+	/	Ventilation element If high UV environment, -High temperature range -Shelter (protective roof)
Dust	+	/	+++	/	/	Dust protection lips Cleaning trolleys
Frost, snow, ice	++	/	+++	/	+++	Increased strength collector Shelter (protective roof)
Inland port	+++	++	+++	/	/	Increased strength collector Cleaning trolleys
Marine environment	+++	+++	+++	/	/	Increased strength collector Cleaning trolleys Strengthened surface treatment (please inquire)
Chemical environment	+++	+++	+++	+ / +++	/	Check appropriate use of materials in conjunction with products (please inquire) Increased strength collector Cleaning trolleys Strengthened surface treatment (please inquire)

Mobilis Elite Technical Data

## 4. APPLICABLE STANDARDS:

The Mobilis Elite range has been designed to meet Standards EN60439-2, EN60204-32 and CEI61439-6. It bears the **CE** marking.

## 5. PROTECTION INDEX:

A mounted line with the full set of accessories has a protection level of IP23 according to EN60529, with no lips or with dust protection lips.

Caution: If one accessory is removed, the level of protection is eliminated.

IP2X means that the equipment is protected so that people cannot access the dangerous sections, i.e. it is impossible to introduce a standard test finger of Ø12 mm with an effort of 10 N. The equipment is also protected against solid foreign bodies, i.e. it is not possible to introduce a metal sphere of Ø12.5 mm with an effort of 30 N.

IPX3 means that the equipment is protected against rainwater falling at a maximum angle of 60° in relation to the vertical plane.

The Mobilis Elite range is designed for both inside and external use.

If a Mobilis Elite line is used in an area open to the public, additional safety measures should be installed (protection level IP4X required according to EN60204-32).

## 6. INSULATION DISTANCES:

The insulation distance between conductors or between conductors and accessible parts:

- Distance in the air: 10 mm min.
- Creepage distance: 30 mm min. (according to EN60204-32)

## 7. FLAME RESISTANCE:

All materials used to build Mobilis Elite lines are self-extinguishing; they pass successfully glowing/hot line tests under 960°C for elements in contact with live parts and V-0 according to UL-94.

## 8. SAFETY PINS

Line: to prevent mounting errors, 2 line elements with consecutive intensities cannot be assembled on the same line.

Identification of ground conductor: The ground conductor (PE) is marked on the line with a green-yellow band.

The connecting points on the line and the collecting trolleys are marked.

Trolley: with the safety pin system, it is not possible to insert a trolley into the line incorrectly, leading to a phase-earth connection.

## 9. SPACE REQUIREMENTS:

In addition to the space required for the various components (see in this section), make provision for mounting/dismounting of electrical wiring.

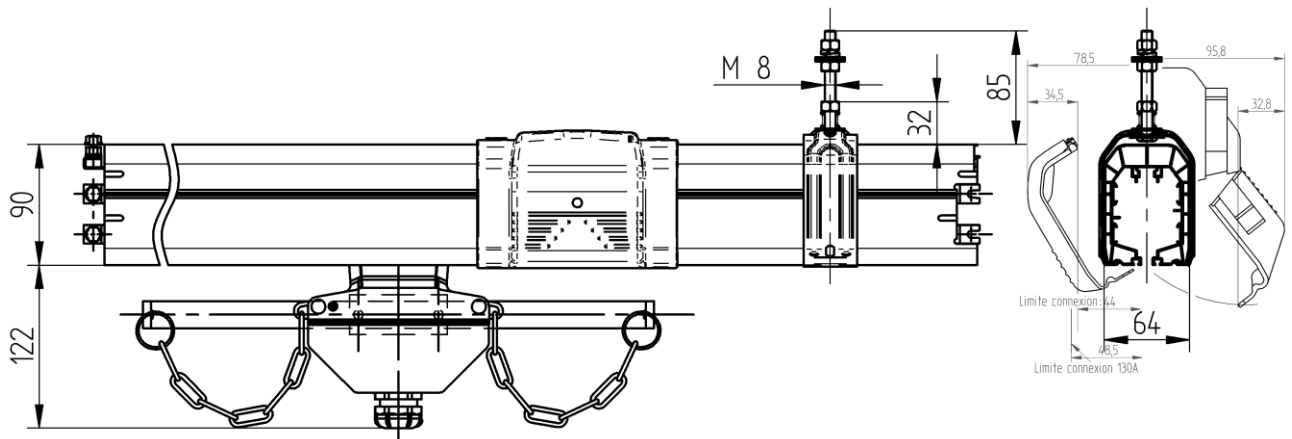

## 10. PROTECTION AGAINST FORGETTING:

Any connection, not fully established, prevents closing of covering flange, or of end-cap due to the self-breaking screws.

## 11. OPERATING LIFE - ENDURANCE

The lines and accessories are built to withstand several years of use in a normal industrial environment. The current collectors are designed to run for several thousand kilometers (see the Maintenance section for recommended service schedule).

## 12. RESISTANCE, REACTANCE, AND IMPEDANCE UNDER NORMAL CONDITION

Impulse running:

When the rush of current is of short duration followed by long rest periods, the figures in the table below can be used.

The value of the resistance R, reactance X and impedance Z at 50 Hz at ambient temperatures of 20°C and 35°C (short period current): the figures in the table are given in mΩ/m.

Intensity	12A	20A	40A	60A	100A	130A	160A	200A-TR
R <sub>20</sub> or R at 20°C	34,3	7,4	1,6	1,1	0,72	0,52	0,36	0,26
R (at 35°C)	35,8	8,1	1,69	1,16	0,76	0,55	0,38	0,27
R at 40°C	36,3	8,4	1,72	1,19	0,78	0,56	0,39	0,28
X	3,7	8,93	0,58	0,48	0,28	0,21	0,20	0,17
Z <sub>20</sub> or Z at 20°C	34,5	11,6	1,7	1,2	0,77	0,56	0,41	0,31
Z (at 35°C)	36	12,1	1,78	1,26	0,81	0,59	0,43	0,32
Z at 40°C	36,5	12,2	1,82	1,28	0,82	0,60	0,44	0,33

Intensive running:

The value of the resistance R, the reactance X and the impedance Z at 50 Hz according to the ambient temperature and taking into account the Joule effect for the different ratings carried by their nominal intensity and for a duty cycle as per paragraph below (\* = Fm<100%).

The figures in the table should be multiplied by  $10^{-3}$  to obtain  $\Omega/m$ .

Ambient temperature			25°	30°	35°	40°	45°	50°	55°	60°	65°	70°	75°
20A	R	standard	8,8	9	9,3	9,6	9,9	10*	10*				
		H.T.						10,1	10,5	10,8	10,8*	10,8*	10,8*
	X		8,93	8,93	8,93	8,93	8,93	8,93	8,93	8,93	8,93	8,93	8,93
	Z	standard	12,5	12,7	12,9	13,1	13,3	13,4*	13,4*				
H.T.							13,5	13,8	14	14*	14*	14*	
40A	R	standard	1,77	1,81	1,84	1,88	1,91	1,95	1,98				
		H.T.								2,01	2,05	2,08	2,09*
	X		0,58	0,58	0,58	0,58	0,58	0,58	0,58	0,58	0,58	0,58	0,58
	Z	standard	1,86	1,9	1,93	1,96	1,99	2,03	2,06				
H.T.									2,09	2,13	2,16	2,17*	
60A	R	standard	1,22	1,24	1,26	1,28	1,31	1,33	1,33*				
		H.T.							1,35	1,39	1,4*	1,4*	1,4*
	X		0,48	0,48	0,48	0,48	0,48	0,48	0,48	0,48	0,48	0,48	0,48
	Z	standard	1,31	1,33	1,35	1,37	1,4	1,41	1,41*				
H.T.								1,43	1,47	1,48*	1,48*	1,48*	
100A	R	standard	0,868	0,885	0,885*	0,885*	0,885*	0,885*	0,885*				
		H.T.			0,902	0,919	0,931*	0,931*	0,931*	0,931*	0,931*	0,931*	0,931*
	X		0,28	0,28	0,28	0,28	0,28	0,28	0,28	0,28	0,28	0,28	0,28
	Z	standard	0,91	0,926	0,926*	0,926*	0,926*	0,926*	0,926*				
H.T.				0,942	0,959	0,970*	0,970*	0,970*	0,970*	0,970*	0,970*	0,970*	
130A	R	standard	0,595	0,599*	0,599*	0,599*	0,599*	0,599*	0,599*				
		H.T.						0,630*	0,630*	0,630*	0,630*	0,630*	0,630*
	X		0,21	0,21	0,21	0,21	0,21	0,21	0,21	0,21	0,21	0,21	
	Z	standard	0,63	0,634*	0,634*	0,634*	0,634*	0,634*	0,634*				
H.T.							0,663*	0,663*	0,663*	0,663*	0,663*	0,663*	
160A	R	standard	0,43	0,435*	0,435*	0,435*	0,435*	0,435*	0,435*				
		H.T.			0,446	0,455	0,457*	0,457*	0,457*	0,457*	0,457*	0,457*	0,457*
	X		0,2	0,2	0,2	0,2	0,2	0,2	0,2	0,2	0,2	0,2	
	Z	standard	0,474	0,479*	0,479*	0,479*	0,479*	0,479*	0,479*				
H.T.				0,489	0,497	0,499*	0,499*	0,499*	0,499*	0,499*	0,499*	0,499*	
200A-TR	R	standard	0,298	0,303*	0,303*	0,303*	0,303*	0,303*	0,303*				
		H.T.						0,318*	0,318*	0,318*	0,318*	0,318*	0,318*
	X		0,17	0,17	0,17	0,17	0,17	0,17	0,17	0,17	0,17	0,17	
	Z	standard	0,343	0,347*	0,347*	0,347*	0,347*	0,347*	0,347*				
H.T.							0,36*	0,36*	0,36*	0,36*	0,36*	0,36*	



### 13. VALUE OF THE RESISTANCE R AND OF THE RESISTANCE X OF FAULT LOOP:

See EN60439-2 and CEI61439-6, below data for the application of the impedance method:

FAULT LOOP Characteristics ( $\Omega/m$ )	Intensity		
	130A	160A	200A - TR
$R_{b20ph\ ph}$	0,00101	0,000699	0,000505
$R_{b20ph\ N}$	0,00101	0,000699	0,000505
$R_{b20ph\ PE}$	0,00101	0,001048	0,000757
$R_{bph\ ph\ (1)}$	0,00124	0,000865	0,000613
$R_{bph\ N\ (1)}$	0,00124	0,000865	0,000613
$R_{bph\ PE\ (1)}$	0,00124	0,001297	0,000919
$X_{bph\ ph}$	0,000271	0,000271	0,000271
$X_{bph\ N}$	0,000271	0,000271	0,000271
$X_{bph\ PE}$	0,000271	0,000271	0,000271

(1) at 35°C ambient temperature and maximal rated current.

Protection against short-circuits:

For intensities  $\leq 130A$ ,  $I_{cw} < 10kA$ .

For intensities 160A and 200A TR:  $I_{pk} = 11kA$ .

### 14. INTENSITY ACCORDING TO DUTY CYCLE:

ambient Temperature	Duty Cycle Factor	Intensity					
		40A	60A	100A	130A	160A	200A
35°C	80%	72A	90A	117A	127A	162A	211A
40°C	80%	67A	86A	109A	117A	155A	195A
55°C	80%	48A	63A	86A	87A	131A	140A
35°C	100%	68A	85A	114A	120A	152A	184A
40°C	100%	64A	82A	106A	109A	145A	171A
55°C	100%	47A	61A	82A	83A	121A	126A

## 15. DOWNGRADING ACCORDING TO TEMPERATURE:

You may use the [Online calculation Tool](#) to calculate the values according to the maximum temperature.

Or find out the maximum permissible duty cycle factor in the table below:

If, for a given intensity, Duty cycle is higher than the value specified, it is necessary to select a higher intensity.

Intensity	20A		40A		60A		100A		130A		160A		200A-TR	
	standard	HT	standard	HT	standard	HT	standard	HT	standard	HT	standard	HT	standard	HT
Rated Current	20A	20A	40A	40A	60A	60A	100A	100A	130A	130A	160A	160A	200A	200A
-30 to 25°C	100%	100%	100%	100%	100%	100%	100%	100%	100%	100%	100%	100%	100%	100%
30°C	100%	100%	100%	100%	100%	100%	100%	100%	88%	100%	95%	100%	100%	100%
35°C	100%	100%	100%	100%	100%	100%	100%	100%	74%	100%	80%	100%	85%	100%
40°C	100%	100%	100%	100%	100%	100%	100%	100%	60%	100%	75%	100%	75%	100%
45°C	100%	100%	100%	100%	100%	100%	85%	100%	48%	84%	65%	87%	65%	93%
50°C	100%	100%	100%	100%	100%	100%	65%	100%	37%	69%	60%	70%	55%	74%
55°C	100%	100%	100%	100%	100%	100%	50%	100%	26%	56%	45%	54%	45%	57%
60°C		100%		100%		100%		100%		43%		41%		43%
65°C		59%		100%		100%		70%		32%		28%		30%
70°C		33%		100%		51%		50%		23%		19%		20%
75°C		18%		37%		12%		40%		16%		13%		14%

If not, refer to the following table for Elite 100% Duty Cycle Factor:

When the line carries a permanent current  $I_N$  (duty cycle factor 100%), it may be necessary to downgrade the intensities according to the temperature.

If  $I_G$  is the intensity of the rail and  $f$  is the correction factor defined in the table below, the new maximum permissible intensity  $I_{adm}$  will be:

Intensity	12A		20A		40A		60A		100A		130A		160A		200A-TR	
	standard	HT	standard	HT	standard	HT	standard	HT	standard	HT	standard	HT	standard	HT	standard	HT
Rated Current	12A	12A	20A	20A	40A	40A	60A	60A	100A	100A	130A	130A	160A	160A	200A	200A
-30 à 25°C	1	1	1	1	1	1	1	1	1	1	1	1	1	1	1	1
30°C	1	1	1	1	1	1	1	1	1	1	0,98	1	0,99	1	0,99	1
35°C	1	1	1	1	1	1	1	1	1	1	0,92	1	0,95	1	0,92	1
40°C	0,94	1	1	1	1	1	1	1	1	1	0,83	1	0,91	1	0,86	1
45°C	0,86	1	1	1	1	1	1	1	0,97	0,98	0,75	0,95	0,86	0,96	0,78	0,98
50°C	0,79	0,95	0,95	1	1	1	1	1	0,90	0,93	0,68	0,89	0,80	0,91	0,70	0,92
55°C	0,70	0,88	0,85	1	1	1	1	1	0,82	0,87	0,62	0,84	0,75	0,85	0,63	0,86
60°C		0,80		1		1		1		0,80		0,77		0,79		0,80
65°C		0,73		0,92		1		0,99		0,73		0,71		0,72		0,73
70°C		0,66		0,82		1		0,89		0,66		0,63		0,64		0,65
75°C		0,57		0,71		0,89		0,77		0,57		0,55		0,56		0,56

Mobilis Elite Technical Data

The intensity selected may be retained if the current in the line (IN) is lower than or equal to the permissible intensity ( $I_{adm}$ ) :

$$I_N \leq I_{adm}$$

## 16. [LINES CALCULATION](#)

See related section

(Data required for calculation, calculation method, charts...)

## 17. [ONLINE CALCULATION TOOL](#)

See <http://www.fels.fr/extranet/>

(Online calculation with intensity suggested based on data submitted)

## 18. [COMPONENTS](#)

See related section

(Straight elements, trolleys, feeding boxes...)

## 19. [ASSEMBLY INSTRUCTIONS](#)

See related section

## 20. SPECIAL RULES FOR STRAIGHT ELEMENTS WITH RIGID WIRING:

Reminder: Under normal conditions, no expansion joint is required for the installations according to the table below.

Intensity	20A	40A	60A	100A
Max. length of line without expansion joint	140m	150m	150m	150m

However, in some cases the feeding boxes are connected with rigid cables preventing expansion, which should then be considered as anchoring points. If such is the case, the following rules shall apply.

### Rules :

#### 1. Placement of Fixed Hanger:

The anchoring points are to be located on the line element which is the closest to the connecting box.

If some highly rigid cables are used preventing expansion, the anchoring points shall be located close to line feeding:

#### 2. End-line Feeding

For lines longer than the lengths in the below table, an expansion joint will be required:

Intensity	12-20A	40A	60A	100A	130A	160A	200A-TR
Maximum Length	62m	76m	62m	52m	40m	35m	30m

If end-line feeding uses rigid cables and an expansion joint:

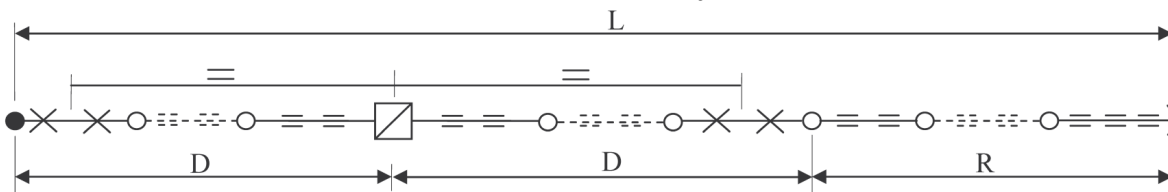

Intensity	L maxi	R	R maxi	D	D maxi
12A to 100A	146m	$(L + 24) / 2$	70m	$(L - R) / 2$	38m

### 3. In-line feeding

When feeds with rigid cables are located close to the anchoring points, the standard rules apply. Otherwise, lengths without expansion joints are limited to 30m for in-line feeds between two anchoring points. Beyond this, an expansion joint is required:

a) Without expansion joint :

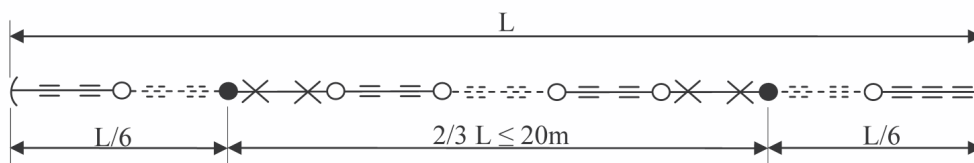

Intensity	20A to 100A
L maxi	30m

b) With only 1 expansion joint :  $30m < L < 150m$

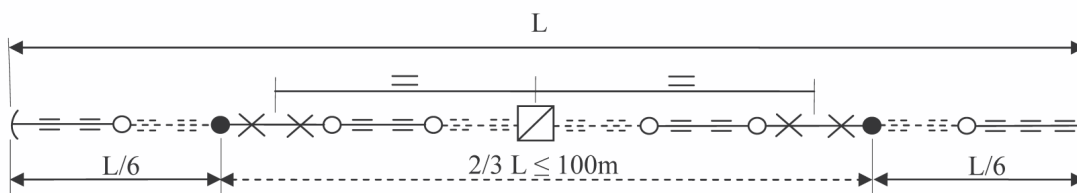

Intensity	20A to 100A
L maxi	150m

a) With 2 expansion joints :  $150m < L < 300m$

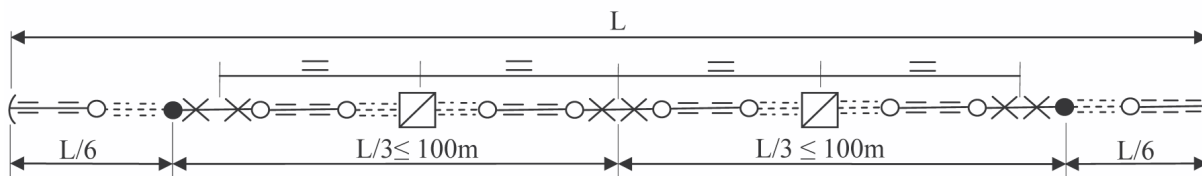

Intensity	20A to 100A
L maxi	300m

#### Key :

- × Fixed-hanger
- Feed-box
- = Sliding-hanger
- Expansion joint
- Covering-flange
- ( End-cap

## 21. GENERAL MAINTENANCE:

### 1) General points

Any intervention must be carried out **with the line switched off at the mains.**

Maintenance primarily concerns the conductive tracks and the trolleys.

Any damage to the conductive tracks will reduce the operating life of the brushes.

This damage may take different forms:

- Oxidation due to a chemical environment
- Abrasive dust
- Damage due to electrical arcs in the case of a faulty contact following oxidation, heavy soiling or use of worn brushes.

Regular inspection is required to check the wear of the brushes, casters of wheels and the quality of the conductive tracks according to the rate of use, the distance covered, and the chemical environment. *Inspection is required when the distance covered reaches 3,000 km or after one year of use at the most.*

### 2) Monitoring the tracks

The tracks normally become covered with a protective black sheen with the repeated passage of the collector trolleys with Elite. Check the surface condition of the tracks at a junction point between the casings. The surface should be smooth. If the tracks are rough to the touch, run the cleaning trolley. You will find them under the [components](#) section.

**Caution** : the cleaning trolley is not designed to run over long distances, its brushes wear down more rapidly than the conventional brushes.

### 3) Checking the brushes

Switch the line off at the mains, take out the collector.

The replacement of the brushes depends on the line intensity, since the thicker the conductor, the greater the wear reserve.

These limits are etched on the body of the ELITE trolley with 4 to 6 casters:

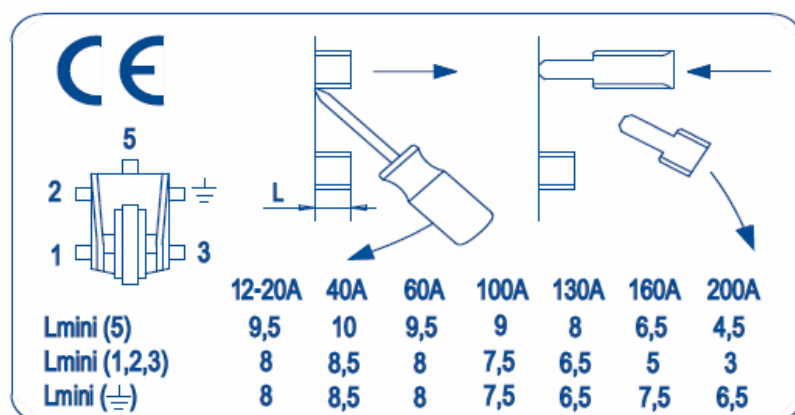

The diagram shows a trolley with 5 casters, labeled with CE, 5, 2, 1, 3, and a ground symbol. It also shows a trolley with 4 casters and a trolley with 6 casters. Below the diagrams is a table of brush limits for different line intensities.

	12-20A	40A	60A	100A	130A	160A	200A
Lmini (5)	9,5	10	9,5	9	8	6,5	4,5
Lmini (1,2,3)	8	8,5	8	7,5	6,5	5	3
Lmini (≡)	8	8,5	8	7,5	6,5	7,5	6,5

### 4) Monitoring of trolleys

Replace MOBILIS Elite trolleys every 10,000 km approximately (trolleys, 4 to 6 casters, or every 3,000 km approximately for trolleys with 2 casters – these values may be reduced according to the operating speed and the driving conditions), or in the event of excessive wear of the driving rings,

Mobilis Elite Technical Data

chains, of the central section of the trolley casing, or of the casters. Ensure the safety pins are present when mounting.

Dust-removal of trolley sides to preserve the insulation performance.

Check particularly the following points:

- Absence of excessive play of caster axle
- Absence of excessive lateral play
- Absence of wear of guiding sides
- Free rotation of casters

#### 5) Maintenance of circuit interruptions and transfer elements

Using insulation controller, check circuit interruption and transfer elements under voltage higher than the rated voltage.

Check absence of wear of transfer elements guiding sides

#### 6) Maintenance elements

Refer to the section "Spare parts" for the following items:

- ⇒ [Replacement connections](#)
- ⇒ [Replacement brushes](#)
- ⇒ [Replacement cleaning brushes](#)
- ⇒ [Cones of transfer elements](#)

## 22. GUARANTEE

Our equipment is guaranteed one year against any material or manufacturing defect recognized by ourselves. As we are not responsible for its installation and operation, our guarantee covers only replacement or repair (at our own choosing) of the part recognized to be defective.

We do not accept responsibility for any defects arising from faulty supervision or maintenance. We also disclaim liability for any production stoppages that may result. Any arbitration shall be held in Strasbourg, even when several defendants are involved.

## Standard straight element

Straight element with built-in conductors and pre-mounted connections, usable up to 55°C ambient temperature.



### Description

Feeds the mobile trolley and ensures the insulation and protection against accidental contact.

### Categorie

Standard

### Avantage n°1

Easy and fast connection, safe assembling

### Avantage n°2

IP 23: Index of protection against access to dangerous parts and rain

## Références et compatibilités

### Références et variantes

The standard straight elements are available with varying lengths of 4m, 3m, 2m, 1m, and special lengths, with or without lips, for high temperature up to +75°C (see 'High temperature (H.T.) straight elements'), without earth marking (see 'Straight elements without earth marking'). For curved elements, see 'Curves'. The intensities indicated are valid for 50Hz, 60Hz and D.C. For 200A version with earth section identical to the phase section, refer to the section of obsolete products.

### Références et variantes

Intensity	12A		20A		40A		60A		100A		130A		160A		200A-TR	
Max Current for 100% duty cycle 35°C / 40°C	12A / 12A		20A / 20A		68A / 64A		85A / 82A		114A / 106A		120A / 109A		152A / 145A		184A / 171A	
Max Current for 80% duty cycle 35°C / 40°C	12A / 12A		20A / 20A		72A / 67A		90A / 86A		117A / 109A		127A / 117A		162A / 155A		210A / 195A	
Section L1, L2, L3, N	stainless steel 16 mm <sup>2</sup>		galvanized steel 16 mm <sup>2</sup>		copper 10mm <sup>2</sup>		copper 16mm <sup>2</sup>		copper 24mm <sup>2</sup>		copper 35mm <sup>2</sup>		copper 48mm <sup>2</sup>		copper 70mm <sup>2</sup>	
Section PE	stainless steel 16 mm <sup>2</sup>		galvanized steel 16 mm <sup>2</sup>		copper 10mm <sup>2</sup>		copper 16mm <sup>2</sup>		copper 24mm <sup>2</sup>		copper 35mm <sup>2</sup>		copper 24mm <sup>2</sup>		copper 35mm <sup>2</sup>	
Number of poles	4	5	4	5	4	5	4	5	4	5	4	5	4	5	4	5
Weight (kg/m)	1,7	1,8	1,7	1,8	1,5	1,6	1,8	1,9	2	2,1	2,4	2,7	2,6	3	3,3	3,9
Length 4m	ME4804	ME5804	ME4204	ME5204	ME4404	ME5404	ME4604	ME5604	ME4104	ME5104	ME4134	ME5134	ME4164	ME5164	ME8284-TR	ME8285-TR
Length 3m	ME4803	ME5803	ME4203	ME5203	ME4403	ME5403	ME4603	ME5603	ME4103	ME5103	ME4133	ME5133	ME4163	ME5163	ME8283-TR	ME8289-TR
Length 2m	ME4802	ME5802	ME4202	ME5202	ME4402	ME5402	ME4602	ME5602	ME4102	ME5102	ME4132	ME5132	ME4162	ME5162	ME8282-TR	ME8286-TR
Length 1m	ME4801	ME5801	ME4201	ME5201	ME4401	ME5401	ME4601	ME5601	ME4101	ME5101	ME4131	ME5131	ME4161	ME5161	ME8281-TR	ME8287-TR
Special length	ME4800	ME5800	ME4200	ME5200	ME4400	ME5400	ME4600	ME5600	ME4100	ME5100	ME4130	ME5130	ME4160	ME5160	ME8280-TR	ME8288-TR

Disponible avec lèvres ?

oui

Disponible en version haute température ?

oui

Disponible en version sans terre ?

oui

## Données techniques

### Données techniques

Element with connection system fitted with built-in self-breaking screws, guaranteeing tightening at optimum torque. 'Floating' conductors fitted to manage the differences in expansion with the PVC line. The protection conductor is identified by a green-yellow band over the entire length of the element.

<b>Encombrement L x H x Z</b>	64 x 90 x		
<b>Poids</b>	According to reference		
<b>Tension d'emploi</b>	750V	<b>Température d'utilisation</b>	-30°C to +55°C
<b>Calibre</b>	12A, 20A, 40A, 60A, 100A, 130A, 160A, 200A		
<b>Matière</b>	Self-extinguishing PVC light grey		

### Fichier 3D à télécharger

[http://catalogue.fels.fr/medias/produits/Gaine\\_2010\\_06.7z](http://catalogue.fels.fr/medias/produits/Gaine_2010_06.7z)

### Fichier 2D d'implantation face

[http://catalogue.fels.fr/medias/produits/Gaine\\_face\\_DXF.7z](http://catalogue.fels.fr/medias/produits/Gaine_face_DXF.7z)

### Fichier 2D d'implantation profil

[http://catalogue.fels.fr/medias/produits/Gaine\\_profile\\_DXF.7z](http://catalogue.fels.fr/medias/produits/Gaine_profile_DXF.7z)

### Fichier 2D d'implantation dessus

[http://catalogue.fels.fr/medias/produits/Gaine\\_top\\_DXF.7z](http://catalogue.fels.fr/medias/produits/Gaine_top_DXF.7z)

## Montage

### Outils nécessaires au montage

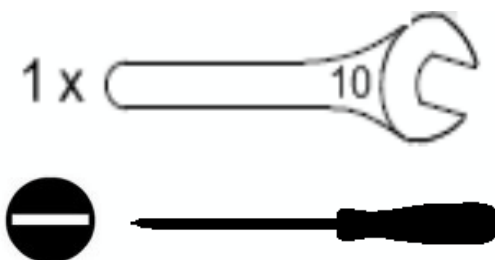

### Outils nécessaires au démontage

### Règle d'installation 1

Elements to be clipped in sliding hangers, end to end connection of elements by tightening the connections. For lengths above 140 meters, or when curves, transfer elements, or rigid power cables are fitted, please refer to the section 'Expansion joints' to determine if an expansion joint is required. Position the elements at a distance from support large enough to provide access to the connections and to position the accessories (covering flange, feed box): minimum recommended clearance of 65mm.

### Règle de montage 1

1. Insert the lines in the sliding hangers, 2. Connect the lines



## Règle de montage 2

## Règle de montage 3

### 6 Connexion des conducteurs

Connection of conductors

Verbindung der Leiter

- 20A → 130A  
PE 160A / PE 200A TR :

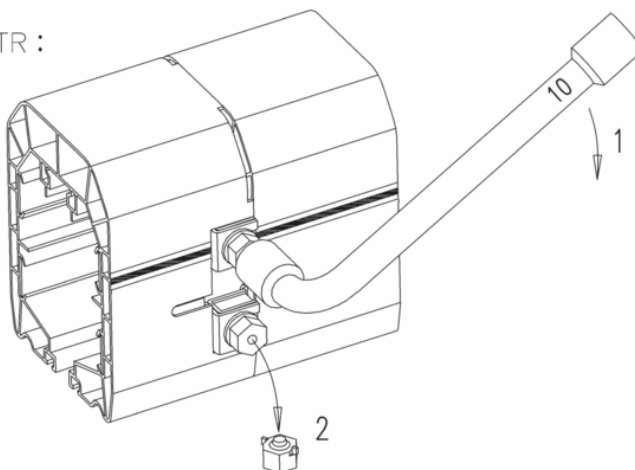
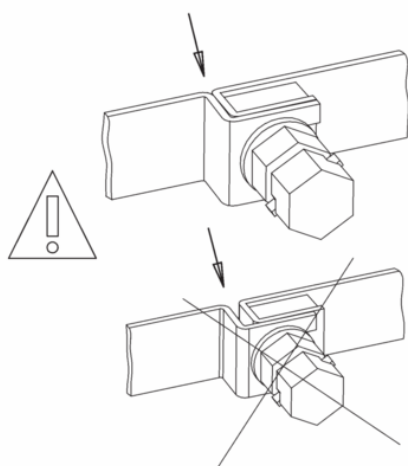

**Serrer jusqu'à rupture des têtes de vis**

*Tighten until the screw heads break*

Anziehen, bis die Schraubenköpfe brechen



**Connecter les conducteurs 40A avec précaution**

*Connect the 40A-conductors cautiously*

40A-Leiter vorsichtig verbinden

- 160A → 200A :

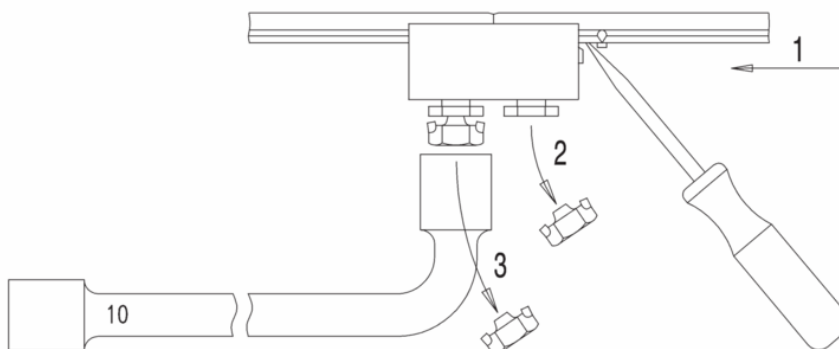
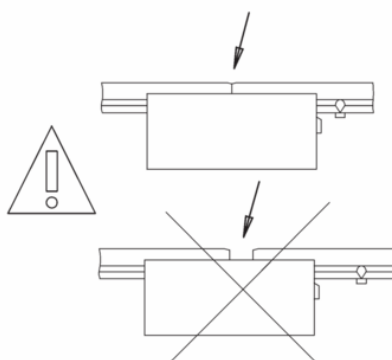

## Maintenance

See the rules of maintenance of the lines

## High temperature straight element

Straight element with built-in conductors and pre-mounted connections, usable up to 75°C ambient temperature.



### Description

Feeds the mobile trolley and ensures the insulation and protection against accidental contact.

### Categorie

High Temperature

### Avantage n°1

Can be used up to +75°C

### Avantage n°2

IP 23: Index of protection against access to dangerous parts and rain

## Références et compatibilités

### Références et variantes

The high temperature straight elements are available with varying lengths of 4m, 3m, 2m, 1m, and special lengths. Not fitted with protection lips, no version without earth marking. For curved elements, see 'Curves'. The intensities indicated are valid for 50Hz, 60Hz and D.C.

### Références et variantes

Intensity	12A-HT		20A-HT		40A-HT		60A-HT		100A-HT		130A-HT		160A-HT		200A-HT TR	
Max Current for 100% duty cycle 35°C / 40°C	12A / 12A		20A / 20A		81A / 78A		101A / 99A		136A / 129A		142A / 136A		171A / 167A		221A / 211A	
Max Current for 80% duty cycle 35°C / 40°C	12A / 12A		20A / 20A		85A / 81A		108A / 105A		140A / 133A		150A / 143A		181A / 178A		254A / 241	
Max Current for 100% duty cycle 70°C	12A		20A		50A		60A		81A		85A		103A		120A	
Section L1, L2, L3, N	stainless steel 16mm <sup>2</sup>		galvanized steel 16 mm <sup>2</sup>		copper 10mm <sup>2</sup>		copper 16mm <sup>2</sup>		copper 24mm <sup>2</sup>		copper 35mm <sup>2</sup>		copper 48mm <sup>2</sup>		copper 70mm <sup>2</sup>	
Section PE	stainless steel 16mm <sup>2</sup>		galvanized steel 16 mm <sup>2</sup>		copper 10mm <sup>2</sup>		copper 16mm <sup>2</sup>		copper 24mm <sup>2</sup>		copper 35mm <sup>2</sup>		copper 24mm <sup>2</sup>		copper 35mm <sup>2</sup>	
Number of poles	4	5	4	5	4	5	4	5	4	5	4	5	4	5	4	5
Weight (kg/m)	1,7	1,8	1,7	1,8	1,5	1,6	1,8	1,9	2	2,1	2,4	2,7	2,6	3	3,3	3,9
Length 4m	ME4804-HT	ME5804-HT	ME4204-HT	ME5204-HT	ME4404-HT	ME5404-HT	ME4604-HT	ME5604-HT	ME4104-HT	ME5104-HT	ME4134-HT	ME5134-HT	ME4164-HT	ME5164-HT	ME8284-HT TR	ME8285-HT TR
Length 3m	ME4803-HT	ME5803-HT	ME4203-HT	ME5203-HT	ME4403-HT	ME5403-HT	ME4603-HT	ME5603-HT	ME4103-HT	ME5103-HT	ME4133-HT	ME5133-HT	ME4163-HT	ME5163-HT	ME8283-HT TR	ME8289-HT TR
Length 2m	ME4802-HT	ME5802-HT	ME4202-HT	ME5202-HT	ME4402-HT	ME5402-HT	ME4602-HT	ME5602-HT	ME4102-HT	ME5102-HT	ME4132-HT	ME5132-HT	ME4162-HT	ME5162-HT	ME8282-HT TR	ME8286-HT TR
Length 1m	ME4801-HT	ME5801-HT	ME4201-HT	ME5201-HT	ME4401-HT	ME5401-HT	ME4601-HT	ME5601-HT	ME4101-HT	ME5101-HT	ME4131-HT	ME5131-HT	ME4161-HT	ME5161-HT	ME8281-HT TR	ME8287-HT TR
Special length	ME4800-HT	ME5800-HT	ME4200-HT	ME5200-HT	ME4400-HT	ME5400-HT	ME4600-HT	ME5600-HT	ME4100-HT	ME5100-HT	ME4130-HT	ME5130-HT	ME4160-HT	ME5160-HT	ME8280-HT TR	ME8288-HT TR

Disponible avec lèvres ?

non

Disponible en version sans terre ?

non

Disponible en version courbe ?

oui

---

# Données techniques

## Données techniques

Element with connection system fitted with built-in self-breaking screws, guaranteeing tightening at optimum torque. 'Floating' conductors fitted to manage the differences in expansion with the PVC line. The protection conductor is identified by a green-yellow band over the entire length of the element. Caution: H.T. line cannot be fitted with dust-protecting lips, since the lip seal material is not appropriate for temperatures above 55°C.

<b>Encombrement L x H x Z</b>	64 x 90 x		
<b>Poids</b>	According to reference		
<b>Tension d'emploi</b>	440VAC	<b>Température d'utilisation</b>	-30°C to +75°C
<b>Calibre</b>	12A, 20A, 40A, 60A, 100A, 130A, 160A, 200A		
<b>Matière</b>	Self-extinguishing PVC white		

---

# Montage

## Outils nécessaires au montage

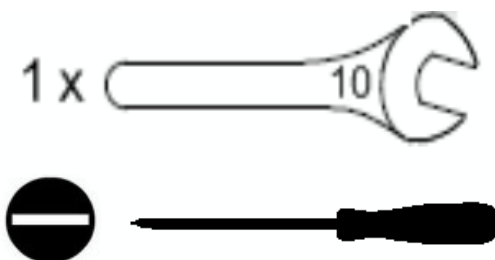

## Outils nécessaires au démontage

### Règle d'installation 1

Elements to be clipped in sliding hangers, end to end connection of elements by tightening the connections. For lengths above 140 meters, or when curves, transfer elements, or rigid power cables are fitted, please refer to the section 'Expansion joints' to determine if an expansion joint is required. Position the elements at a distance from the support large enough to provide access to the connections and to position the accessories (covering flange, feed box): minimum recommended clearance of 65mm.

### Règle de montage 1

1. Insert the lines in the sliding hangers, 2. Connect the lines

### Règle de montage 2

## 6 Connexion des conducteurs

Connection of conductors

Verbindung der Leiter

- 20A → 130A  
PE 160A / PE 200A TR :

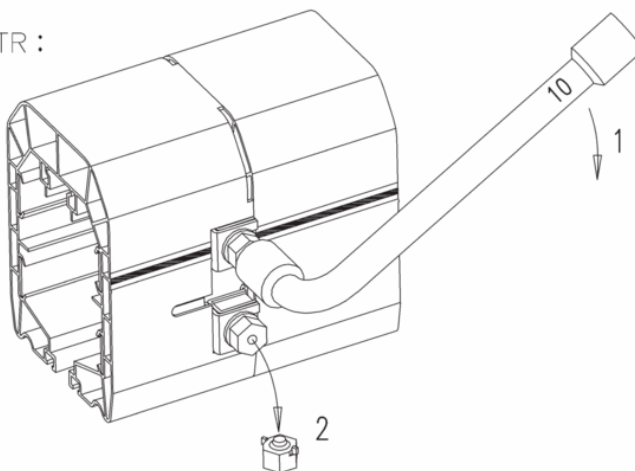
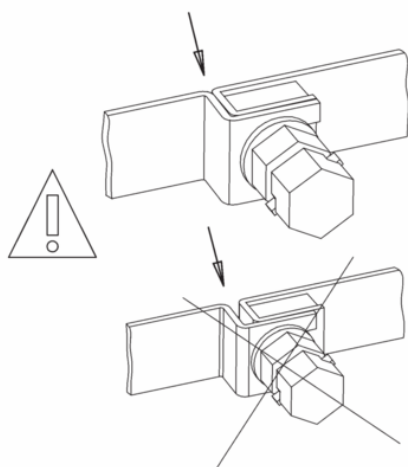

**Serrer jusqu'à rupture des têtes de vis**  
*Tighten until the screw heads break*  
Anziehen, bis die Schraubenköpfe brechen



**Connecter les conducteurs 40A avec précaution**  
*Connect the 40A-conductors cautiously*  
40A-Leiter vorsichtig verbinden

- 160A → 200A :

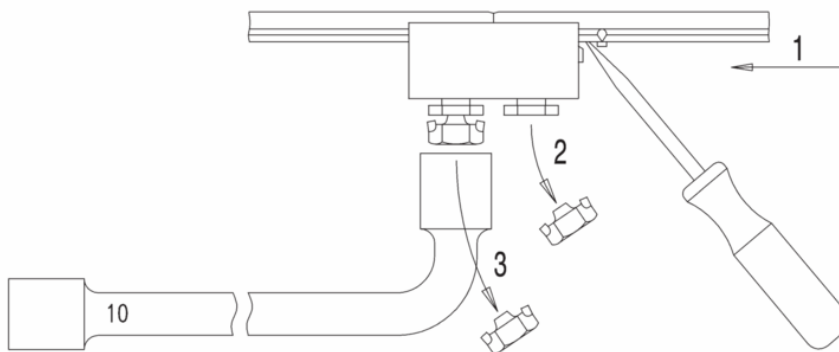
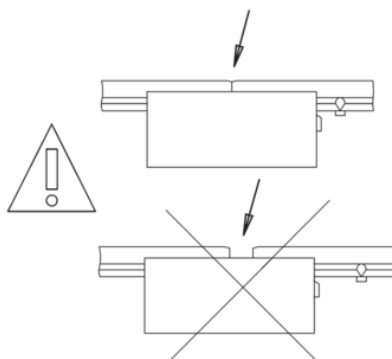

## Maintenance

See the rules of maintenance of the lines

## Straight element without earth marking

Straight element without earth marking, with built-in conductors and pre-mounted connections, usable up to 55°C.

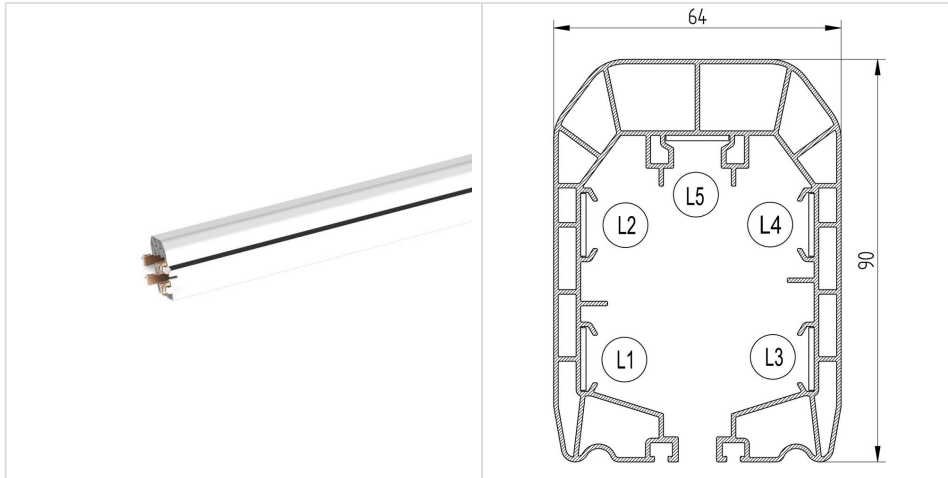

### Description

Feeds the mobile trolley and ensures the insulation and protection against accidental contact.

### Categorie

Without PE

### Avantage n°1

All conductors may be used as active conductors

### Avantage n°2

IP 23: Index of protection against access to dangerous parts and rain

## Références et compatibilités

### Références et variantes

The straight elements with no marking of the protection conductor are available with varying lengths of 4m, 3m, 2m, 1m, and special lengths, with/and without protection lips. The references are identical to the standard line elements, but with '- B' quoted after the reference, for example ME4404-B. Caution: the feedings and trolleys are specific: refer to the related sections. For ordering a version with lips, use a new reference replacing - B by - LVB: for example ME4404-B becomes ME4404-LVB in version with lips, and without earth marking. The intensities indicated are valid for 50Hz, 60Hz and D.C.

### Références et variantes

Intensity	12A		20A		40A		60A		100A		130A		160A		200A	
Max current for 100% duty cycle 35°C / 40°C	12A / 12A		20A / 20A		61A / 58A		78A / 74A		103A / 95A		108A / 98A		137A / 130A		162A / 154A	
Max current for 80% duty cycle 35°C / 40°C	12A / 12A		20A / 20A		65A / 60A		81A / 77A		105A / 98A		114A / 105A		146A / 140A		189A / 174A	
Section L1, L2, L3, L4, L5	stainless steel 16 mm <sup>2</sup>		galvanized steel 16 mm <sup>2</sup>		copper 10mm <sup>2</sup>		copper 16mm <sup>2</sup>		copper 24mm <sup>2</sup>		copper 35mm <sup>2</sup>		copper 48mm <sup>2</sup>		copper 70mm <sup>2</sup>	
Number of poles	4	5	4	5	4	5	4	5	4	5	4	5	4	5	4	5
Weight (kg/m)	1,7	1,8	1,7	1,8	1,5	1,6	1,8	1,9	2	2,1	2,4	2,7	2,7	3,1	3,6	4,2
Length 4m	ME4804-B	ME5804-B	ME4204-B	ME5204-B	ME4404-B	ME5404-B	ME4604-B	ME5604-B	ME4104-B	ME5104-B	ME4134-B	ME5134-B	ME4164-B	ME5164-B	ME8284-B	ME8285-B
Length 3m	ME4803-B	ME5803-B	ME4203-B	ME5203-B	ME4403-B	ME5403-B	ME4603-B	ME5603-B	ME4103-B	ME5103-B	ME4133-B	ME5133-B	ME4163-B	ME5163-B	ME8283-B	ME8289-B
Length 2m	ME4802-B	ME5802-B	ME4202-B	ME5202-B	ME4402-B	ME5402-B	ME4602-B	ME5602-B	ME4102-B	ME5102-B	ME4132-B	ME5132-B	ME4162-B	ME5162-B	ME8282-B	ME8286-B
Length 1m	ME4801-B	ME5801-B	ME4201-B	ME5201-B	ME4401-B	ME5401-B	ME4601-B	ME5601-B	ME4101-B	ME5101-B	ME4131-B	ME5131-B	ME4161-B	ME5161-B	ME8281-B	ME8287-B
Special length	ME4800-B	ME5800-B	ME4200-B	ME5200-B	ME4400-B	ME5400-B	ME4600-B	ME5600-B	ME4100-B	ME5100-B	ME4130-B	ME5130-B	ME4160-B	ME5160-B	ME8280-B	ME8288-B

Disponible avec lèvres ?

oui

Disponible en version haute température ?

non

Disponible en version courbe ?

oui

---

## Données techniques

### Données techniques

PVC Line with connection system fitted with self-breaking screws, guaranteeing a tightening of the connections to the ideal torque. All conductors of the elements without earth marking can be active conductors and supply power or signal when a protection conductor is not required. The element is identified by a black band over the entire length.

<b>Encombrement L x H x Z</b>	64 x 90 x		
<b>Poids</b>	According to reference		
<b>Tension d'emploi</b>	750V	<b>Température d'utilisation</b>	-30°C to +55°C
<b>Calibre</b>	12A, 20A, 40A, 60A, 100A, 130A, 160A, 200A		
<b>Matière</b>	Self-extinguishing PVC light grey		

---

## Montage

### Outils nécessaires au montage

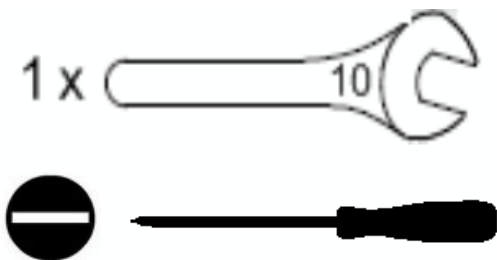

### Outils nécessaires au démontage

### Règle d'installation 1

Elements to be clipped in sliding hangers, end to end connection of elements by tightening the connections. For lengths above 140 meters, or when curves, transfer elements, or rigid power cables are fitted, please refer to the section 'Expansion joints' to determine if an expansion joint is required. Position the elements at a distance from the support large enough to provide access to the connections and to position the accessories (covering flange, feed box): minimum recommended clearance of 65mm. It is the responsibility of the fitter to precisely identify the D.C. current poles according to the requirements for the circuit.

### Règle de montage 1

1. Insert the lines in the sliding hangers, 2. Connect the lines

Règle de montage 2

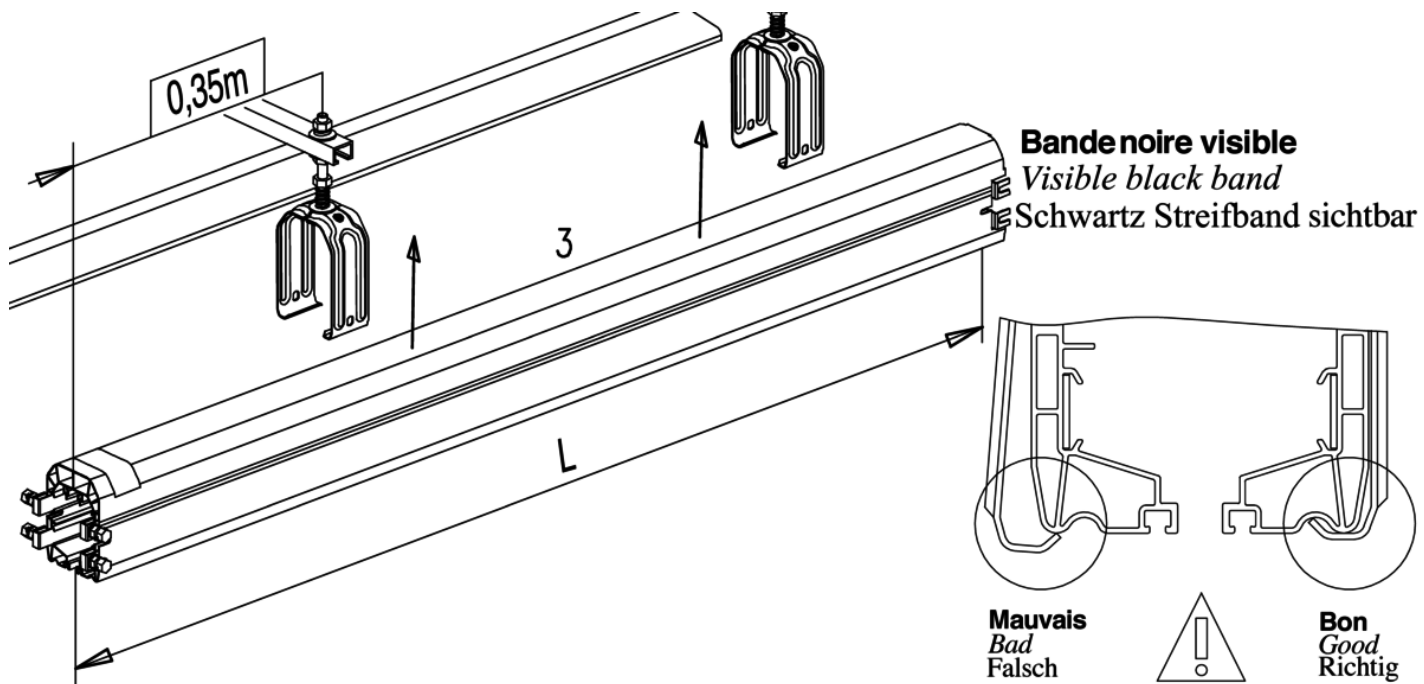

## 6 Connexion des conducteurs

Connection of conductors

Verbindung der Leiter

• 12A → 130A

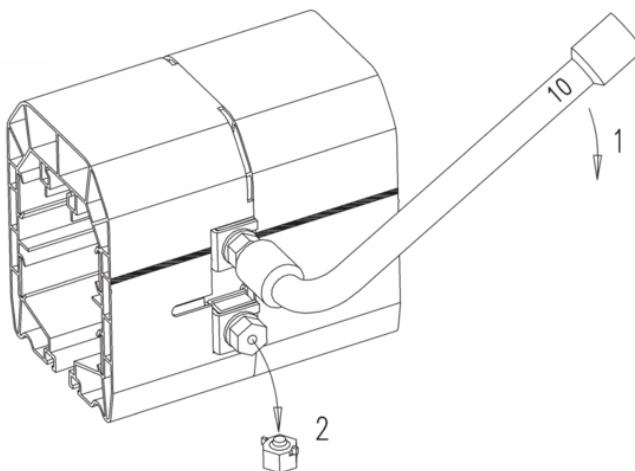
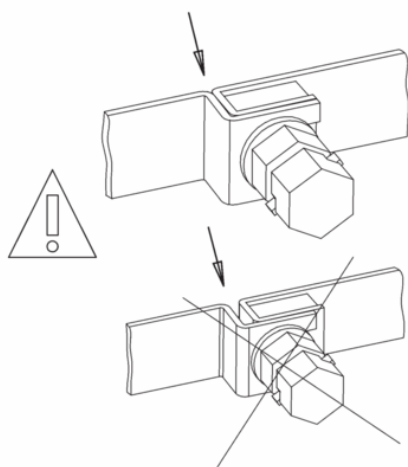

**Serrer jusqu'à rupture des têtes de vis**

*Tighten until the screw heads break*

Anziehen, bis die Schraubenköpfe brechen



**Connecter les conducteurs 40A avec précaution**

*Connect the 40A-conductors cautiously*

40A-Leiter vorsichtig verbinden

• 160A → 200A :

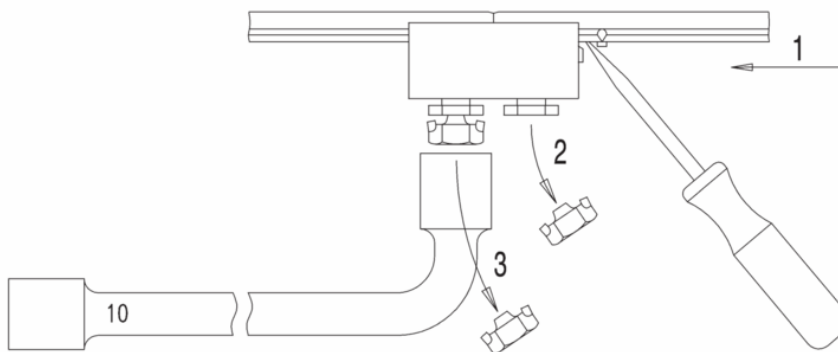
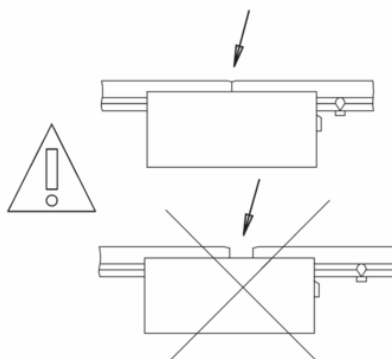

## Maintenance

See the rules of maintenance of the lines



## Straight element with protection lips

Straight element with built-in conductors and pre-mounted connections, dust protection lips pre-mounted in factory, usable up to 55°C ambient temperature.

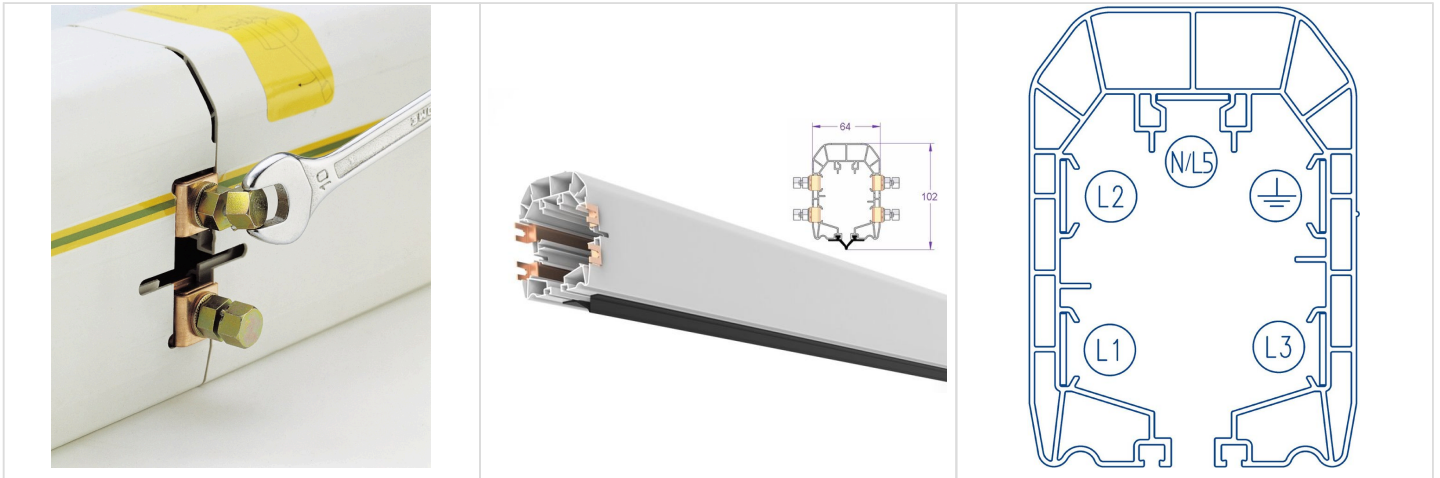

### Description

Feeds the mobile trolley and ensures the insulation and protection against accidental contact and dust.

### Categorie

With lips

### Avantage n°1

Protection from dust

### Avantage n°2

IP 23: Index of protection against the access to the dangerous parts and the rain

## Références et compatibilités

### Références et variantes

The straight elements with lips are available in versions with lengths of 4m, 3m, 2m, 1m and special lengths, without earth marking (see 'Straight elements without earth marking'), for maximum ambient temperature of 55°C. For curved element, see 'Curves'. The intensities indicated are valid for 50Hz, 60Hz and D.C.

### Références et variantes

Intensity	12A		20A		40A		60A		100A		130A		160A		200A-TR	
Max current for 100% duty cycle 35°C / 40°C	12A / 12A		20A / 20A		68A / 64A		85A / 82A		114A / 106A		120A / 109A		152A / 145A		184A / 171A	
Max current for 80% duty cycle 35°C / 40°C	12A / 12A		20A / 20A		72A / 67A		90A / 86A		117A / 109A		127A / 117A		162A / 155A		210A / 195A	
Section L1, L2, L3, N	stainless steel 16 mm <sup>2</sup>		galvanized steel 16 mm <sup>2</sup>		copper 10mm <sup>2</sup>		copper 16mm <sup>2</sup>		copper 24mm <sup>2</sup>		copper 35mm <sup>2</sup>		copper 48mm <sup>2</sup>		copper 70mm <sup>2</sup>	
Section PE	stainless steel 16 mm <sup>2</sup>		galvanized steel 16 mm <sup>2</sup>		copper 10mm <sup>2</sup>		copper 16mm <sup>2</sup>		copper 24mm <sup>2</sup>		copper 35mm <sup>2</sup>		copper 48mm <sup>2</sup>		copper 70mm <sup>2</sup>	
Number of poles	4	5	4	5	4	5	4	5	4	5	4	5	4	5	4	5
Weight (kg/m)	1,8	1,9	1,8	1,9	1,6	1,7	1,9	2	2,1	2,2	2,5	2,8	2,7	3,1	3,4	4
Length 4m	ME4804-LV	ME5804-LV	ME4204-LV	ME5204-LV	ME4404-LV	ME5404-LV	ME4604-LV	ME5604-LV	ME4104-LV	ME5104-LV	ME4134-LV	ME5134-LV	ME4164-LV	ME5164-LV	ME8284-LV TR	ME8285-LV TR
Length 3m	ME4803-LV	ME5803-LV	ME4203-LV	ME5203-LV	ME4403-LV	ME5403-LV	ME4603-LV	ME5603-LV	ME4103-LV	ME5103-LV	ME4133-LV	ME5133-LV	ME4163-LV	ME5163-LV	ME8283-LV TR	ME8289-LV TR
Length 2m	ME4802-LV	ME5802-LV	ME4202-LV	ME5202-LV	ME4402-LV	ME5402-LV	ME4602-LV	ME5602-LV	ME4102-LV	ME5102-LV	ME4132-LV	ME5132-LV	ME4162-LV	ME5162-LV	ME8282-LV TR	ME8286-LV TR
Length 1m	ME4801-LV	ME5801-LV	ME4201-LV	ME5201-LV	ME4401-LV	ME5401-LV	ME4601-LV	ME5601-LV	ME4101-LV	ME5101-LV	ME4131-LV	ME5131-LV	ME4161-LV	ME5161-LV	ME8281-LV TR	ME8287-LV TR
Special length	ME4800-LV	ME5800-LV	ME4200-LV	ME5200-LV	ME4400-LV	ME5400-LV	ME4600-LV	ME5600-LV	ME4100-LV	ME5100-LV	ME4130-LV	ME5130-LV	ME4160-LV	ME5160-LV	ME8280-LV TR	ME8288-LV TR

Disponible en version haute température ? non

Disponible en version sans terre ?

oui

Disponible en version courbe ?

oui

# Données techniques

## Données techniques

PVC line with connection system fitted with built-in self-breaking screws, guaranteeing tightening at optimum torque. Self-extinguishing elastomer lips. Designed to limit ingress of dust in the line. Index of protection: IP23. The sections with lips must be fitted with covering flanges or feed boxes appropriate to the lips. Caution: Use only simple single trolleys and carriers. The dust-protecting lips are not appropriate for temperatures above 55°C. The protection conductor is identified by a green-yellow band over the entire length of the element. Special elements are also available with dust-protecting devices.

<b>Encombrement L x H x Z</b>	64 x 102 x		
<b>Poids</b>	According to reference		
<b>Tension d'emploi</b>	750V	<b>Température d'utilisation</b>	-20°C to +55°C
<b>Calibre</b>	12A, 20A, 40A, 60A, 100A, 130A, 160A, 200A		
<b>Matière</b>	Self-extinguishing PVC light grey, black lips		

## Montage

### Outils nécessaires au montage

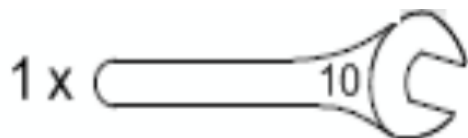

### Outils nécessaires au démontage

### Règle d'installation 1

Elements to be clipped in sliding hangers, end to end connection of elements by tightening the connections. For lengths above 140 meters, or when curves, transfer elements, or rigid power cables are fitted, please refer to the section 'Expansion joints' to determine if an expansion joint is required. Position the elements at a distance from the support large enough to provide access to the connections and to position the accessories (covering flange, feed box): minimum recommended clearance of 65mm.

### Règle de montage 1

1. Insert the lines in the sliding hangers, 2. Connect the lines

### Règle de montage 2

**6 Connexion des conducteurs**

*Connection of conductors*

*Verbindung der Leiter*

- 20A → 130A  
PE 160A / PE 200A TR :

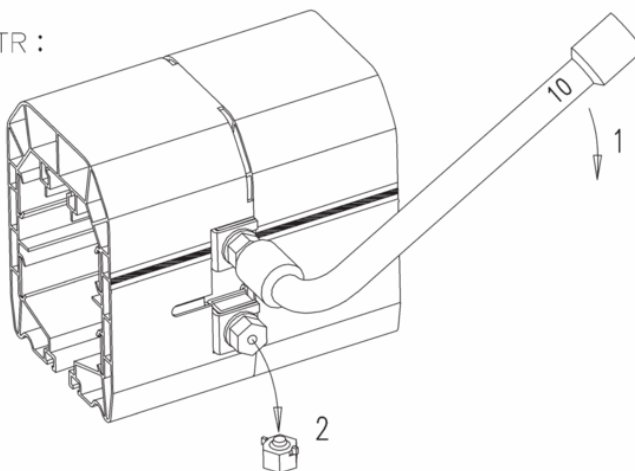
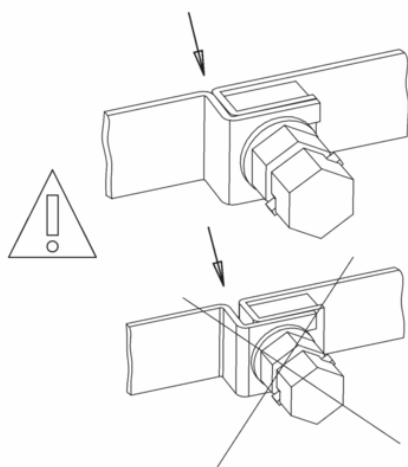

**Serrer jusqu'à rupture des têtes de vis**  
*Tighten until the screw heads break*  
Anziehen, bis die Schraubenköpfe brechen



**Connecter les conducteurs 40A avec précaution**  
*Connect the 40A-conductors cautiously*  
40A-Leiter vorsichtig verbinden

- 160A → 200A :

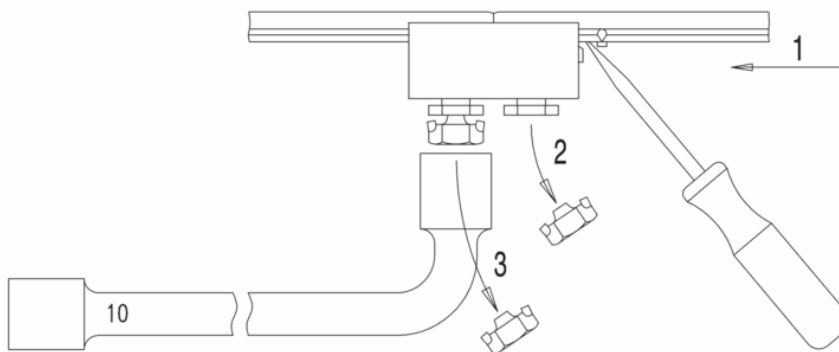
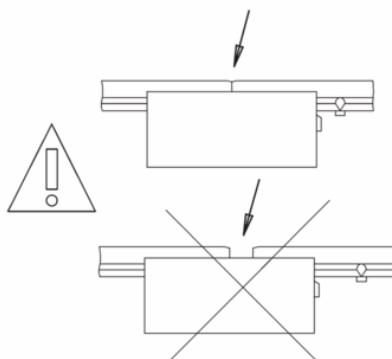

**Maintenance**

Repeat the application of silicone grease between the lips if excessive adhesion is observed. The assembling of the lips can be made in the workshop using specific tools, please enquire.

## Covering flange

Accessory for electrical insulation of the junctions.

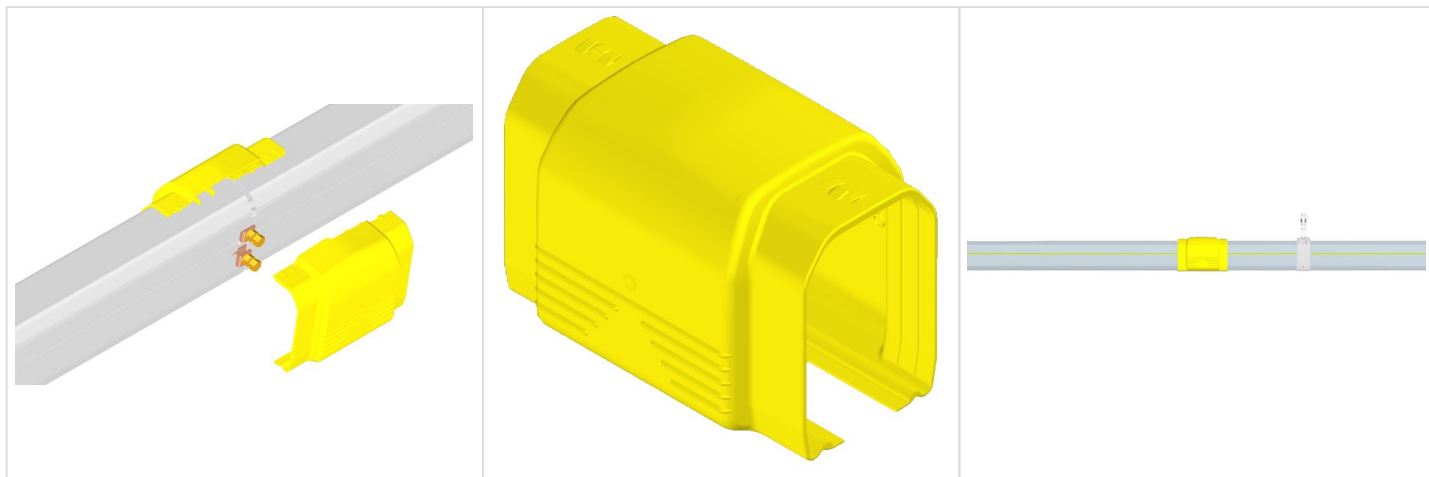

### Description

The covering flange is used to protect the operator against direct contact with the connections. It also ensures the protection of the junctions against hard conditions of the environment. Assembling only possible if the heads of the connection screws have been correctly broken.

### Categorie

Standard

### Avantage n°1

Non-forgettable connection system

### Avantage n°2

Clipped-on assembling, no tools required

## Références et compatibilités

### Références et variantes

Ref. ME2000, This reference is for the junctions between standard straight elements, and for high temperature. Alternative versions: ME2000-CO for curves, ME2000-LV for lines with lips and MO2000-COLV for curves with lips.

### Disponible avec lèvres ?

yes, ME2000-LV

### Disponible en version courbe ?

ME2000-CO

## Données techniques

## Encombrement

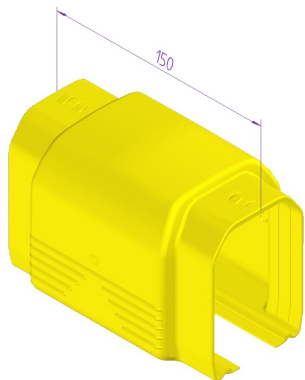

**Encombrement L x H x Z**

94 x 104 x 150

**Poids**

0,1 kg

**Tension d'emploi**

750V

**Température d'utilisation**

-30°C to +75°C

**Calibre**

12A, 20A, 40A, 60A, 100A, 130A, 160A, 200A

**Matière**

Self-extinguishing thermoplastic

**Fichier 3D à télécharger**

[http://catalogue.fels.fr/medias/produits/Couvre\\_joint\\_2010\\_06.7z](http://catalogue.fels.fr/medias/produits/Couvre_joint_2010_06.7z)

---

## Montage

**Outils nécessaires au montage**



**Outils nécessaires au démontage**

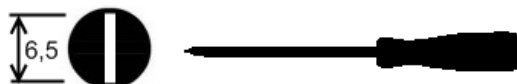

**Règle d'installation 1**

Provide one element at each junction, outside feeding points. Choose the version for curves (ME2000-CO or ME2000-COLV), between curves but also between curve and straight element.

**Règle d'installation 2**

1. Connecter les deux gaines 2. Fermer le couvre-joint sur la connexion

**Règle de montage 1**

1. Connect the two lines 2. Close the covering flange on the connection

**7** **Couvre joint**  
*Covering flange*  
Verbindungsabdeckung

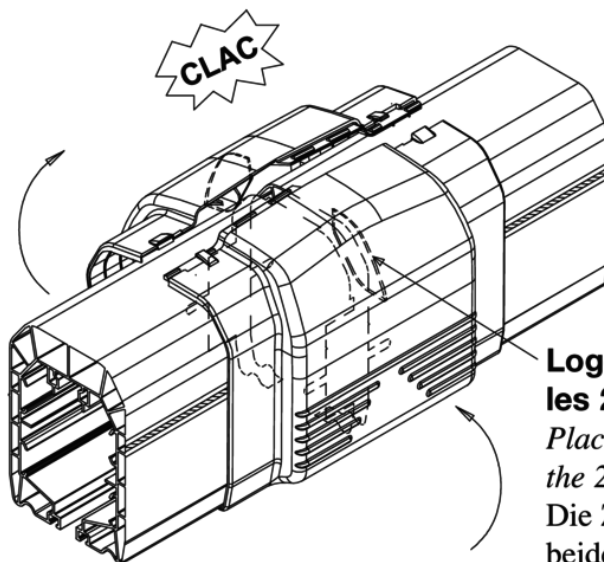
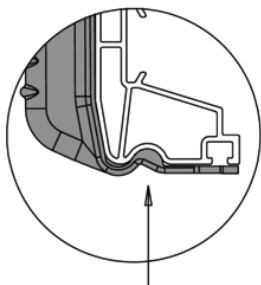

**Loger la nervure entre les 2 gaines**  
*Place the guide-marrk between the 2 elements*  
Die Zentrierrippe zwischen beiden Elementen anbringen

**Maintenance**

This element does not require any special maintenance.

## End-cap

Provides the insulation of live elements at the ends of the line.



### Description

The end-cap must be placed at each end of the line to ensure operator protection. Its use is required for CE conformance.

### Categorie

Standard

### Avantage n°1

Clip-on assembling, no tools needed

### Avantage n°2

IP23 Protection

---

## Références et compatibilités

### Références et variantes

ME2400

### Disponible avec lèvres ?

compatible

### Disponible en version haute température ?

compatible

### Disponible en version sans terre ?

compatible

### Disponible en version courbe ?

compatible

---

## Données techniques

### Données techniques

Area with no access to the trolley: 35mm. Extra Length at end of line: 96mm

### Encombrement L x H x Z

94 x 109 x 152

### Poids

0,2 kg

### Tension d'emploi

750V

### Température d'utilisation

-30°C to +75°C

### Calibre

12A, 20A, 40A, 60A, 100A, 130A, 160A, 200A

### Matière

Self-extinguishing thermoplastic

# Montage

## Outils nécessaires au montage



## Outils nécessaires au démontage



### Règle d'installation 1

To be positioned end of line. Provide enough space so as not to impede line expansion (minimum of 6cm for 50metres, minimum of 2.5cm for 100metres).

### Règle d'installation 2

Au préalable, enlever les vis de connexion présentes sur le rail, 1. ouvrir le capot de fermeture, 2 Insérer la pièce en équerre, 3. serrer la vis, 4. Fermer le capot sur la gaine en faisant attention de positionner les rainures l'une dans l'autre.

### Règle de montage 1

Before hand, remove the connection screws fitted to the rail, 1. Open the end-cap, 2 Insert the part with straight angles, 3. Tighten the screw, 4. Close the cap on the line making sure to place the grooves on one another.

### Règle de montage 2

## 11 Capot de fermeture

End-cap

Endkappe

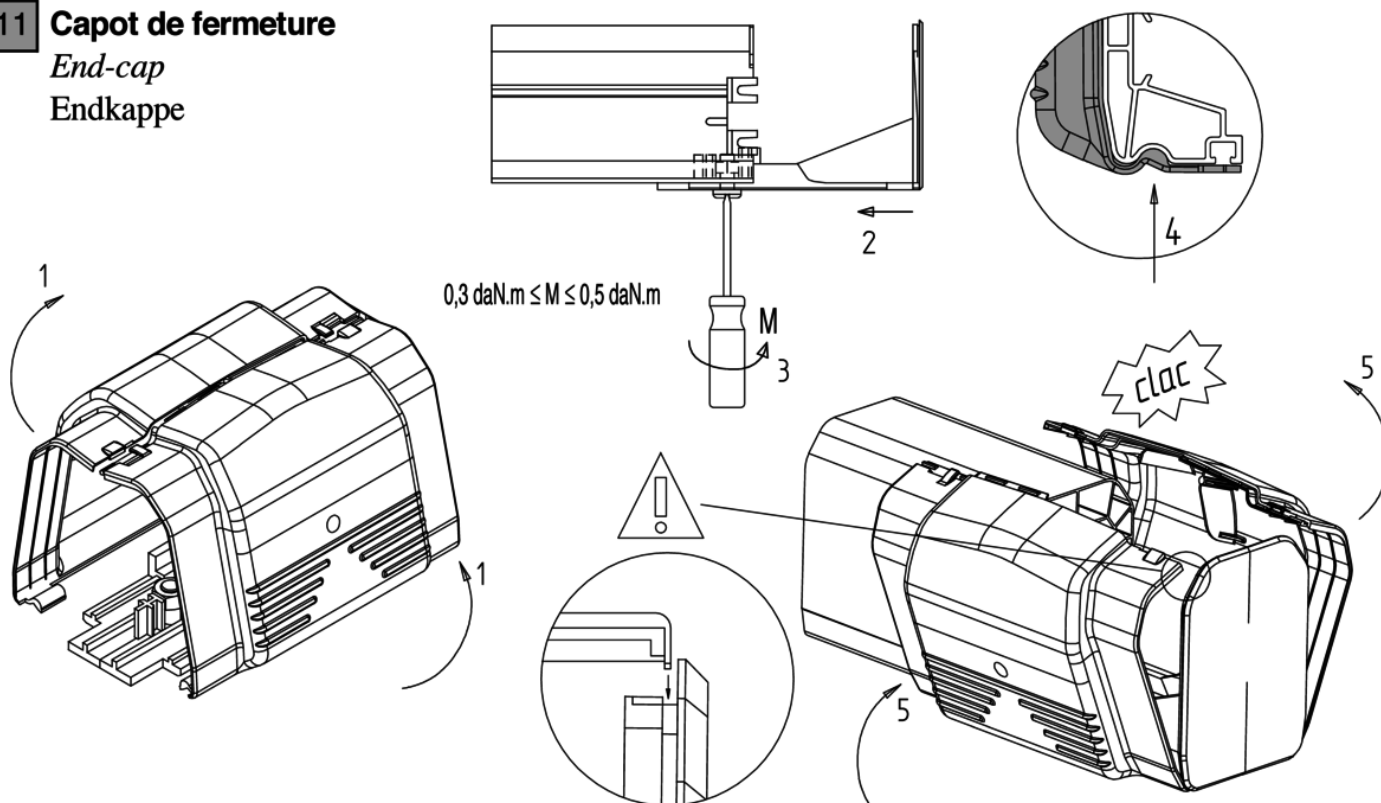

## Maintenance

This element does not require any special maintenance.



## Sliding hanger

Supports the line and allows expansion, self-aligning with the line on assembly.



### Description

The sliding hanger is used to support the line and allow its expansion. The line is inserted by simple insertion upwards. The suspension is fixed to the bracket by nuts to provide precision adjustment of alignment in height.

### Categorie

Standard

### Avantage n°1

Self-alignment system

### Avantage n°2

Easy assembling by screw and simple clip-on of the line

## Références et compatibilités

### Références et variantes

ME1510: sliding hanger fully pre-mounted, fits brackets and line elements of Mobilis Elite line. For suspension with anchoring, refer to 'Fixed hangers'.

## Données techniques

### Données techniques

With screw M8

## Encombrement

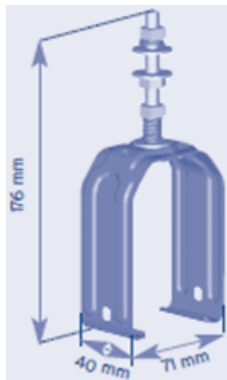

**Encombrement L x H x Z**

71 x 176 x 40

**Poids**

0,1 kg

**Température d'utilisation**

-30°C to +75°C

**Matière**

zinc coated steel

**Fichier 3D à télécharger**

[http://catalogue.fels.fr/medias/produits/Suspension\\_coulissante\\_2010\\_06.7z](http://catalogue.fels.fr/medias/produits/Suspension_coulissante_2010_06.7z)

---

## Montage

**Outils nécessaires au montage**

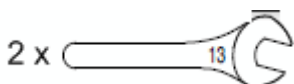

**Outils nécessaires au démontage**

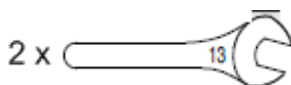

**Règle de montage 1**

Simply clip-on the line between the sides of the sliding hanger. Requires two wrenches No. 13 for assembling on the support. Position the sliding hanger 350mm from the end, then every 2m for 2 sliding hangers per line and every 1.33m for 3 sliding hangers per line.

**Règle de montage 2**

### Règle de montage 3

## 3 Elément de gaine *Line element* Leitungselement

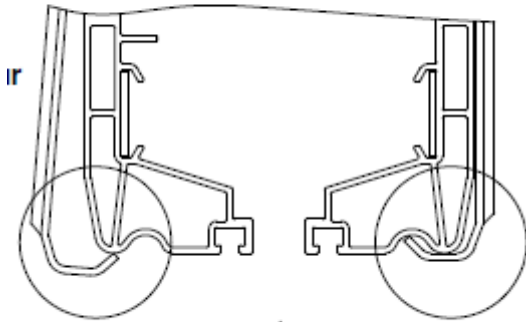

**Mauvais**  
*Bad*  
Falsch



**Bon**  
*Good*  
Richtig

### Maintenance

Preventive maintenance of external or dusty installations: check that the lines slide freely.

## Fixed hanger

Fixes the position of the line and special curved elements and transfer elements.



### Description

The fixed hanger is built on the basis of the sliding hanger. It is entirely pre-mounted and equipped with 2 compression screws immobilising the profile of the line elements.

### Categorie

Standard

### Avantage n°1

Fitted with red discs of visual location

### Avantage n°2

Self-alignment system

---

## Références et compatibilités

### Références et variantes

ME1500

---

## Données techniques

### Données techniques

M8 screw, delivered with 2 built-in anchoring screws and red locating discs

## Encombrement

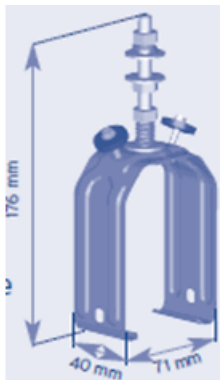

**Encombrement L x H x Z**

71 x 176 x 40

**Poids**

0,1 kg

**Température d'utilisation**

-30°C to +75°C

**Matière**

Zinc coated steel

## Montage

### Outils nécessaires au montage

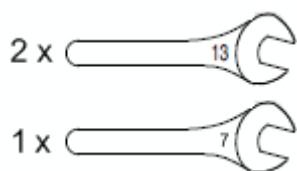

### Outils nécessaires au démontage

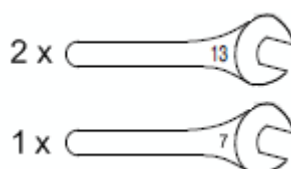

### Règle d'installation 1

The fixed hangers are always placed on a same element of the line. 2 items on the straight elements or the transfer elements, 2 or 3 items on the curves according to the expanded length. Place the fixed hangers midway in the line between 2 expansion joints (lines with transfer elements and/or curves: see special rules in these sections).

### Règle de montage 1

Clip-on the elements of the line, place them longitudinally: tighten fully the 2 compression screws.

## Règle de montage 2

### 5 Point d'ancrage

Fixed hanger  
Festaufhängung



d'abord / first / zuerst

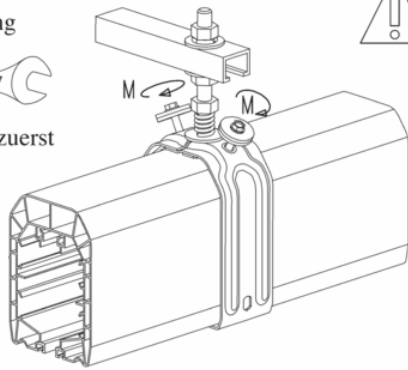

**Position : voir**

Position : see  
Positionierung : siehe

$0,2 \text{ daN.m} < M < 0,3 \text{ daN.m}$

### Disposition des éléments de ligne

Configuration of the different safety conductor system's elements  
Anordnung der einzelnen Schleifleitungsbauteile

### Ligne sans joint de dilatation sauf cas (1) /

Safety conductor system without expansion compensating element except case (1) /  
Schleifleitung ohne Dehnungsteilstück ausgenommen Fall (1)

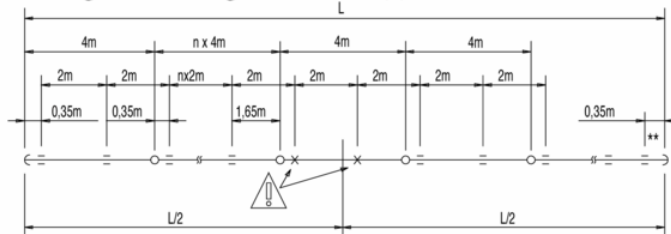

**Ligne avec joint de dilatation / Safety conductor system with expansion compensating element /**  
Schleifleitung mit Dehnungsteilstück

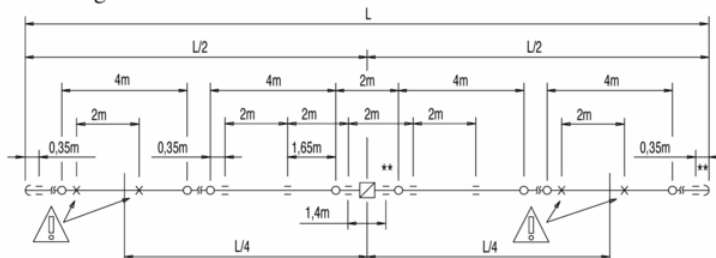

### Legende :

Key :

Symbol :

- × Point d'ancrage / Fix point suspension / Festpunktaufhängung
- = Suspension coulissante / Sliding suspension / Gleitauflängung
- Couvre joint / Joint cover / Verbindungsabdeckung
- Joint de dilatation / Expansion compensating element / Dehnungsteilstück
- ◁ Capot de fermeture / End cap / Endkappe
- \*\* Suspension supplémentaire / Additional sliding suspension / Zusätzliche Gleitauflängung

### Maintenance

This element does not require any special maintenance.

## Bracket

Ensures the mechanical link connection between the structure of the frame and the sliding hangers, fixes the position of the line in relation with the running rail.

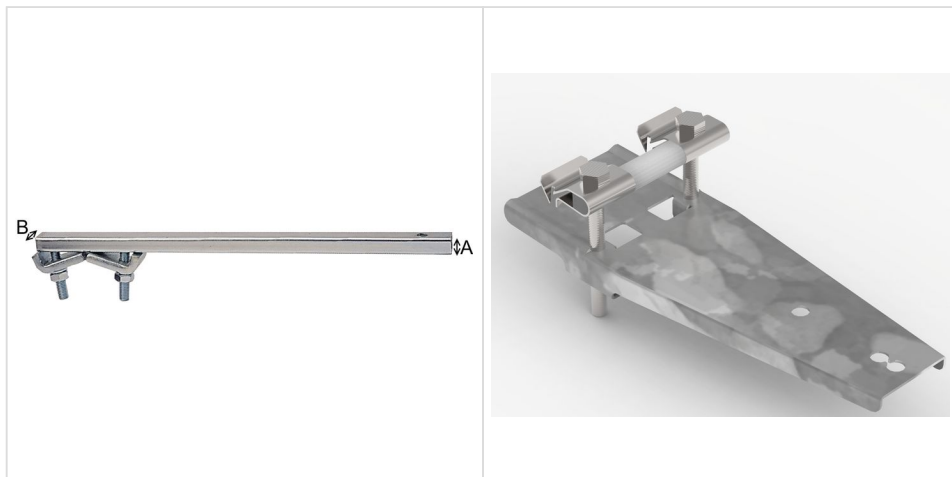

### Description

The fixing bracket allows to maintain the clearance between the line and the travel path. This clearance must be as parallel as possible. The Bracket must be chosen according to the wing-thickness of the beam on which it is attached, according to the centre distance between the beam and Mobilis and according to the weight to support. The standard bracket requires access from both sides of the beam for tightening the tightening plates. The position of the hole must be adjusted in relation to the running rail. 2 section profiles are available and will be selected based on the load to be supported (weight of element, number of suspensions by element, trolley, parasitic load - ice). The fast assembling clamped bracket requires access from only one side, in abutment to the screws. The hole is automatically positioned in relation to the beam edge. Restrictions of use of the fast assembling bracket: - only for interior service - not for line with expansion joint - not for line with dust protection lips - not for lines with transfer elements.

### Categorie

Standard

### Avantage n°1

Available in fast assembling version

### Avantage n°2

Various lengths available

---

## Références et compatibilités

### Références et variantes

The following references include several types of supports: fast assembling or not, and for beams up to 20mm or 32mm of thickness.

## Références et variantes

Reference	Type of mounting	Overall length	Allowable beam thickness	Section A x B	Weight	Compatible intensities
ME1700	Standard	380	6 to 20mm	14 x 20 mm	0,5 kg	12A - 160A
ME1750	Standard	500	6 to 20mm	14 x 20 mm	0,6 kg	12A - 60A 100A - 160A on IPE550 mini
ME1760	Standard	600	6 to 20mm	28 x 30 mm	1,0 kg	12A - 200A
ME1765	Standard	600	15 to 32mm	28 x 30 mm	1,0 kg	12A - 200A
ME1780	Standard	850	6 to 20mm	28 x 30 mm	1,2 kg	12A - 200A
ME1785	Standard	850	15 to 32mm	28 x 30 mm	1,2 kg	12A - 200A
ME1799	Fast	240	7 to 40mm	-	0,4kg	12A - 200A

## Données techniques

### Données techniques

Brackets in 1000mm length are Available on request. The bending resistance of these brackets have to be considered on a case-by-case basis according to the cantilever distance and the overhung load.

### Encombrement



**Température d'utilisation**

-30°C to +75°C

**Matière**

Zinc coated steel

**Fichier 3D à télécharger**

[http://catalogue.fels.fr/medias/produits/Support\\_a\\_pince\\_F.7z](http://catalogue.fels.fr/medias/produits/Support_a_pince_F.7z)

## Montage

### Outils nécessaires au montage

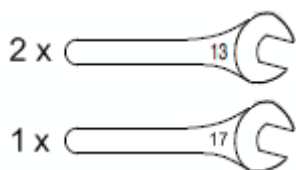

### Outils nécessaires au démontage

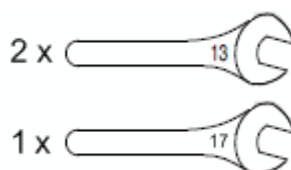



**Règle d'installation 1**

Number and position according to the rules for placing the sliding hangers.

**Règle de montage 1**

Align the assembling holes of the sliding hangers in parallel to the travel path

**Règle de montage 2**

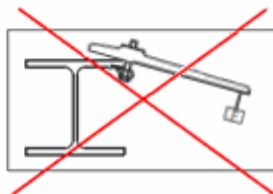
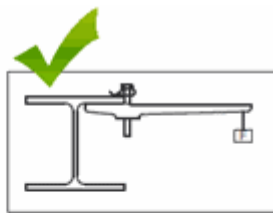
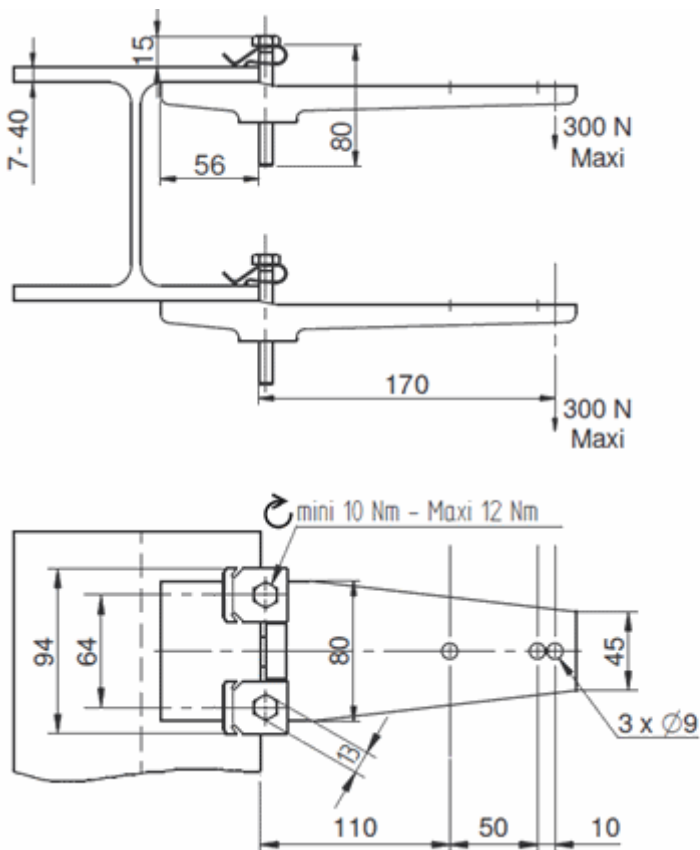

**Règle de montage 3**

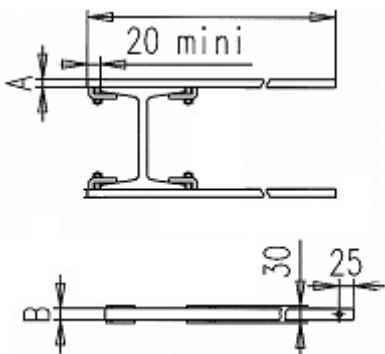

**Maintenance**

This element does not require any special maintenance.

## End-line feed

Interface accessory for the electrical connection of the line at end of line.



### Description

For electrical connection of the installation end of line. Feeds in line are also available. For copper and aluminum flexible cable. For use with aluminum cables, provide bi-metallic cable eye stiffeners and cables of minimum section of 16mm<sup>2</sup> in conformance with Standard NF EN 60204-32 §13.2.

### Categorie

Standard

### Avantage n°1

Horizontal cable outlet (outlet through bottom possible), M25, M32, M40 cable glands

### Avantage n°2

IP 23: Index of protection against access to dangerous parts and rain

## Références et compatibilités

Références et variantes

<b>REFERENCES</b>	Standard manufacturing	ME 1200	ME 1230	ME 1250
	For curves	ME 1200-CO	ME 1230-CO	ME 1250-CO
	With protection brushes	ME 1200-LV	ME 1230-LV	ME 1250-LV
	For curve, with protection brushes	ME 1200-COLV	ME 1230-COLV	ME 1250-COLV
	Without earth	ME 1200-B	ME 1230-B	ME 1250-B
	Cable output orientation	horizontal		
	Size of cable gland	M25	M32	M40
	Cable diameter	13 - 18mm	15 - 25mm	21 - 32mm
	Measure A	182-189mm	186-193mm	193-203mm
	Measure B	134mm	138mm	148mm

Other variants: Vertical outlet downwards: please enquire.

Included :

identification sticker of the poles,

Not included:

Screws accessories for 5<sup>th</sup> pole: ME1360.

Screws and bolts of M5 connection: use the connection parts fitted on the straight elements.

Cable eye stiffeners of connection: Ø5 (tinned copper for copper cables and bimetallic copper-aluminum for aluminium cables)

**Disponible avec lèvres ?**

compatible

**Disponible en version haute température ?** compatible

**Disponible en version sans terre ?**

oui

**Disponible en version courbe ?**

compatible

# Données techniques

## Données techniques

Area on line with no access to the trolley: 35mm. Extra Length in end of line: 148mm, Tightening capacity of the cable glands: M25 for cables Ø13 to 18 mm, M32 for cables Ø18 to 25 mm and M40 for cables Ø22 to 32mm.

## Encombrement

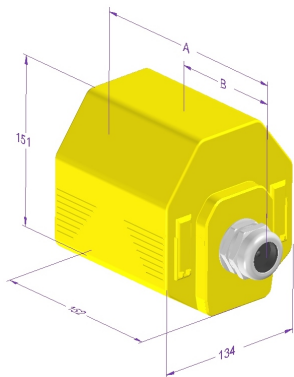

**Encombrement L x H x Z**

134 x 151 x 203

**Poids**

0,4 kg

**Tension d'emploi**

750V

**Température d'utilisation**

-30°C to +75°C

**Calibre**

12A, 20A, 40A, 60A, 100A

**Matière**

Self-extinguishing thermoplastic

# Montage

## Outils nécessaires au montage

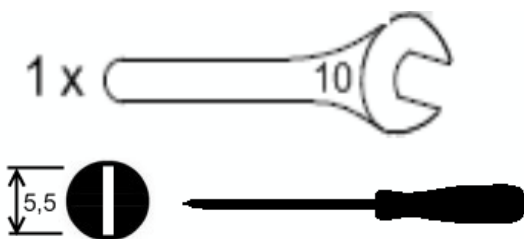

## Outils nécessaires au démontage

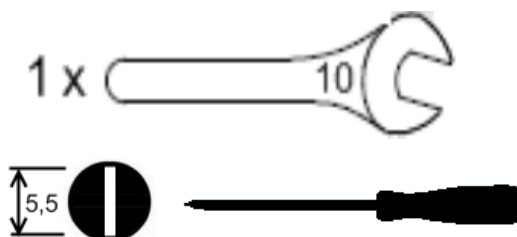

## Règle d'installation 1

For choosing an end- line feeding point, consider the overall length of the line for calculating the voltage drop. Provide a flexible wiring so as not to impede the expansion of the line. Fitted in place of an end-cap.

## Règle de montage 1

The cable should not impede the free expansion of the line: provide adequate free loop of flexible cable. Provide cable eye stiffeners of connection Ø5mm, screws and bolts not included.

**10 Alimentation en bout**  
*End feed unit*  
 Kopfeinspeisung

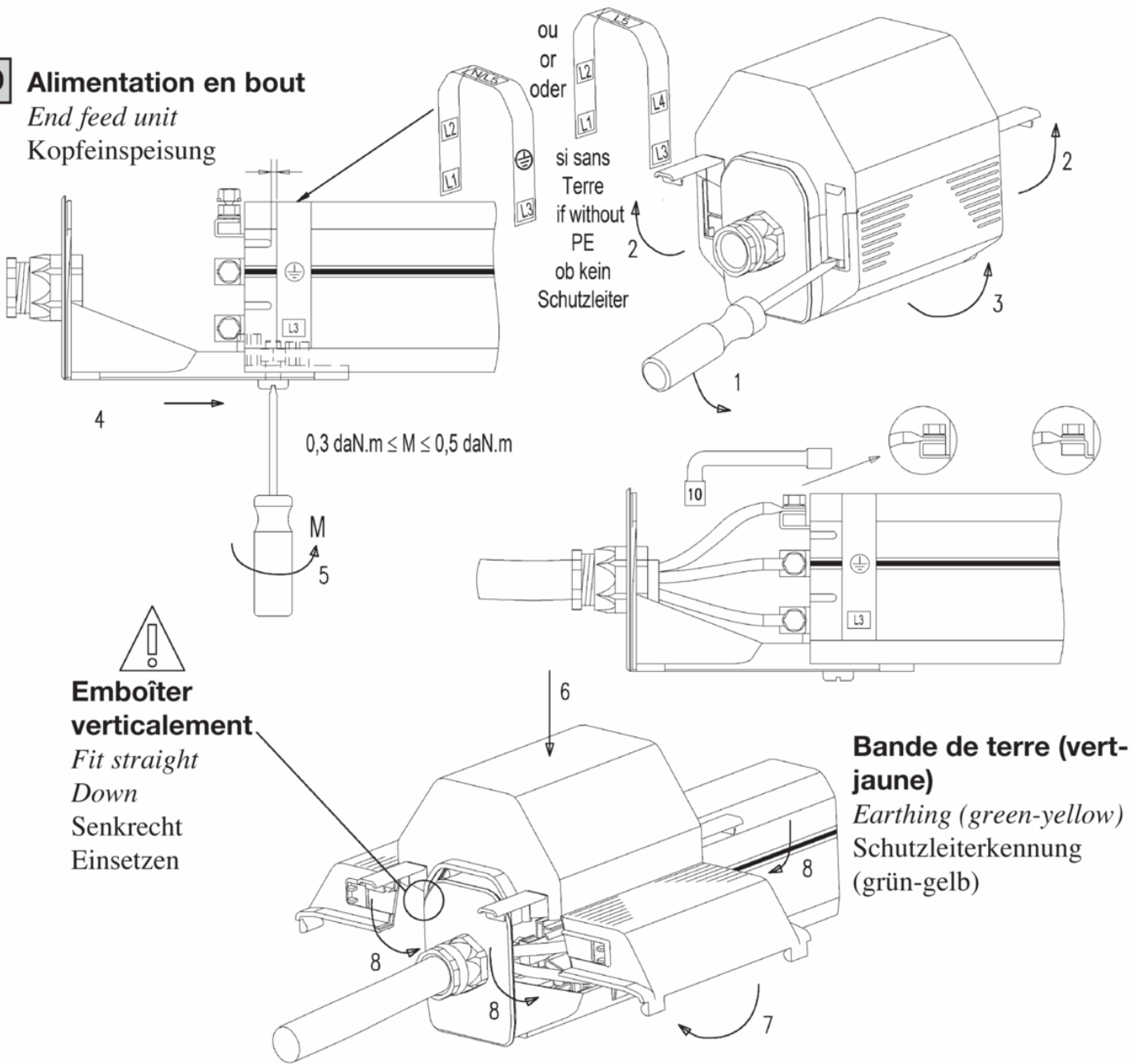

**Maintenance**

See the rules of maintenance of the lines

## M25-M32 in-line feed

Interface accessory for the electrical connection of the line on a connection in-line.

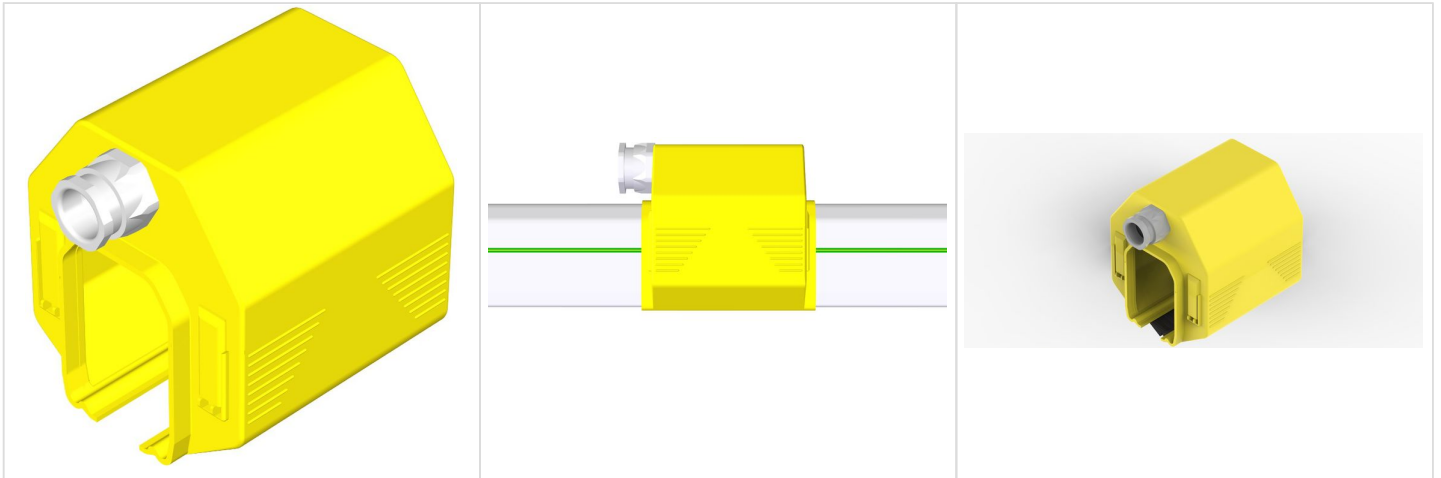

### Description

To be inserted in replacement of a covering flange for the electrical connection of the installation in-line. End feeds are also available. For cable of flexible copper and flexible aluminum. For use with aluminum cables, provide bi-metallic cable eye stiffeners and cables of minimum section 16mm<sup>2</sup> in accordance with Standard NF EN 60204-32 §13.2.

### Categorie

Standard

### Avantage n°1

In-line feed reduces the voltage drops

### Avantage n°2

IP 23: Index of protection against access to dangerous parts and rain

## Références et compatibilités



# Données techniques

## Données techniques

Feeding with direct connection by eye terminal Ø5mm (no connection plate), screws and bolts not included. Appropriate for the standard and high temperature ranges. Tightening capacity of the cable glands: M25 for cables Ø13 to 18 mm and M32 for cables Ø18 to 25 mm.

## Encombrement

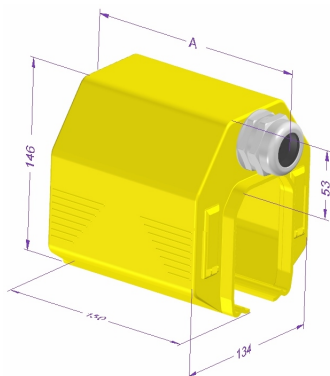

<b>Encombrement L x H x Z</b>	134 x 146 x 178	<b>Poids</b>	0,3 kg
<b>Tension d'emploi</b>	750V	<b>Température d'utilisation</b>	-30°C to +75°C
<b>Calibre</b>	12A, 20A, 40A, 60A, 100A		
<b>Matière</b>	Self-extinguishing thermoplastic		

# Montage

## Outils nécessaires au montage

## Outils nécessaires au démontage

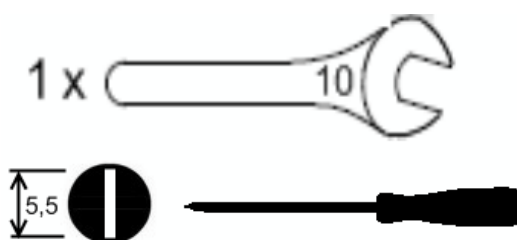

## Règle d'installation 1

Providing one or more feeding point in line rather than end-of-line reduces the voltage drop ( $\Delta U = Lt \cdot \sqrt{3} \cdot Z \cdot I$ ) and allows to choose a lower intensity because the length 'Lt' taken into account in the calculation varies according to the number of feed boxes. Providing a feeding point midway in the line reduces by half the voltage drop, as the 'Lt' section taken into account equals half the length of the line. For more than one feeding point in line, please review the following graph for the position of the points and related voltage drops.



## Image d'installation

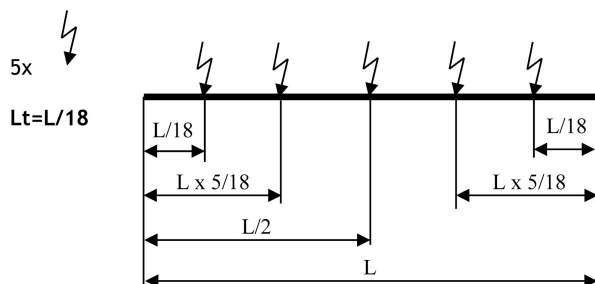
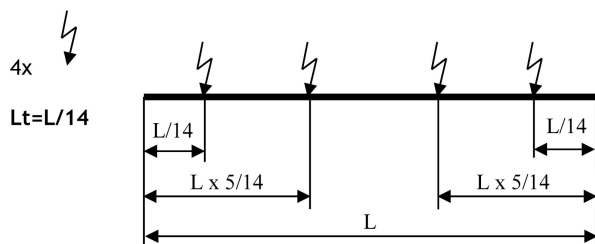
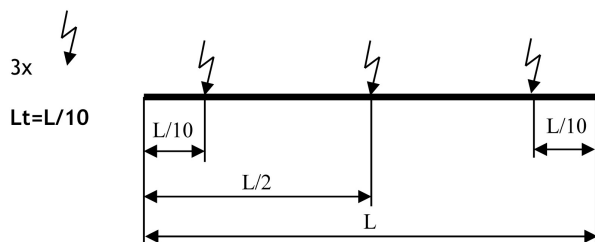
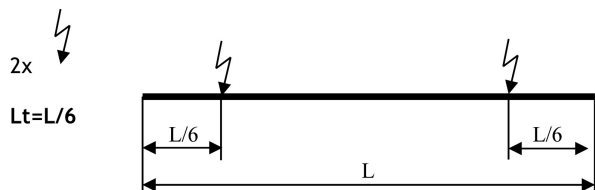
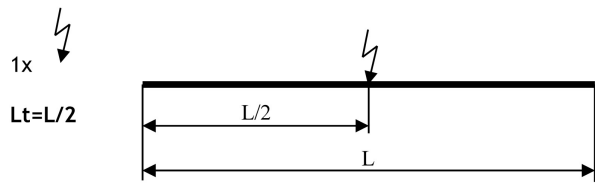
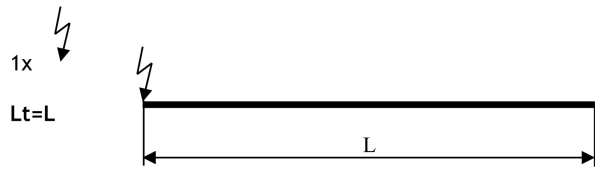

## Règle de montage 1

The cable should not impede the free expansion of the line: provide adequate free loop of flexible cable. Provide cable eye stiffeners of connection Ø5mm, screws and bolts not included.

## Règle de montage 2

### 9 Alimentation en cours

In-line feed box  
Streckeneinspeisung

ME 1300-ME 1330

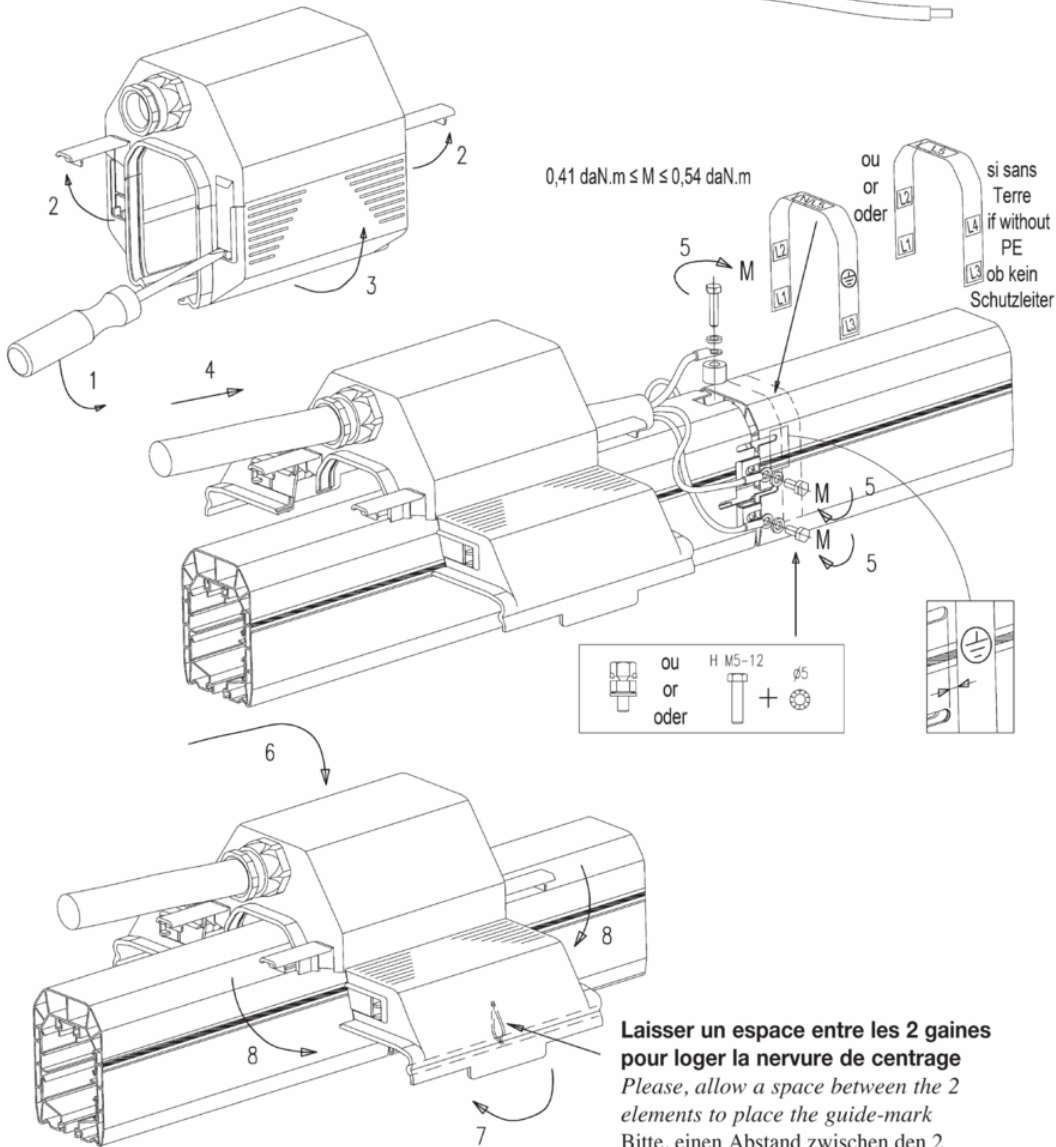
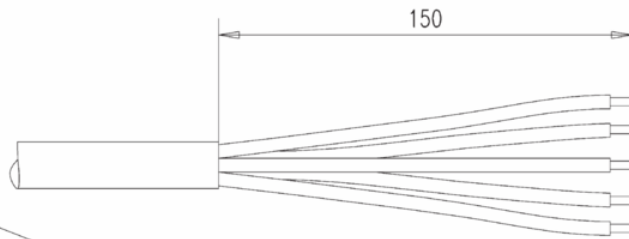
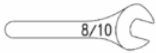

**Laisser un espace entre les 2 gaines pour loger la nervure de centrage**

*Please, allow a space between the 2 elements to place the guide-mark*

Bitte, einen Abstand zwischen den 2

Elementen für die Aufnahme der

Zentrierrippe berücksichtigen

## Maintenance

See the rules of maintenance of the lines

## M40 in-line feed

Interface accessory for the electrical connection of the line at a junction in-line.

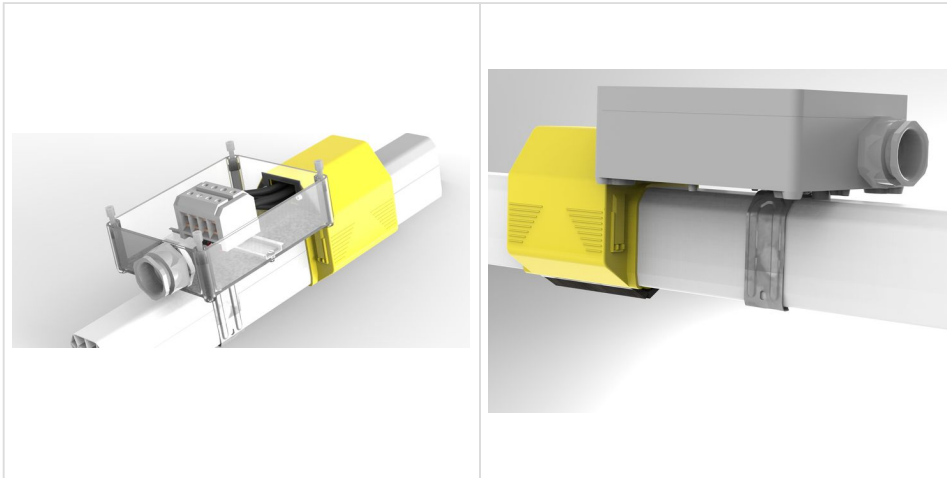

### Description

To be inserted in replacement of a covering flange for the electrical connection of the installation in-line. End feeds are also available. For cable of flexible copper and rigid aluminum. When aluminum cables are used, please request the specific instructions for rigid cables and provide cables of minimum section 16mm<sup>2</sup> in accordance with Standard NF EN 60204-32 S13.2.

### Categorie

Standard

### Avantage n°1

In-line feed reduces the voltage drops

### Avantage n°2

IP 23: Index of protection against access to dangerous parts and rain

---

## Références et compatibilités

<b>REFERENCES</b>	<b>Standard</b>	ME 1332	ME 1329
	<b>With protection brushes</b>	ME 1332-LV	ME 1329-LV
	<b>Without earth</b>	ME 1332-B	ME 1329-B
	<b>With protection brushes, without earth</b>	ME 1332-BLV	ME 1329-BLV
	<b>Number of poles</b>	4	5
	<b>Size of cable gland</b>	M40	M40
	<b>Cable diameter</b>	21 - 32mm	22 - 32mm

Identification sticker of the poles included  
 Screws of M5 connection and wires included  
 Connection with terminal block

**Disponible avec lèvres ?** oui  
**Disponible en version sans terre ?** oui

**Disponible en version haute température ?** compatible  
**Disponible en version courbe ?** non

# Données techniques

## Données techniques

Capacity of the terminal block: 35mm<sup>2</sup>, Tightening capacity of the cable gland: for cables Ø22 to 32mm.

## Encombrement

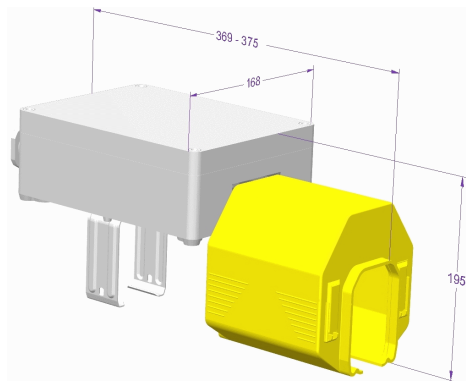

**Encombrement L x H x Z**

164 x 195 x 375

**Poids**

1,7 kg

**Tension d'emploi**

750V

**Température d'utilisation**

-30°C to +75°C

**Calibre**

12A, 20A, 40A, 60A, 100A

**Matière**

Self-extinguishing thermoplastics, zinc coated steel

# Montage

## Outils nécessaires au montage

## Outils nécessaires au démontage

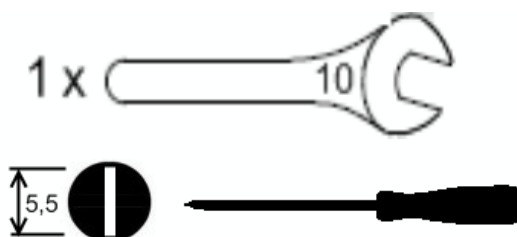
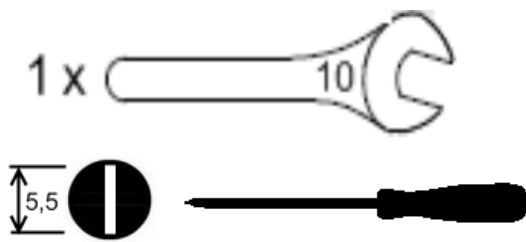

## Règle d'installation 1

Providing one or more feeding point in line rather than end-of-line reduces the voltage drop ( $\Delta U = L_t \cdot I \cdot Z$ ) and allows to choose a lower intensity because the length 'L<sub>t</sub>' taken into account in the calculation varies according to the number of feed boxes. Providing a feeding point midway in the line reduces by half the voltage drop, as the 'L<sub>t</sub>' length taken into account equals half the length of the line. For more than one feeding point in line, please review the following graph for the position of the points and related voltage drops. With the version for curves, no limit for the radius at the curve-straight element junction, otherwise minimum radius R... at the curve-curve junction.

## Image d'installation

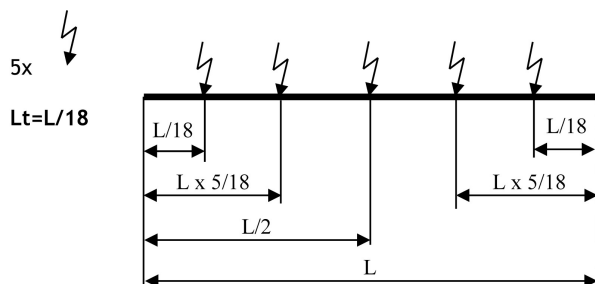
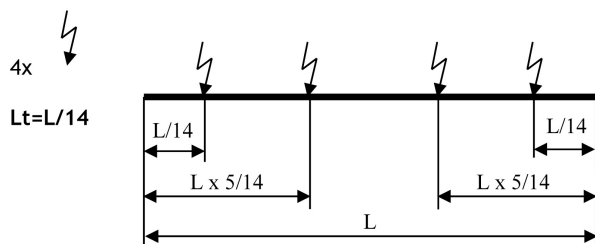
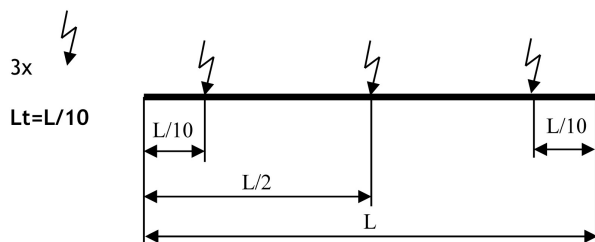
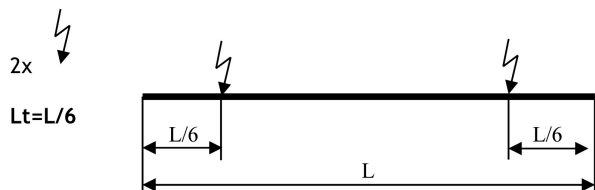
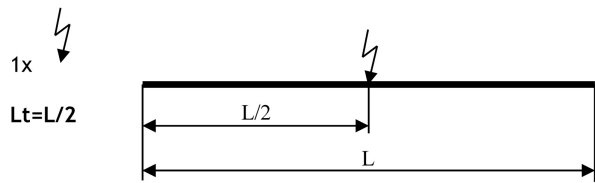
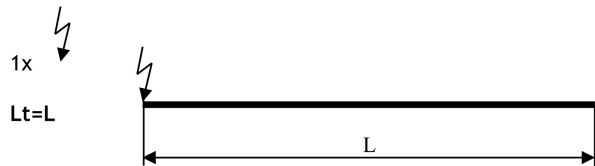

### Règle de montage 1

The cable should not impede the free expansion of the line: provide adequate free loop of flexible cable. If single wire aluminium cables are used (multistrand prohibited), use contact lubricant.

## Règle de montage 2

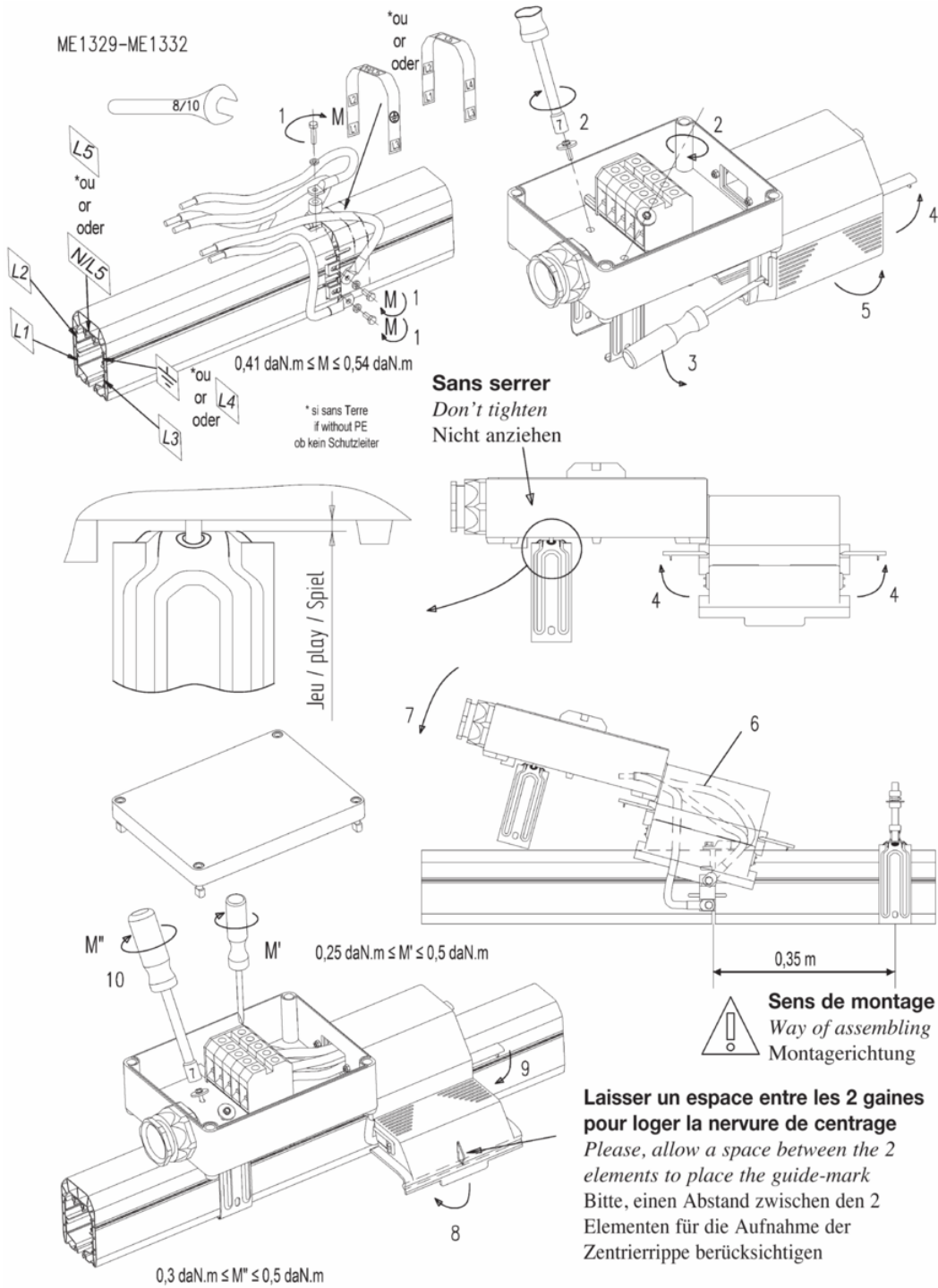

## Maintenance

See the rules of maintenance of the lines

## Pre -mounted feed box on straight element

Interface accessory for the electrical connection of the pre-mounted line on a straight element.



### Description

Pre-mounted on 1 or 4m of standard line element, renovation with 2m cable for standard version. Connecting box aside required. L 4m: provide 3 sliding hangers, L 1m: provide 2 sliding hangers.

### Categorie

Standard

### Avantage n°1

Prewired with flexible cable

### Avantage n°2

Delivered with cable of 2m length

## Références et compatibilités

### Références et variantes

The pre-mounted feed boxes are offered in standard versions of 1m or 4m using the references of the following table, for versions withstanding high temperature up to +75°C, add - HT after the reference, or for versions with dust protection lips, add - LV after the reference. Version without earth marking: add - B after the reference.

### Références et variantes

Intensity	Cable section	Ø cable	Cable length	B : Power position	Width A	Half width (earth side)	Length	Type 4 poles	Ref. 4 poles	Weight 4P	Type 5 poles	Ref. 5 poles	Weight 5P
100A	35 mm <sup>2</sup>	16 mm	2m	800mm	130 mm	65 mm	4m	2	ME1320	14 kg	2	ME1321	15,9 kg
130A	35 mm <sup>2</sup>	16 mm		200mm	192mm (4P), 241mm (5P)	96 mm (4P), 121mm (5P)	1m	1	ME1313	8 kg	1	ME1317	9,3 kg
				800mm	136 mm	65 mm	4m	2	ME1323	15,5 kg	2	ME1324	17,9 kg
160A	50 mm <sup>2</sup>	18 mm		200mm	192mm (4P), 241mm (5P)	96 mm (4P), 121mm (5P)	1m	1	ME1316	9,7 kg	1	ME1319	11,6 kg
				800mm	136 mm	65 mm	4m	2	ME1326	18,2 kg	2	ME1327	21,3 kg
200A TR	70 mm <sup>2</sup>	21 mm		200mm	192mm (4P), 241mm (5P)	96 mm (4P), 121mm (5P)	1m	1	ME8299-TR	12,9 kg	1	ME8294-TR	15,6 kg
			800mm	136 mm (4P), 241mm (5P)	65 mm (4P), 121mm (5P)	4m	2	ME8298-TR	23,8 kg	1	ME8295-TR	27,3 kg	

Disponible avec lèvres ?

oui

Disponible en version haute température ?

oui

Disponible en version sans terre ?

oui



---

## Données techniques

### Données techniques

Feeding width and weight are shown as dimension A and by the indications of the table of references.

### Encombrement

<b>Poids</b>	see table	<b>Tension d'emploi</b>	750V
<b>Température d'utilisation</b>	-30°C to +55°C		
<b>Calibre</b>	100A, 130A, 160A, 200A-TR		
<b>Matière</b>	Self-extinguishing thermoplastic, zinc coated steel		

### Fichier 3D à télécharger

[http://catalogue.fels.fr/medias/produits/boite\\_d\\_alimentation\\_premontee\\_sur\\_element\\_droit.7z](http://catalogue.fels.fr/medias/produits/boite_d_alimentation_premontee_sur_element_droit.7z)

---

## Montage

### Outils nécessaires au montage

### Outils nécessaires au démontage

### Règle d'installation 1

Fitted in place of a straight element. Provide a connecting box aside (not supplied). L = 4m: 3 sliding hangers. L = 1m: 2 sliding hangers. Providing one or more feeding point in line rather than end-of-line reduces the voltage drop ( $\Delta U = L \cdot I \cdot Z$ ) and allows to choose a lower intensity because the length 'Lt' taken into account in the calculation varies according to the number of feed boxes. Providing a feeding point midway in the line reduces by half the voltage drop, as the 'Lt' section taken into account is half the length of the line. For more than one feeding point in line, please review the following graph for the position of the points and related voltage drops.

## Image d'installation

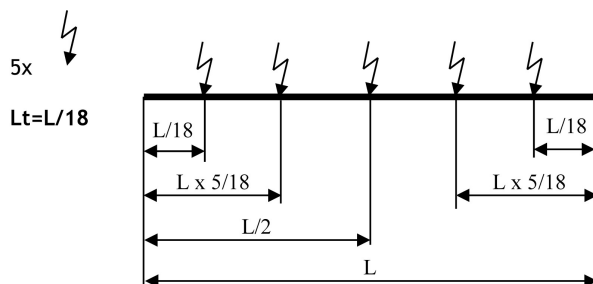
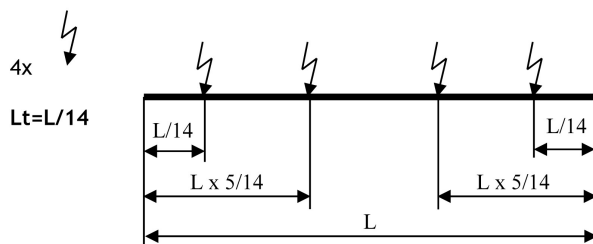
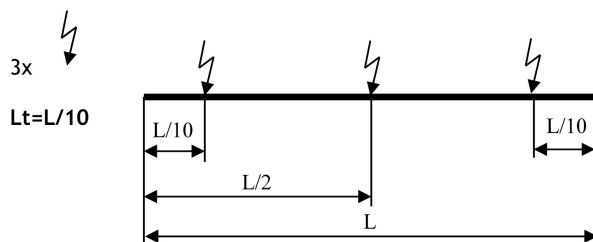
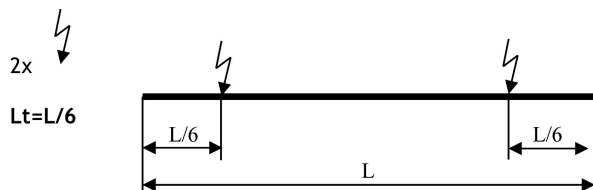
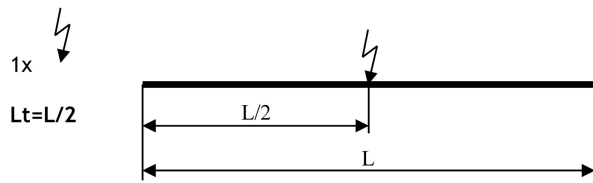
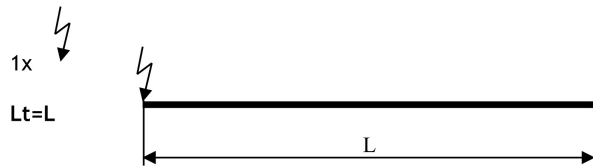

## Règle de montage 1

1. Clip-on the line in the sliding hangers, 2. Connect the line element at the ends, 3. Connect the cables in the box aside. The cable should not impede the free expansion of the line. Provide adequate free loop before the junction box.

## Règle de montage 2

**Alimentation pré-montée sur gaine / Feed Box premonted on line /**  
Einspeisung auf Schienenanänge vormontiert

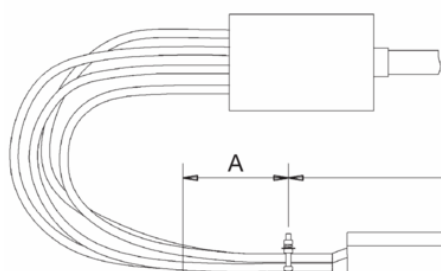

### Boîtier de raccordement déporté

*Additional terminal box*  
Zusätzlicher Klemmenkasten

130A	1m	ME1313
	4m	ME1343
160A	1m	ME1316
	4m	ME1346
200A	1m	ME8299-TR
	4m	ME8279-TR

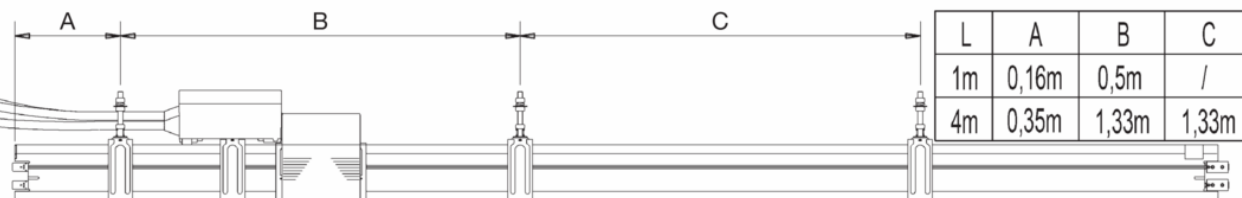

**La disposition des câbles et du boîtier ne doit pas entraver la dilatation. Conserver un jeu mini de 60mm (1m) / 200mm (4m)**

*The configuration of the cables and terminal box must not impede the expansion. Keep a minimum play of 60mm (1m) / 200mm (4m)*

Die Anordnung der Kabel und des Klemmkastens darf die Ausdehnung nicht behindern. Mindestspielraum von 60mm (1m) / 200mm (4m) einhalten

## Maintenance

See the rules of maintenance of the lines

## Introduction gate

Allows trolleys to be removed or inserted in-line.

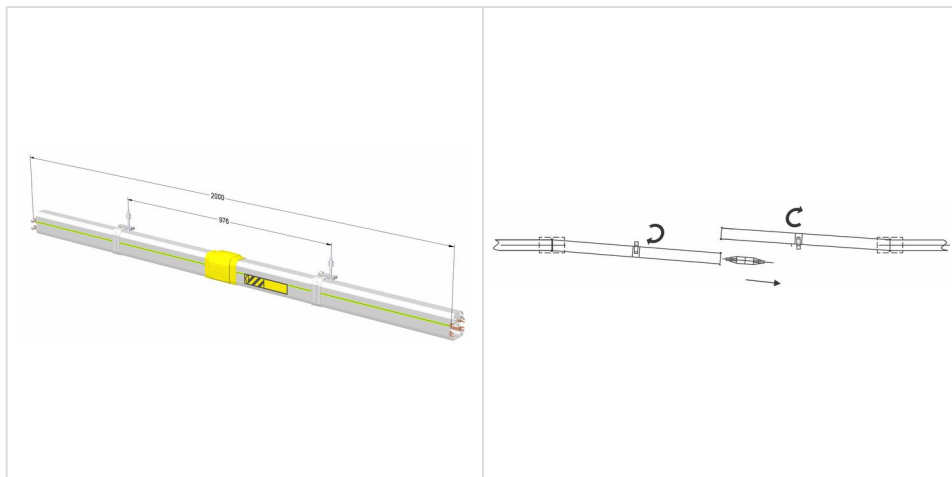

### Description

Introduction gates are designed to facilitate access to the collector trolleys, mainly for maintenance purposes. The introduction gate has a standard length of 2m and is supported by 2 special sliding hangers for the lateral displacement of the two line sections. It replaces a standard element of 2 meters. The connexion screw are reusable. Caution: the electrical supply to the line must be cut off before opening the introduction gate.

### Categorie

Standard

### Avantage n°1

Easy extraction of the trolley from the line

### Avantage n°2

Sliding hangers included

## Références et compatibilités

### Références et variantes

The references and their alternative versions are described in the following table

### Références et variantes

Introduction gate	Number of poles	20A	40A	60A	100A	130A	160A	200A-TR
Standard	4P	ME4702	ME4704	ME4706	ME4710	ME4713	ME4716	ME8296-TR
	5P	ME4752	ME4754	ME4756	ME4750	ME4753	ME4757	ME8297-TR
With protection lips	4P	ME4702-LV	ME4704-LV	ME4706-LV	ME4710-LV	ME4713-LV	ME4716-LV	ME8296-TR-LV
	5P	ME4752-LV	ME4754-LV	ME4756-LV	ME4750-LV	ME4753-LV	ME4757-LV	ME8297-TR-LV
(75°C) High temperature	4P	ME4702-HT	ME4704-HT	ME4706-HT	ME4710-HT	ME4713-HT	ME4716-HT	ME8296-TR-HT
	5P	ME4752-HT	ME4754-HT	ME4756-HT	ME4750-HT	ME4753-HT	ME4757-HT	ME8297-TR-HT
Length		2m						
Max. Weight	5P	4,2 kg	3,8 kg	4,4 kg	4,8 kg	6 kg	6,6 kg	8,4 kg

Disponible avec lèvres ?

oui

Disponible en version haute température ?

oui

Disponible en version sans terre ?

oui, ajouter -B derrière la référence standard

## Données techniques

### Données techniques

The introduction gate adds 0.6 kg to the weight of the standard equivalent element of 2m.

### Poids

According to reference

### Tension d'emploi

selon gamme choisie **Température d'utilisation** selon gamme choisie °C to +°C

### Calibre

20A, 40A, 60A, 100A, 130A, 160A, 200A-TR

### Matière

Self-extinguishing PVC light grey, self-extinguishing thermoplastic, zinc coated steel, copper

## Montage

### Outils nécessaires au montage

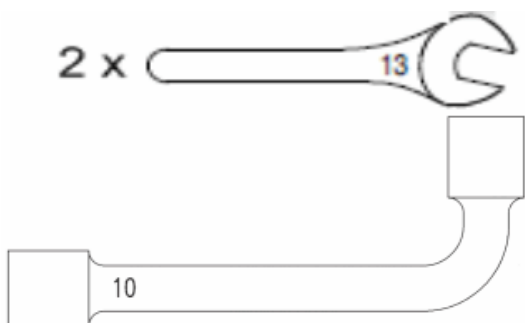

### Outils nécessaires au démontage

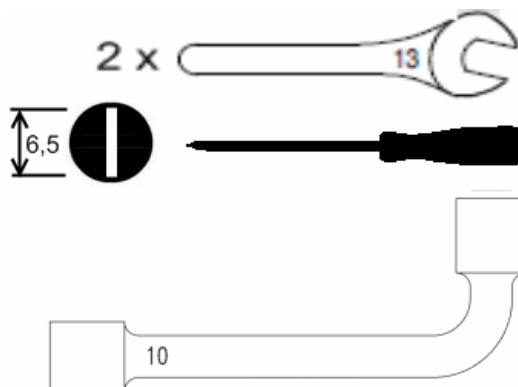

### Règle d'installation 1

To be located generally in a maintenance area

### Règle de montage 1

1. Install the swivelling suspensions 2. Clip-on the straight elements of the introduction gate in the swivelling sliding hangers 3. Connect the straight elements to each other 4. Position the covering flange 5. Lock the swivelling sliding hanger.

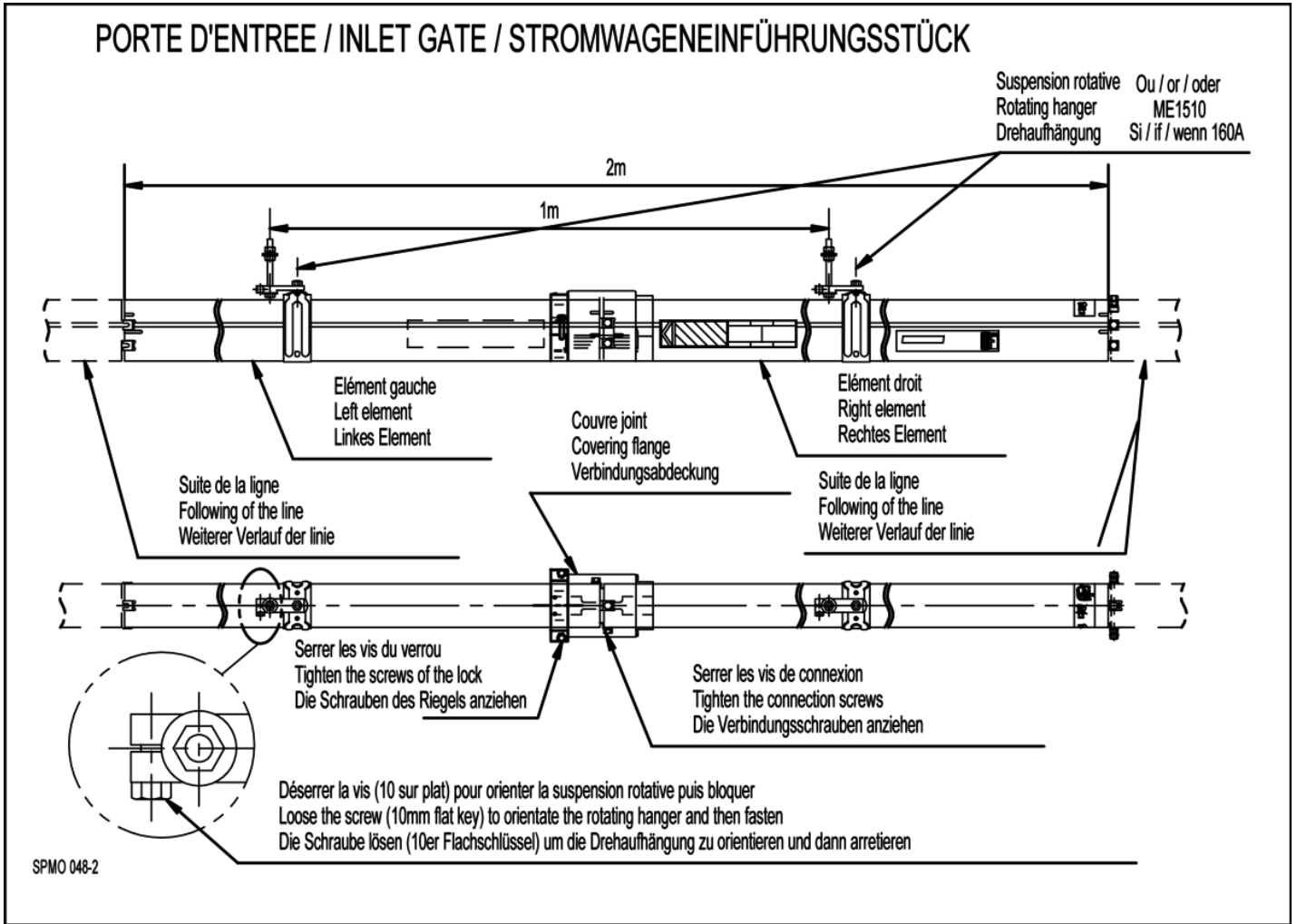

**Maintenance**

See the rules of maintenance of the lines

## Ventilation element

Limits condensation in a line with a warm section (interior) and a cold section (exterior) of a building.

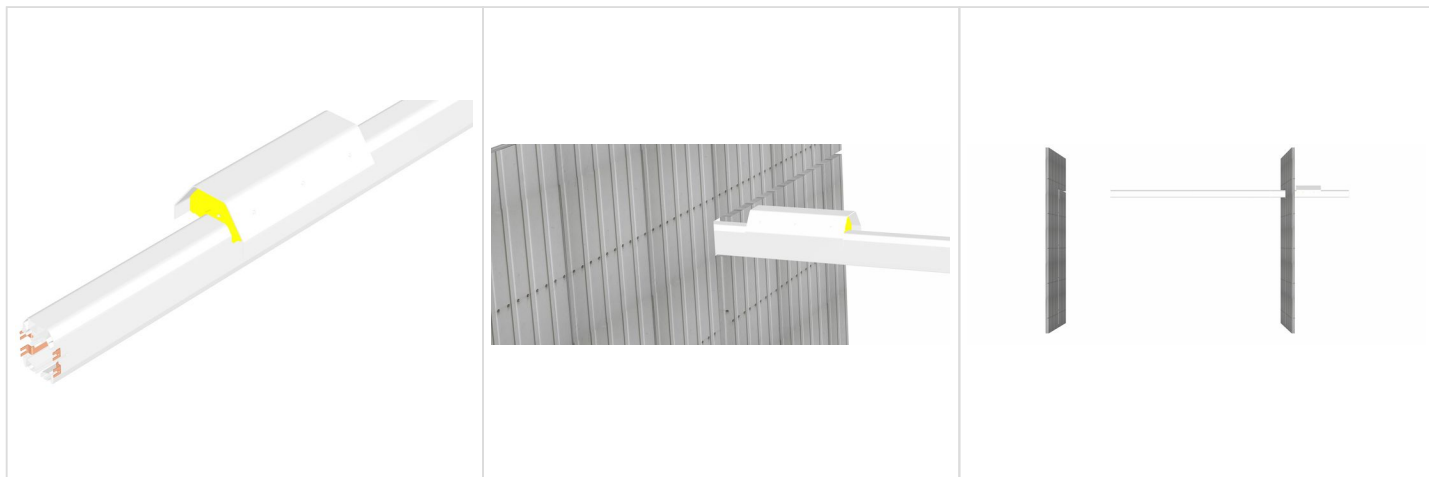

### Description

The purpose of the ventilation element is to limit condensation in a line with a warm section (inside the factory) and a cold section (outside the factory).

### Categorie

Standard

### Avantage n°1

Limits condensation

### Avantage n°2

Pre-mounted

---

## Références et compatibilités

### Références et variantes

The ventilation element is available for standard version of 1m and 4m with the ventilation element fitted midway of the line, alternatives are available for High-Temperature (75°C) or with lips. See the references below.

## Références et variantes

Type	Length	Measure A	Number of poles	12A	20A	40A	60A	100A	130A	160A	200A TR
Standard	1m	350mm	4 poles	ME5314	ME5310	ME5300	ME5301	ME5302	ME5303	ME5312	ME5304-TR
			5 poles	ME5315	ME5311	ME5305	ME5306	ME5307	ME5308	ME5313	ME5309-TR
	4m	1850mm	4 poles	ME5352	ME5345	ME5340	ME5341	ME5342	ME5343	ME5347	ME5344-TR
			5 poles	ME5353	-	ME5350	ME5346	-	-	ME5348	-
With protection lips	1m	350mm	4 poles	ME5314-LV	ME5310-LV	ME5300-LV	ME5301-LV	ME5302-LV	ME5303-LV	ME5312-LV	ME5304-TR-LV
			5 poles	ME5315-LV	ME5311-LV	ME5305-LV	ME5306-LV	ME5307-LV	ME5308-LV	ME5313-LV	ME5309-TR-LV
	4m	1850mm	4 poles	ME5352-LV	ME5345-LV	ME5340-LV	ME5341-LV	ME5342-LV	ME5343-LV	ME5347-LV	ME5344-TR-LV
			5 poles	ME5353-LV	-	ME5350-LV	ME5346-LV	-	-	ME5348-LV	-
High temperature (75°C)	1m	350mm	4 poles	ME5314-HT	ME5310-HT	ME5300-HT	ME5301-HT	ME5302-HT	ME5303-HT	ME5312-HT	ME5304-TR-HT
			5 poles	ME5315-HT	ME5311-HT	ME5305-HT	ME5306-HT	ME5307-HT	ME5308-HT	ME5313-HT	ME5309-TR-HT
	4m	1850mm	4 poles	ME5352-HT	ME5345-HT	ME5340-HT	ME5341-HT	ME5342-HT	ME5343-HT	ME5347-HT	ME5344-TR-HT
			5 poles	ME5353-HT	-	ME5350-HT	ME5346-HT	-	-	ME5348-HT	-
Without earth marking	1m	350mm	4 poles	ME5314-B	ME5310-B	ME5300-B	ME5301-B	ME5302-B	ME5303-B	ME5312-B	ME5304-TR-B
			5 poles	ME5315-B	ME5311-B	ME5305-B	ME5306-B	ME5307-B	ME5308-B	ME5313-B	ME5309-TR-B
	4m	1850mm	4 poles	ME5352-B	ME5345-B	ME5340-B	ME5341-B	ME5342-B	ME5343-B	ME5347-B	ME5344-TR-B
			5 poles	ME5353-B	-	ME5350-B	ME5346-B	-	-	ME5348-B	-

Disponible avec lèvres ? oui

Disponible en version haute température ? oui

Disponible en version sans terre ? oui

Disponible en version courbe ? non

## Données techniques

### Données techniques

Add 0.5 kg to the weight of the standard equivalent element

### Encombrement

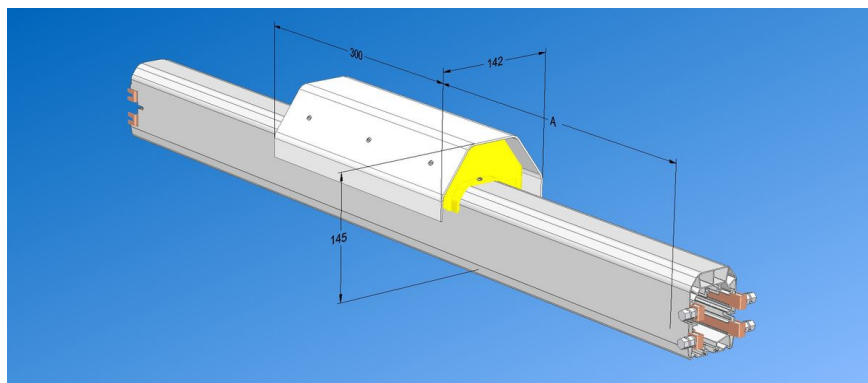

Encombrement L x H x Z

142 x 145 x 300

Poids

According to reference

Tension d'emploi

According to reference

Calibre

12A, 20A, 40A, 60A, 100A, 130A, 160A, 200A-TR

Matière

PVC and self-extinguishing thermoplastic, copper



# Montage

## Outils nécessaires au montage

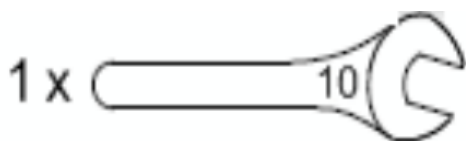

## Outils nécessaires au démontage

### Règle d'installation 1

The ventilation element is to be fitted like a standard element at the exit of the building (at the start of the cold area). The edge of the PVC cap must stand in the cold area at a distance of 200 to 500 mm from the hot area. Provide 2 sliding hangers, with a centre axis distance of 500mm for a 1m element, and of 2m for a 4m element.

### Règle d'installation 2

1. Insérer les gaines dans les suspensions, 2. Connecter les gaines

### Règle de montage 1

The edge of the PVC cap must be installed in the cold area at a distance of 200 - 500 mm from the hot area. The element is supported by 2 sliding hangers with a centre axis distance of 500 mm for 1m elements, 1000mm for 4m elements. 1. Insert the lines in the sliding hangers, 2. Connect the lines.

### Maintenance

See the rules of maintenance of the lines

## Expansion joint

Absorbs the difference in expansion between the line and the carrying structure.



### Description

The expansion joint is a line accessory which is designed to absorb the difference in expansion between the support structure and the Mobilis Elite line within the whole temperature range of the product, thereby ensuring the continuity of the electrical supply for the conductors and also the mechanical continuity for the sliding of the brushes and the trolley guides. In all cases, an expansion joint requires the use of an extra single current collector to guarantee the current capacity and the quality of the electric contact at the cross-over point of the expansion joint. The length of the line section is, among other factors, dependent on the absorption capacity of the expansion joint. This is why line lengths without expansion joints cannot be reproduced between two fixed hangers on lines with expansion joints.

### Categorie

Standard

### Avantage n°1

Can be managed like 2m element

### Avantage n°2

Useless below 140m, even more for high intensities

## Références et compatibilités

### Références et variantes

References of standard version in the following table, add - LV after the reference to order with lips and - HT to order version for high temperature (up to +75°C instead of +55°C).

### Références et variantes

Intensity	20A		40A		60A		100A		130A		160A		200A-TR	
Max. length of line without expansion joint	140m		150m		150m		150m		250m		250m		250m	
Number of poles	4	5	4	5	4	5	4	5	4	5	4	5	4	5
Weight	6,4 kg	6,8 kg	6,0 kg	6,4 kg	6,5 kg	7,0 kg	7,6 kg	8,2 kg	8,7 kg	9,8 kg	8,9 kg	10,8 kg	11,4 kg	13,1 kg
Reference	ME8020	ME8520	ME8040	ME8540	ME8060	ME8560	ME8100	ME8510	ME8013	ME8513	ME8016	ME8516	ME8290-TR	ME8291-TR

Disponible avec lèvres ?

oui

Disponible en version haute température ?

oui

Disponible en version courbe ?

non

# Données techniques

## Données techniques

Maximum length of line without expansion joint:

Intensity	20A	40A	60A	100A	130A	160A	200A 200A TR
Single line	140 m	150 m	150 m	150 m	250 m	250 m	250 m
Line <b>with</b> circuit interruption	see rules about circuit interruptions						
Between curves standard version	70 m	35 m	35 m	20 m	20 m	20 m	20 m
Between curves HT version	70 m	30 m	30 m	20 m	20 m	20 m	20 m
Between transfert elements	20 m	20 m	20 m	20 m	20 m	20 m	20 m
Between curve/transfert element and line end	62 m	76 m	62 m	52 m	40 m	35 m	30 m

Selection of the number of expansion joints on a straight line:

Length Intensity	0 to 140m	141 to 150m	151 to 180m	181 to 200m	201 to 250m	251 to 270m	271 to 300m	301 to 360m	361 to 400m	etc.
20A, 20A HT	0 joint	1 joint		2 joints			3 joints		etc.	
40A, 40A HT, 60A, 60A HT	0 joint		1 joint		2 joints			3 joints		etc.
100A	0 joint		1 joint		2 joints			3 joints		etc.
100A HT	0 joint		1 joint	2 joints			3 joint		etc.	
130A à 200A	0 joint				2 joints		3 joints		etc.	
130A à 200A HT	0 joint				2 joints		3 joints		etc.	

### IN ALL CASES A LINE WITH AN EXPANSION JOINT MUST RESPECT 4 RULES :

- the length beyond the fixed hangers = half the length between the fixed hangers (well-balanced line)
- the length between 2 fixed hangers  $\leq 100$  m ( $\leq 90$  m for intensities of 100A, 130A, 160A and 200A in the high temperature version)
- the position of the expansion joint must be centred between 2 fixed hangers
- an extra single trolley must be used.

## Encombrement

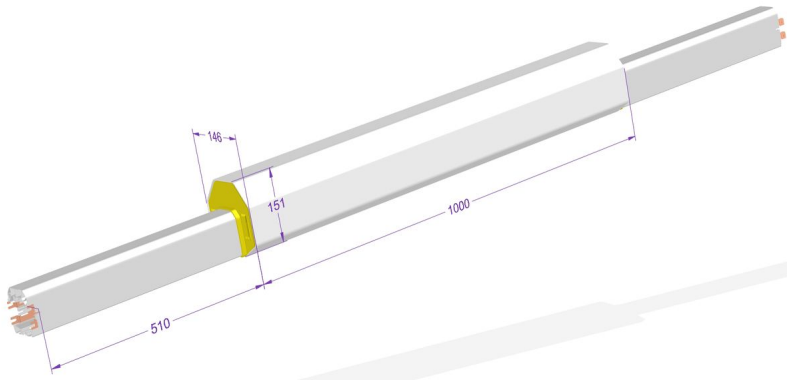

<b>Encombrement L x H x Z</b>	146 x 151 x 2000
<b>Poids</b>	According to reference
<b>Calibre</b>	20A, 40A, 60A, 100A, 130A, 160A, 200A
<b>Matière</b>	Self-extinguishing PVC and thermoplastic

### Fichier 3D à télécharger

[http://catalogue.fels.fr/medias/produits/Joint\\_de\\_dilatation\\_2010\\_06.7z](http://catalogue.fels.fr/medias/produits/Joint_de_dilatation_2010_06.7z)

---

## Montage

### Outils nécessaires au montage

### Outils nécessaires au démontage

### Règle d'installation 1

General case: Refer to the following diagram and the technical data for the layout of the expansion joints. Whenever the installation includes rigid cables impeding the expansion of the line, please request from us the Instruction Sheet SPST326.

## Image d'installation

### LIGNE AVEC 1 JOINT DE DILATATION :

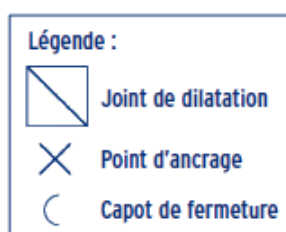
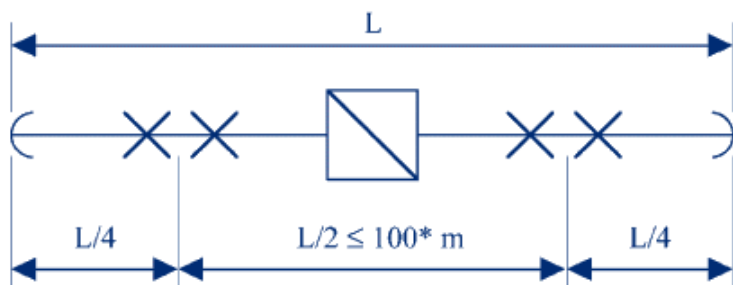

### LIGNE AVEC 2 JOINTS DE DILATATION :

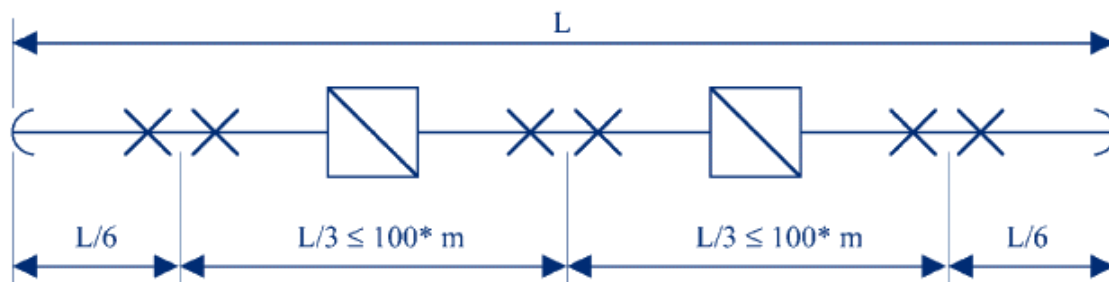

### LIGNE AVEC N JOINTS DE DILATATION :

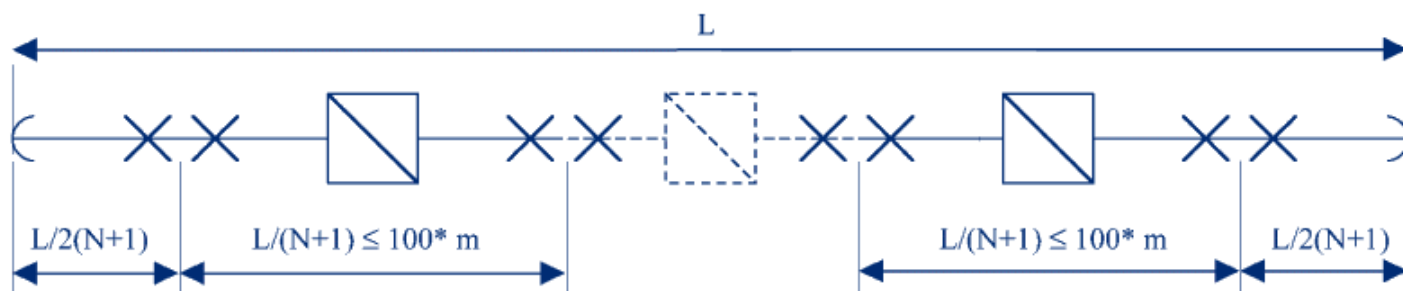

- \* 100 m dans la gamme -20°C à +55°C
- 90 m dans la gamme -30°C à +55°C ou -20°C à +75°C
- 75 m dans la gamme -30°C à +75°C

### Règle de montage 1

The expansion joint must always be placed exactly at mid-point between two fixed hangers.  
Increase the setting Length by +5mm if the surrounding working temperature is from -30°C to +75°C.

## Règle de montage 2

Température de montage Mounting temperature Montage-temperatur Temperatura de montaje	-20°C	-10°C	0°C	10°C	20°C	30°C	40°C	50°C	60°C
Longueur L Length L Länge L Longitud L	2005	2000	1995	1990	1985	1980	1975	1970	1965

Etirer l'élément jusqu'à la cote L (+5mm si  $-30^{\circ}\text{C} \leq \text{température ambiante} \leq +75^{\circ}\text{C}$ )

Drawout the element until the Length L (+5mm when  $-30^{\circ}\text{C} \leq \text{surrounding temperature} \leq +75^{\circ}\text{C}$ )

Das Element bis zur Länge L ausziehen (+5mm wenn  $-30^{\circ}\text{C} \leq \text{Umgebungstemperatur} \leq +75^{\circ}\text{C}$ )

Estirar la longitud hasta la cota L (+5mm si  $-30^{\circ}\text{C} \leq \text{temperatura de trabajo} \leq +75^{\circ}\text{C}$ )

## Maintenance

See the rules of maintenance of the lines

## Horizontal curve

Curved element bent in the horizontal plane with built-in conductors and pre-mounted connections.

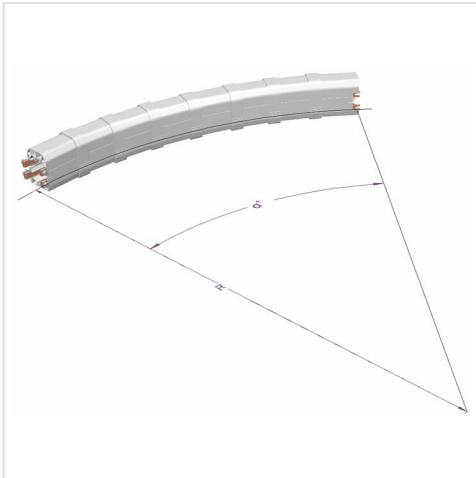

### Description

The curves are prepared in factory with the precise radius and angle of curve needed to maintain the feeding line at a constant distance from the travel path. Can be made for all intensities, standard range (maximum of 55°C) and high temperature (maximum of 75°C), with or without dust-protecting lips, with or without earth marking, for curve radii of 800mm (for lower radii, please enquire) up to infinity. They require the use of articulated trolleys. For intensities up to 130A, use curved covering flanges (ME2000-CO) or special feed boxes for curves (ME1300-CO, ME1330-CO, ME1332-CO or ME1329-CO) to be fitted to their junctions. Standard covering flanges and feed boxes for intensities 160A and 200A, the curves must be suspended by fixed hangers. Special curves can be made on request, including with straight sections at the ends, or vertical curves: please enquire.

### Categorie

Curves

### Avantage n°1

Fits exactly the layout of the circuit

### Avantage n°2

Allows to build all radii

## Références et compatibilités

### Références et variantes

The reference indicates the direction of the curved element required (earth inside or outside). The line should be set to make the earth side visible so as to facilitate access to the trolley connection plate. To order the version with lips, add '- LV' after the reference, for high temperature versions, add '- HT' after the reference, for versions without earth marking, add '- B' after the reference. When ordering, provide additional data for radius R and angle a.

### Références et variantes

Intensity		12A	20A	40A	60A	100A	130A	160A	200A-TR
4 poles	Ext. earth	ME4010	ME4020	ME4420	ME4620	ME4120	ME4140	ME4210	ME4220-TR
	Int. earth	ME4012	ME4022	ME4422	ME4622	ME4122	ME4142	ME4212	ME4222-TR
5 poles	Ext. earth	-	ME5020	ME5420	ME5620	ME5120	ME5140	ME5210	ME5220-TR
	Int. earth	-	ME5022	ME5422	ME5622	ME5122	ME5142	ME5212	ME5222-TR

Disponible avec lèvres ?

oui

Disponible en version haute température ?

oui

Disponible en version sans terre ?

oui

# Données techniques

## Données techniques

Please provide the following data: radius, angle, reference of the curve. Minimum radius: 800mm, for lower radii, please enquire. Maximum radius: no limit. Angle: up to 120° per element for intensity 20A to 100A, up to 90° for intensities 130A to 200A, above this, please enquire. The feeding line must maintain a constant distance from the travel path of the mobile device requiring current and must therefore follow a parallel path. The special curved elements (in the horizontal plane) are designed for this type of installation. Other features of the element: see section on straight elements. Maximum travel speed in the curves: 70m/min.

<b>Poids</b>	kg/m identique au standard, selon la longueur développée
<b>Tension d'emploi</b>	750V ou 440V selon gamme choisie
<b>Température d'utilisation</b>	-20°C to +55°C
<b>Calibre</b>	20A, 40A, 60A, 100A, 130A, 160A, 200A
<b>Matière</b>	Gray PVC and self-extinguishing thermoplastic

## Montage

### Outils nécessaires au montage

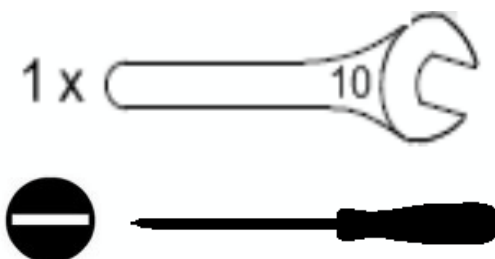

### Outils nécessaires au démontage

### Règle d'installation 1

ASSEMBLING: When assembling, scrupulously follow the specifications in the assembly instructions for curved elements SPMO 064. The curve must not move in the sliding hangers and shall be regarded as a fixed point. Always use fixed hangers to support it, quantities to be defined according to the 2 following rules: RULE 1: If the expanded length of the curve is equal to or below 2m AND if the angle of the curve is equal to or below 90°, provide 2 fixed hangers per curve. RULE 2: If the expanded length of the curve is above 2 m OR if the angle of the curve is above 90°, provide 3 fixed hangers per curve. ACCESSORIES: At each end of the curves, use special covering flanges for curves ME2000-CO, or special feed boxes for curves ME1300-CO, ME1330-CO ME1332-CO or ME1329-CO. It is imperative to always use articulated trolleys in all installations with curve, whatever the radius. EXPANSION JOINTS: When a straight line section is located between 2 curves, provide an expansion joint for lines with length above the values below.

### Image d'installation

Longueur Maxi de tronçon entre courbes sans joint de dilatation Maximal length between curves without expansion joint Maximale Länge zwischen Kurven ohne Dehnungsstück Longitud máxima de un tramo entre curvas sin junta de dilatación								
Calibre Intensity Stromstärke Calibre	12 A	20 A	40 A	60 A	100 A	130 A	160 A	200 A
Standard Estándar	70 m	70 m	35 m	35 m	20 m	20 m	20 m	20 m
H.T.	70 m	70 m	30 m	30 m	20 m	20 m	20 m	20 m



## Règle de montage 1

1. Insert the lines in the fixed hangers, 2. Connect the lines, 3. Tighten the screws of the fixed hangers, 4. Adjust the position carrier to have the trolley collector move smoothly.

## Maintenance

See the rules of maintenance of the lines

## Transfer elements

Ensures the passage of the trolley between discontinuous sections.



### Description

The purpose of the transfer elements is to ensure the trolley crosses over mechanically discontinuous line sections, for instance as in the case of switches. They can also be used for circuit interruptions (the advantage being that they actually cut the electrical circuit). However, transfer elements should in no case be used as electrical switches since they are not designed to resist electric arcing. Two types of transfer elements are offered: short transfer elements with short cones must be used when the facing cones are very close to each other with a minimum clearance of 10 mm and maximum clearance of 30 mm. Beyond that, use transfer elements with long cone. Safety: The contact with the protective earth conductor has priority over the other poles. The transfer element design does not allow access to the live parts, even from the front of the cone, due to the built-in insulators and safety distances. The transfer elements have a protection index of IP23 taking access to the dangerous parts into consideration, but do not offer any protection against solid foreign bodies (Ø12.5 ball test according to EN60529). Operator protection against access to the live brushes on the trolley and against the risk of mechanical blockages when crossing the interval between transfer elements must be provided by the customer. As the transfer elements are subjected to line expansion efforts, ME1500 fixed hangers must always be used together with rigid brackets such as ME1760 or ME1780, or welded brackets, for example. Furthermore, fixed hangers allow the transfer elements to withstand the stress caused by moving trolleys. The use of a special trolley for transfer element and/or of a special carrier for transfer element may be required, because of the dead length of the transfer elements and their geometry. Expansion joints can also be necessary beyond a certain distance between 2 transfer elements of the same line sector.

### Categorie

Transfer

### Avantage n°1

For feeding of switch or transfer systems

### Avantage n°2

Allows to introduce the trolley without any intervention on the line

## Références et compatibilités

### Références et variantes

The transfer elements are pre-mounted on line elements. The total length is 1 metre in the standard version, but special lengths are available on request. A transfer element with the earth on the right is identified by facing the transfer guide, with the opening at the bottom, when the green-yellow band is located on the right, and inversely for the transfer element with earth on the left. A switch (or circuit interruption element) will always include a transfer element with the earth on the right and a transfer element with the earth on the left. Add the references for special lengths using the length of the element, with the transfer element included. Available in versions without earth conductor, line with black band. Add '- B' after the reference (e.g. ME2525-B ). Caution! The transfer elements are not available in high temperature version. The following references are available:

## Références et variantes

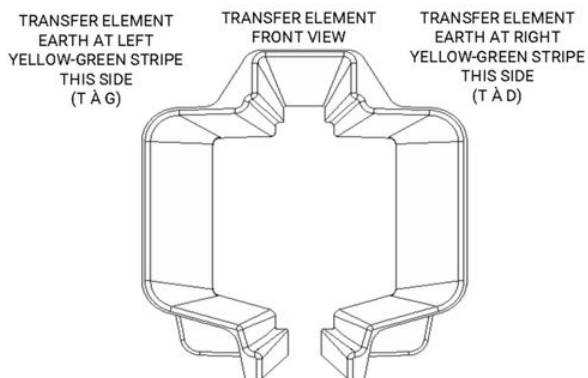

Type of transfer element			Short		Long		End opposite transfer element
			Standard 1m	Special length X m	Standard 1m	Special length X m	
20 A	4P	T à D	ME2501	ME2505	ME2551	ME2555	
		T à G	ME2502	ME2506	ME2552	ME2556	
	5P	T à D	ME2503	ME2507	ME2553	ME2557	
		T à G	ME2504	ME2508	ME2554	ME2558	
40 A	4P	T à D	ME2509	ME2513	ME2559	ME2563	
		T à G	ME2510	ME2514	ME2560	ME2564	
	5P	T à D	ME2511	ME2515	ME2561	ME2565	
		T à G	ME2512	ME2516	ME2562	ME2566	
60 A	4P	T à D	ME2517	ME2521	ME2567	ME2571	
		T à G	ME2518	ME2522	ME2568	ME2572	
	5P	T à D	ME2519	ME2523	ME2569	ME2573	
		T à G	ME2520	ME2524	ME2570	ME2574	
100 A	4P	T à D	ME2525	ME2529	ME2575	ME2579	
		T à G	ME2526	ME2530	ME2576	ME2580	
	5P	T à D	ME2527	ME2531	ME2577	ME2581	
		T à G	ME2528	ME2532	ME2578	ME2582	
130 A	4P	T à D	ME2533	ME2537	ME2583	ME2587	
		T à G	ME2534	ME2538	ME2584	ME2588	
	5P	T à D	ME2535	ME2539	ME2585	ME2589	
		T à G	ME2536	ME2540	ME2586	ME2590	
160 A	4P	T à D	ME2601	ME2606	ME2610	ME2613	
		T à G	ME2602	ME2607	ME2611	ME2614	
	5P	T à D	ME2603	ME2608	ME2612	ME2615	
		T à G	ME2604	ME2609	ME2613	ME2616	
200A TR	4P	T à D	ME2541-TR	ME2545-TR	ME2591-TR	ME2595-TR	
		T à G	ME2542-TR	ME2546-TR	ME2592-TR	ME2596-TR	
	5P	T à D	ME2543-TR	ME2547-TR	ME2593-TR	ME2597-TR	
		T à G	ME2544-TR	ME2548-TR	ME2594-TR	ME2598-TR	

All transfer elements are available with protection lips.  
 To order, add "-LV" after the reference.  
 Complete special reference lengths with the length of the element, transfer cone included.  
 Available in version without earth, with black stripe.  
 Add "-B" behind reference (example: ME2525-B)  
**Warning!** Transfer elements are not available in high temperature version.

**Disponible avec lèvres ?** oui

**Disponible en version sans terre ?** oui

**Disponible en version haute température ?** non

**Disponible en version courbe ?** oui

# Données techniques

## Données techniques

Dead length: short transfer elements: 215mm, long transfer elements: 290mm. Weight: identical to the standard element of the same length. Index of protection IP23, as far as access to dangerous parts is concerned, but does not offer protection against ingress of foreign solid bodies (ball test Ø12.5 in conformance with EN60529). Travel speed in the transfers: maximum 70 m/min (beyond that, enquire).

## Encombrement

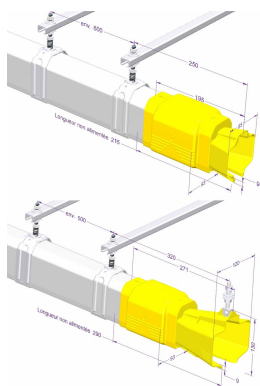

<b>Poids</b>	Identique à celui des éléments droits de même longueur		
<b>Tension d'emploi</b>	750V	<b>Température d'utilisation</b>	-20°C to +55°C
<b>Calibre</b>	20A, 40A, 60A, 100A, 130A, 160A, 200A		
<b>Matière</b>	Self-extinguishing PVC and thermoplastic, zinc coated steel screws and bolts		

# Montage

## Outils nécessaires au montage

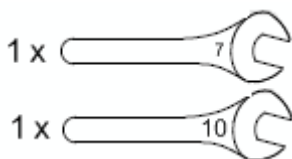

## Règle d'installation 1

Support each transfer element by 2 fixed hangers in accordance with the diagrams below.

## Outils nécessaires au démontage

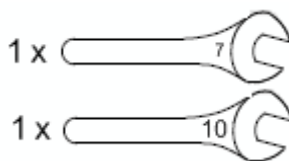

## Image d'installation

### CONSTITUTION D'UNE LIGNE AVEC TROMPETTES COURTES :

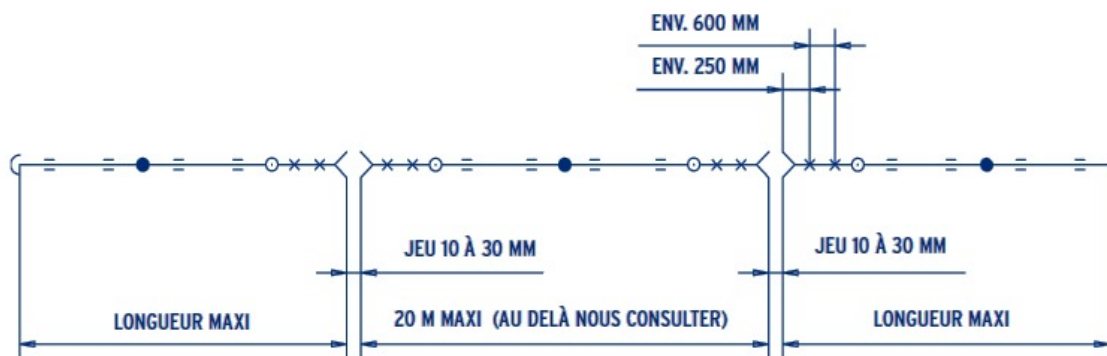

#### Longueur maxi sans joint de dilatation

Tableau valable pour les configurations avec trompette courte ou longue

Calibre	20A	40A	60A	100A	130A	160A	200A
Longueur maximum	62 m	76 m	62 m	52 m	40 m	35 m	30 m

### CONSTITUTION D'UNE LIGNE AVEC TROMPETTES LONGUES :

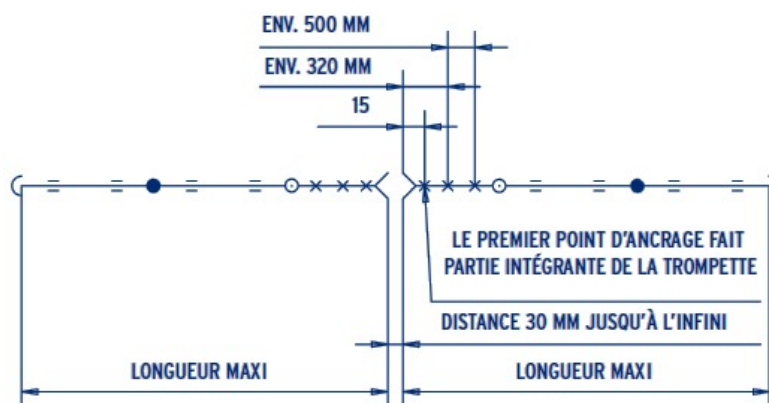

⌋	Capot de fermeture
○	Couvre joint
●	Boîte d'alimentation
=	Suspension coulissante
×	Point d'ancrage
⊕	Terre
<	Élément de transfert

### Règle de montage 1

Align the transfer elements in both planes, within the limits of the following alignment tolerances: max. 3mm for short transfer elements and max. 10mm for long transfer elements. Adjust if need be to get the trolley run smoothly.

### Maintenance

The operating life of the transfer elements and trolleys will be longer if the transfer elements are well aligned and if the trolleys are driven in the axis of the line. For a pair of transfer elements, the trolley should be replaced every 25,000 cycles through and back. After the same number of cycles, or at least once a year, you should check: - the degree of electrical insulation. If necessary clean the cone, after first disconnecting the installation from the mains. - the mechanical condition of the transfer elements and the trolleys (rollers, brushes, signs of wear in the cones etc.).

## Circuit interruption element

Ensures the electrical insulation between 2 sections in the same feeding line.



### Description

The purpose of the circuit interruption element is to insulate electrically one part of the line from another. Example: on a line with several travelling cranes, the circuit interruption element allows maintenance to be carried out on a crane (in a well defined area) while the other cranes continue to run. Selecting the type of circuit interruption element depends on how the line is used. - "safety" interruption: Prevents the insulation from being short-circuited via the trolley. This configuration requires the trolley to be driven manually or mechanically from one sector to the other over the insulation. The circuit interruption element must be adapted to the trolley type (e.g. double interruption for double collector trolley). - "comfort" interruption: In this case, it is possible to short-circuit the insulation via the trolley. This configuration means the trolley can pass automatically from one sector to the other with current continuity if a double or triple collector trolley is used. A single interruption is always appropriate for this configuration (it must be shorter than the trolley). Caution: The customer is responsible for taking the appropriate safety measures to prevent the trolley from short-circuiting the circuit interruption and supplying electricity to the maintenance area. Nota bene: The length "L" of the element should be stated when ordering. In the standard version, the interruption is located at the centre of the element, if you wish it to be placed elsewhere, please provide a drawing defining the position required. In this case, the element is given a special reference. For double or triple interruptions (no current continuity) the insulation area of 140 mm is extended. (412 mm for double interruptions and 684 mm for triple interruptions). The circuit interruption element must in no case be used as an electrical switch. The electrical arcs generated by driving the collector trolley across the interruption damage the conductors and insulators. Check possible reduction in the current capacity of the trolleys due to the insulators. Each section of the circuit must be provided with its own feed box. The earth conductor is continuous. The circuit interruption element is assembled like a standard element. When the maintenance area is cut off from the mains, make sure that no collector trolleys are travelling as they are likely to short-circuit the circuit interruption. The insulation between the conductors on the same pole on either side of the circuit interruption element must be checked regularly, at least once a year.

### Categorie

Standard

### Avantage n°1

Can be fitted as easily as a straight element

### Avantage n°2

Visual location of the interruption position from the outside

## Références et compatibilités

### Références et variantes

Available in standard range and with dust-protecting lips, add '- LV' after the reference.

## Références et variantes

References		20 A	40 A	60 A	100 A	130 A	160 A	200A TR
Single interruption	4 poles	ME1960	ME1962	ME1964	ME1966	ME1968	ME1950	ME1970-TR
	5 poles	ME1961	ME1963	ME1965	ME1967	ME1969	ME1951	ME1971-TR
Double interruption	4 poles	ME1972	ME1974	ME1976	ME1978	ME1980	ME1952	ME1982-TR
	5 poles	ME1973	ME1975	ME1977	ME1979	ME1981	ME1953	ME1983-TR
Triple interruption	4 poles	ME1984	ME1986	ME1988	ME1990	ME1992	ME1954	ME1994-TR
	5 poles	ME1985	ME1987	ME1989	ME1991	ME1993	ME1955	ME1995-TR

Disponible avec lèvres ?	oui	Disponible en version haute température ?	non
Disponible en version sans terre ?	oui	Disponible en version courbe ?	non

## Données techniques

### Données techniques

Maximum line length with circuit interruption element, without expansion joint:

Intensity	20A	40A	60A	100A	130A	160A	200A-TR
Max. length *	140 m	150 m	150 m	150 m	150 m	150 m	150 m

\* when circuit interruption is positionned in the middle of the line

Beyond these lengths an expansion joint is required per section of 100m max.

<b>Poids</b>	identique à l'élément standard équivalent		
<b>Tension d'emploi</b>	750V	<b>Température d'utilisation</b>	-30°C to +55°C
<b>Calibre</b>	20A, 40A, 60A, 100A, 130A, 160A, 200A		
<b>Matière</b>	Self-extinguishing PVC light grey		

## Montage

### Outils nécessaires au montage

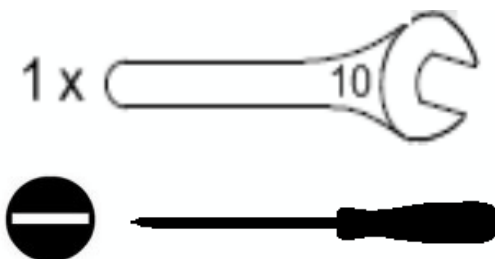

### Outils nécessaires au démontage

### Règle d'installation 1

Elements to be clipped in sliding hangers, connection of the elements end to end by tightening the connections.

### Règle de montage 1

1. Insert the lines in the sliding hangers, 2. Connect the lines

## Maintenance

Regular inspection is required to check the insulation between the conductors of the same pole on both sides of the interruption, at least once a year.



## Rigid trolleys

The collector trolley shunts the electrical current in the Mobilis line to the mobile device requiring power.



### Description

The rigid trolley is designed to shunt the electrical current in standard installations (no curve) operating at speeds up to 100m/min. It is not intended to support a load. It is inserted into the line by matching poles using a system of safety pins. The mechanical link between the trolley and the mobile device is ensured by the carrier. The self-lubricating carbon brushes, mounted on springs, thereby guaranteeing a permanent contact with the conductor. The trolley is available in 3 versions: - Two versions with a box, without cable, cable gland M25, allowing connection via flexible copper cables of 2.5 mm<sup>2</sup> to 6 mm<sup>2</sup>, Ø13 to 19 mm, of Class 5 minimum only, one with a pole identified for earth (standard version), the other without earth location with poles L1 to L5. Third version prewired with earth pole, with cable H07-RNF (4 X 4 mm<sup>2</sup> or 5 X 4 mm<sup>2</sup> or 6 mm<sup>2</sup>). The prewired trolley can be delivered with a cable length of 1m (standard), or more (on request). The carbon brush (or brushes) are the parts of the Mobilis Elite trolley most subject to wear. They can be easily replaced without intervention on wiring. A simple screwdriver is all that is needed. The maximum wear tolerance is etched on the body of the trolley. The single trolley can shunt up to 40 A when travelling. For higher intensities, building a set of 2 to 3 collector trolleys (double collector, triple collector) can respectively shunt up to 80 A and up to 120 A. In installations with dust-protecting lips, only single trolleys should be used.

### Categorie

Standard

### Avantage n°1

Access to connection plate without taking trolley out

### Avantage n°2

Available in version with/and without cable

## Références et compatibilités

### Références et variantes

Rigid trolley up to 100m/min. For the simplified trolleys, high speed, articulated for curves, cleaners and special transfer, refer to the related items. For versions with box outlet without earth marking, add - B after the reference.

## Références et variantes

	Simple rigid trolley		Double rigid trolley		Triple rigid trolley	
Rated current	40A		80A		120A	
Weight (kg)	0,6		1,2		1,8	
Terminal block	6mm <sup>2</sup>		6mm <sup>2</sup>		6mm <sup>2</sup>	
Compatible cables	flexible cables from 2,5 mm <sup>2</sup> to 6 mm <sup>2</sup> , Ø13 to 19 mm					
	4 poles	5 poles	4 poles	5 poles	4 poles	5 poles
With 1m cable 4mm <sup>2</sup> HO7-RNF	ME2043	ME2051	ME4047-1M	ME4051	ME5049-1M	ME5059
With 1m cable 6mm <sup>2</sup> HO7-RNF	ME2046	Consult us	ME4046-1M	Consult us	ME5046	Consult us
Output M25, with earth marking	ME3043	ME3051	ME4042	ME4050	ME5040	ME5050
Output M25, without earth marking	ME3043-B	ME3051-B	ME4042-B	ME4050-B	ME5040-B	ME5050-B

**Disponible en version sans terre ?**

oui

**Disponible en version courbe ?**

see 'articulated trolleys

---

## Données techniques

Authorised conditions of use for stationary application			
Duration	Current simple trolley	Current double trolley	Current triple trolley
40 seconds	40A	80A	120A
5 minutes	30A	60A	90A
30 minutes	20A	40A	60A
≥ 1 hour	16A	32A	48A

	Type of trolley	Value
Speed of mobile	all	100m/min
Duration of micro-cutoff	all	< 3ms*
Micro-cutoffs at 50m/min	simple	< 1ms
Micro-cutoffs at 250m/min	simple	< 3ms
Micro-cutoffs at 250m/min	double	< 1ms
Micro-cutoffs at 250m/min	triple	< 1ms

\*The contact quality changes according to speed but remains under the 3ms prescribed value from the Norm EN60204-32

In order to reduce the risk of micro-cutoffs damaging electronic components, the collector trolley should be doubled or tripled (see related heading)

Warning concerning electrical protection:

Above 3 metres cable length, please refer to norm EN 60204-32 §7.2.8

## Encombrement

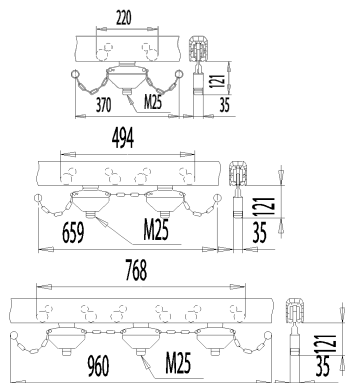

<b>Poids</b>	According to reference		
<b>Calibre du chariot</b>	40A, 80A, 120A	<b>Tension d'emploi</b>	750V
<b>Température d'utilisation</b>	-20°C to +75°C		
<b>Matière</b>	Self-extinguishing thermoplastic, self-lubricating carbon brushes, galvanized steel		

## Fichier 3D à télécharger

[http://catalogue.fels.fr/medias/produits/Chariot\\_double\\_2010\\_06.7z](http://catalogue.fels.fr/medias/produits/Chariot_double_2010_06.7z)

## Montage

### Outils nécessaires au montage



POZIDRIV Z N°1 

### Outils nécessaires au démontage



POZIDRIV Z N°1 

### Règle d'installation 1

Providing an introduction gate allows to remove the trolley for maintenance, see the related section.

### Règle de montage 1

Provide adequate loop of cable so as not to impede the motion of the trolley

## Règle de montage 2

### 8 Chariot collecteur Trolley Stromabnehmerwagen

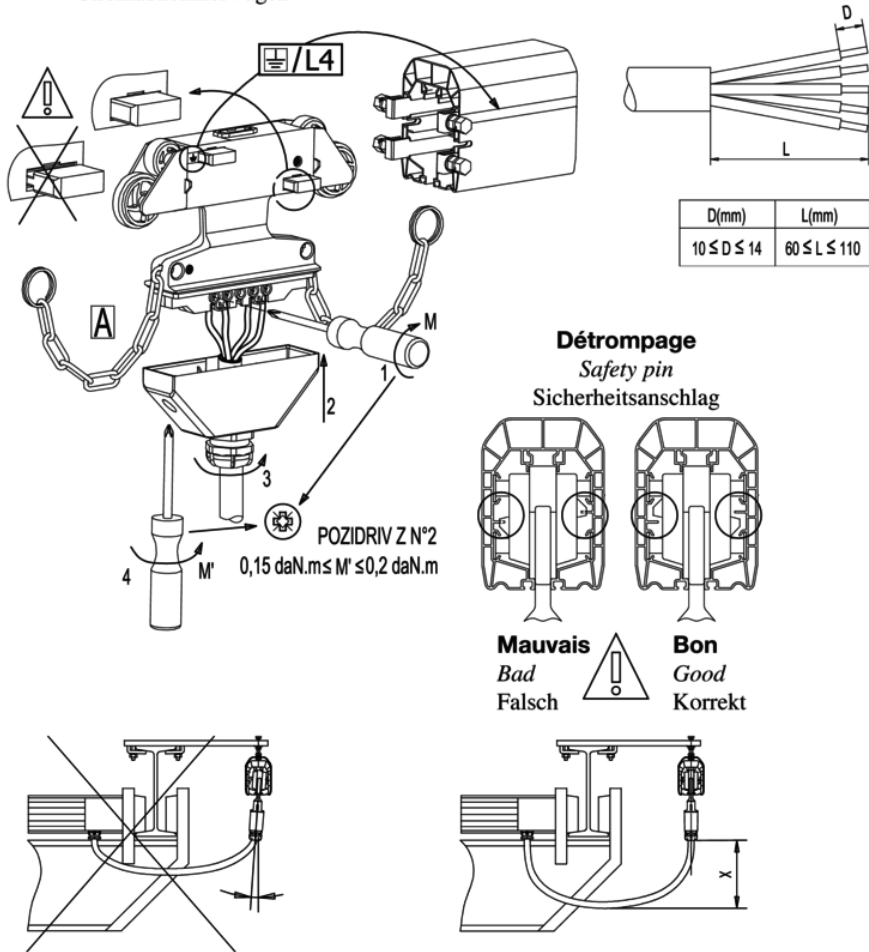

#### Détrompage Safety pin Sicherheitsanschlag

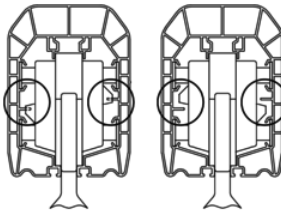

**Mauvais**  
Bad  
Falsch

**Bon**  
Good  
Korrekt

Cable / Cable / Kabel H07 RNF		
	4G4	4G6
X mini	70mm	120mm



**Raccordement : câble souple  $\leq 4 \text{ mm}^2$  préconisé,  $6 \text{ mm}^2$  maxi admis**  
Connecting : flexible cable  $\leq 4 \text{ mm}^2$  recommended,  $6 \text{ mm}^2$  maxi admitted  
Anschluss : flexible Leitung  $\leq 4 \text{ mm}^2$  empfohlen,  $6 \text{ mm}^2$  maximal zulässig

**Avant toute intervention, la ligne doit être mise hors tension**  
Before any interention the line must be switched off  
Vor jedem Eingriff muß die Schleifleitung vom Netz getrennt werden

**La mise en place ou la sortie du chariot se fait normalement à une extrémité de la ligne**  
The driving in or out of the collector trolley must be made at one end of the line  
Der Ein- und Ausbau der Stromabnehmerwagen erfolgt normalerweise an den enden

### Maintenance

Check the wear of the brushes periodically using the wear indicator etched on the body of the trolley. The brushes can be replaced easily with no intervention on wiring required. A simple screwdriver only is necessary. An indicator showing the maximum wear tolerance is etched on the body of the trolley. Check the play and wear of the rollers.

Image maintenance

The diagram illustrates the removal of a terminal block from a rail. It shows a terminal block with pins labeled 1, 2, 3, and 5. A screwdriver is used to remove the terminal block from the rail. The table below provides the dimensions for different current ratings.

	12-20A	40A	60A	100A	130A	160A	200A
Lmini (5)	9,5	10	9,5	9	8	6,5	4,5
Lmini (1,2,3)	8	8,5	8	7,5	6,5	5	3
Lmini (≡)	8	8,5	8	7,5	6,5	7,5	6,5

## Simplified trolleys

The collector trolley shunts the electrical current in the Mobilis line to the mobile device requiring power.

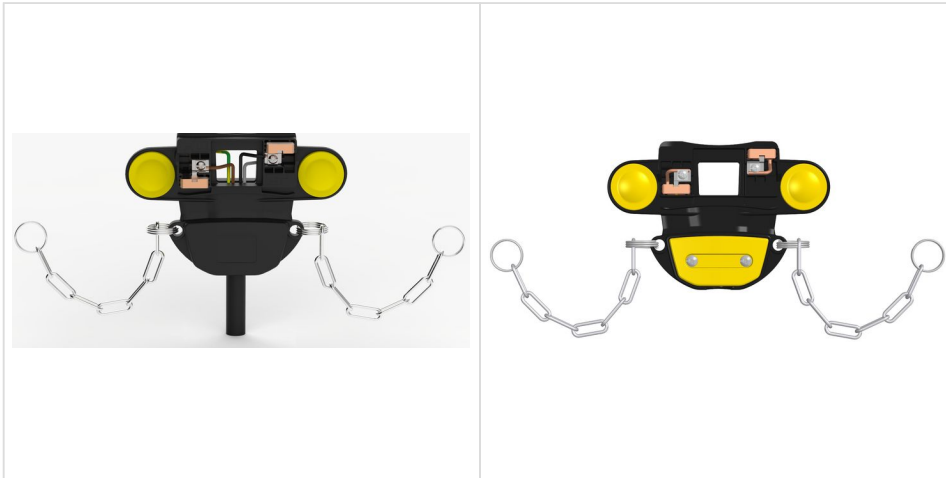

### Description

The simplified trolley is used to shunt the electrical current in standard installations (no curve) operating at speeds up to 70m/min of 4 poles maximum. It is not intended to support a load. It is inserted into the line by matching poles using a system of safety pins. The mechanical link between the trolley and the mobile device is ensured by the carrier. The self-lubricating carbon brushes, mounted on springs, thereby guaranteeing a permanent contact with the conductor. The trolley is available in 2 versions: - One version with a box, without cable, + cable gland M25, allowing connection via flexible copper cables of 2.5 mm<sup>2</sup> to 6 mm<sup>2</sup>, Ø13 to 19 mm, of Class 5 minimum only. And a second version prewired with cable H07-RNF (4 X 4 mm<sup>2</sup> or 6 mm<sup>2</sup>). The prewired trolley can be delivered with a cable length of 1m (standard), or more (on request). The carbon brushes (or brushes) are the parts of the Mobilis Elite trolley most subject to wear. They can be easily replaced without intervention on wiring. A simple screwdriver is all that is needed. The maximum wear tolerance is etched on the body of the trolley. The single trolley can shunt up to 40 A when travelling. For higher intensities, use double or triple rigid collector trolleys.

### Categorie

Standard

### Avantage n°1

Simplified version for low-intensity applications

### Avantage n°2

cost-effective up to max. 40A 4P

## Références et compatibilités

### Références et variantes

The simplified trolleys are available in versions fitted with/without cable H07RNF.

### Références et variantes

Version	Reference	Weight
Without cable	ME 2034	0,7kg
With 1 m cable 4mm <sup>2</sup>	ME 2034-1M	1,1kg
With 1 m cable 6mm <sup>2</sup>	ME 2036	1,2kg

## Données techniques

### Données techniques

Authorized conditions of use for stationary application	
Duration	Current
40 seconds	40A
5 minutes	30A
30 minutes	20A
≥ 1 hour	16A

Speed of simplified trolleys	
Maximum speed of mobile	70m/min
Duration of micro-cutoffs *	< 3ms

\* The duration of micro-cutoffs are less than the maximum recommended by the norm EN 60204-32 (3ms)

In order to reduce the risk of micro-cutoffs damaging electronic components, the collector trolley should be doubled or tripled (see related heading)

Warning concerning electrical protection:  
Above 3 metres cable length, please refer to norm EN 60204-32 §7.2.8



## Encombrement

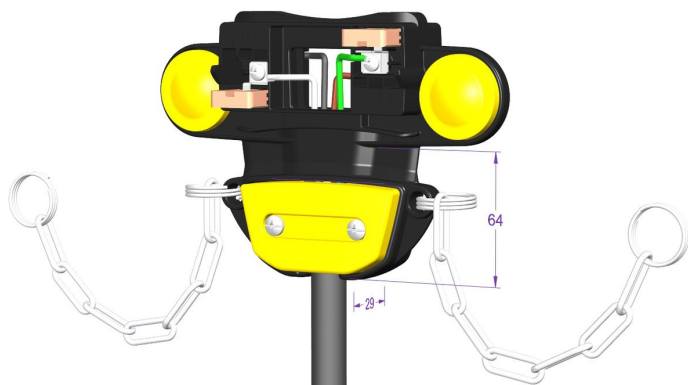

**Encombrement L x H x Z**

29 x 64 x 193

**Poids**

According to reference

**Calibre du chariot**

40A

**Tension d'emploi**

750V

**Température d'utilisation**

-20°C to +55°C

**Matière**

Self-extinguishing thermoplastic, self-lubricating carbon brushes, galvanized steel

---

## Montage

**Outils nécessaires au montage**



**Outils nécessaires au démontage**



**Règle d'installation 1**

Providing an introduction gate allows to remove the trolley for maintenance, see the related section.

**Règle de montage 1**

Provide adequate loop of cable so as not to impede the motion of the trolley

## Règle de montage 2

### 8 Chariot collecteur

Trolley

Stromabnehmerwagen

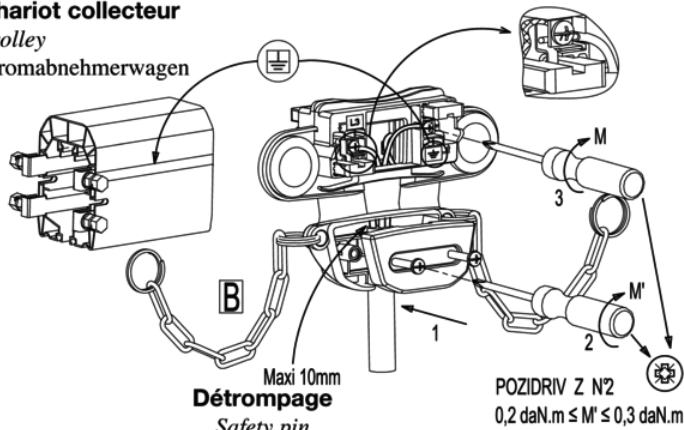

Maxi 10mm  
**Détrompage**

Safety pin

Sicherheitsanschlag

POZIDRIV Z N°2  
0,2 daN.m ≤ M' ≤ 0,3 daN.m

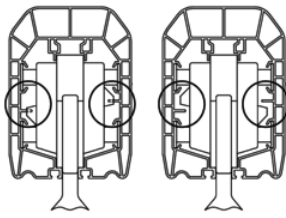

**Mauvais**

Bad  
Falsch



**Bon**

Good  
Korrekt

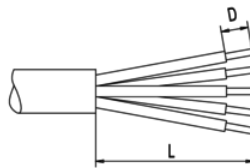

D(mm)	L(mm)
15	95 ≤ L ≤ 100

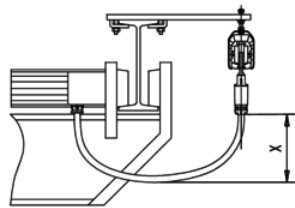
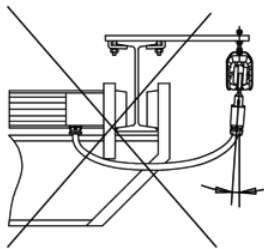

**Cable / Cable / Kabel H07 RNF**

	4G4	4G6
X mini	70mm	120mm



**Raccordement : câble souple ≤ 4 mm<sup>2</sup> préconisé, 6 mm<sup>2</sup> maxi admis**

Connecting : flexible cable ≤ 4 mm<sup>2</sup> recommended, 6 mm<sup>2</sup> maxi admitted

Anschluss : flexible Leitung ≤ 4 mm<sup>2</sup> empfohlen, 6 mm<sup>2</sup> maximal zulässig

**Avant toute intervention, la ligne doit être mise hors tension**

Before any interention the line must be switched off

Vor jedem Eingriff muß die Schleifleitung vom Netz getrennt werden

**La mise en place ou la sortie du chariot se fait normalement à une extrémité de la ligne**

The driving in or out of the collector trolley must be made at one end of the line

Der Ein- und Ausbau der Stromabnehmerwagen erfolgt normalerweise an den enden

## Maintenance

Check the wear of the brushes and the general state of the trolley periodically

## Articulated trolley

The articulated trolley is for installations with horizontal curves (whatever the radius).



### Description

Articulated trolley must be used to shunt the electrical current in all installations including curves with maximum speed limit of 70m/min. They are not intended to support a load. An articulated trolley is inserted into the line by matching poles using a system of safety pins. The mechanical link between the trolley and the mobile device is ensured by the carrier. The self-lubricating carbon brushes, are mounted on springs, thereby guaranteeing a permanent contact with the conductor. The trolley is available in in 3 versions: - Two versions with a box, without cable, + cable gland M25, allowing connection via flexible copper cables of 2.5 mm<sup>2</sup> to 6 mm<sup>2</sup>, Ø13 to 19 mm, of Class 5 minimum only, one with a pole identified for earth (standard version), the other without earth location with poles L1 to L5. Third version prewired with earth pole, with cable H07-RNF (4 X 4 mm<sup>2</sup> or 5 X 4 mm<sup>2</sup> or 6 mm<sup>2</sup>). The prewired trolley can be delivered with a cable length of 1m (standard), or more (on request). The carbon brush (or brushes) are the parts of the Mobilis Elite trolley most subject to wear. They can be easily replaced without intervention on wiring. A simple screwdriver is all that is needed. The maximum wear tolerance is etched on the body of the trolley. The single trolley can shunt up to 40 A when travelling. For higher intensities, building a set of 2 to 3 collector trolleys (double collector, triple collector) can respectively shunt up to 80 A and up to 120 A. In installations with dust-protecting lips, only single trolleys should be used.

### Categorie

Curves

### Avantage n°1

Suitable for installations with curves

### Avantage n°2

Access to connection plate without taking trolley out

---

## Références et compatibilités

### Références et variantes

Trolley references for installation with horizontal curve according to the following table.

## Références et variantes

	Simple articulated trolley		Double articulated trolley		Triple articulated trolley	
Rated current	40A		80A		120A	
Weight (kg)	0,9kg		1,1kg		1,6kg	
Terminal block	6mm <sup>2</sup>		6mm <sup>2</sup>		6mm <sup>2</sup>	
Compatible cables	flexible cables from 2,5 mm <sup>2</sup> to 6 mm <sup>2</sup> , Ø13 to 19 mm					
	4 poles	5 poles	4 poles	5 poles	4 poles	5 poles
Compatible carrier with box	ME1660		ME1640	ME1645	ME1650	ME1655
With 1m cable 4mm <sup>2</sup> HO7-RNF	ME2042	ME2050	ME4040	ME4055	ME5041	ME5055
Without cable	ME3042	ME3050	ME4041	ME4052	ME5042	ME5052
Without earth marking, without cable	ME3042-B	ME3050-B	ME4041-B	ME4052-B	ME5042-B	ME5052-B

Disponible en version sans terre ?

oui

---

## Données techniques

## Données techniques

Authorised conditions of use for stationary application			
Duration	Current simple trolley	Current double trolley	Current triple trolley
40 seconds	40A	80A	120A
5 minutes	30A	60A	90A
30 minutes	20A	40A	60A
≥ 1 hour	16A	32A	48A

	Type of trolley	Value
Speed of mobile in a straight line	tous	100m/min
Speed of mobile in a curve *	tous	70m/min
Duration of micro-cutoffs	tous	< 3ms**
Cutoffs at 50m/min	simple	< 1ms
Cutoffs at 250m/min	simple	< 3ms
Cutoffs at 250m/min	double	< 1ms
Cutoffs at 250m/min	triple	< 1ms

\* Speed must be reduced in case of sharp curves

\*\* The contact quality changes according to speed but remains under the 3ms prescribed value from the Norm EN60204-32

In order to reduce the risk of micro-cutoffs damaging electronic components, the collector trolley should be doubled or tripled (see related heading)

### Warning concerning electrical protection:

Above 3 metres cable length, please refer to norm EN 60204-32 §7.2.8  
se référer à la norme EN 60204-32 §7.2.8

<b>Encombrement L x H x Z</b>	35 x x 251		
<b>Poids</b>	According to reference		
<b>Calibre du chariot</b>	40A, 80A, 120A	<b>Tension d'emploi</b>	750V
<b>Température d'utilisation</b>	-20°C to +75°C		
<b>Matière</b>	Self-extinguishing thermoplastic, self-lubricating carbon brushes		

---

# Montage

## Outils nécessaires au montage



## Outils nécessaires au démontage



## Règle d'installation 1

For satisfactory operation, check the position of the trolleys when carried in the curved sections, including when the position of the current taker is shifted in relation to the mobile device, and limit offsetting to a maximum of 50mm.

## Règle de montage 1

Adjust the position of the trainer to cross over junctions smoothly.

## Règle de montage 2

### 8 Chariot collecteur Trolley Stromabnehmerwagen

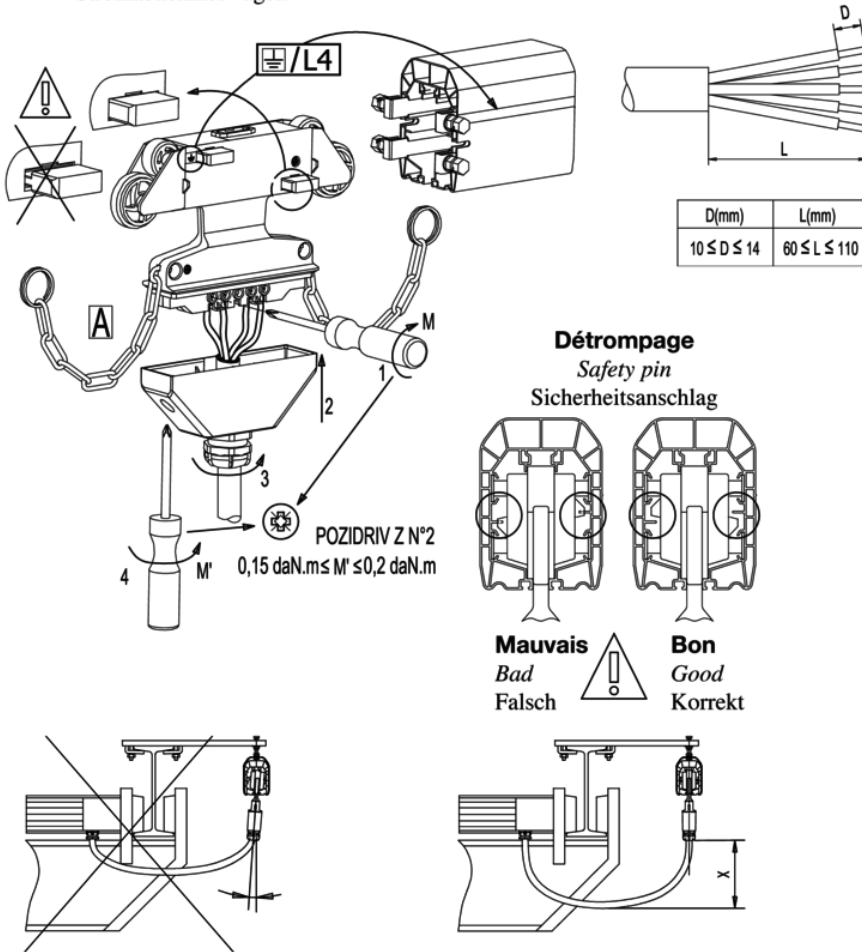

D(mm)	L(mm)
10 ≤ D ≤ 14	60 ≤ L ≤ 110

#### Détrompage Safety pin Sicherheitsanschlag

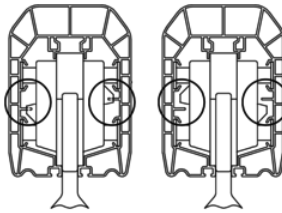

**Mauvais**  
Bad  
Falsch

**Bon**  
Good  
Korrekt

#### Cable / Cable / Kabel H07 RNF

	4G4	4G6
X mini	70mm	120mm



**Raccordement : câble souple ≤ 4 mm<sup>2</sup> préconisé, 6 mm<sup>2</sup> maxi admis**  
Connecting : flexible cable ≤ 4 mm<sup>2</sup> recommended, 6 mm<sup>2</sup> maxi admitted  
Anschluss : flexible Leitung ≤ 4 mm<sup>2</sup> empfohlen, 6 mm<sup>2</sup> maximal zulässig

**Avant toute intervention, la ligne doit être mise hors tension**  
Before any interention the line must be switched off  
Vor jedem Eingriff muß die Schleifleitung vom Netz getrennt werden

**La mise en place ou la sortie du chariot se fait normalement à une extrémité de la ligne**  
The driving in or out of the collector trolley must be made at one end of the line  
Der Ein- und Ausbau der Stromabnehmerwagen erfolgt normalerweise an den enden

### Maintenance

Check the wear of the brushes periodically using the wear indicator etched on the body of the trolley. The brushes can be replaced easily with no intervention on wiring required. A simple screwdriver only is necessary. An indicator showing the maximum wear tolerance is etched on the body of the trolley. Check the play and the wear of the rollers.

## Special trolley for transfer element

To ensure continuity of electrical supply in the transfers and guiding of trolley for crossing transfer elements.

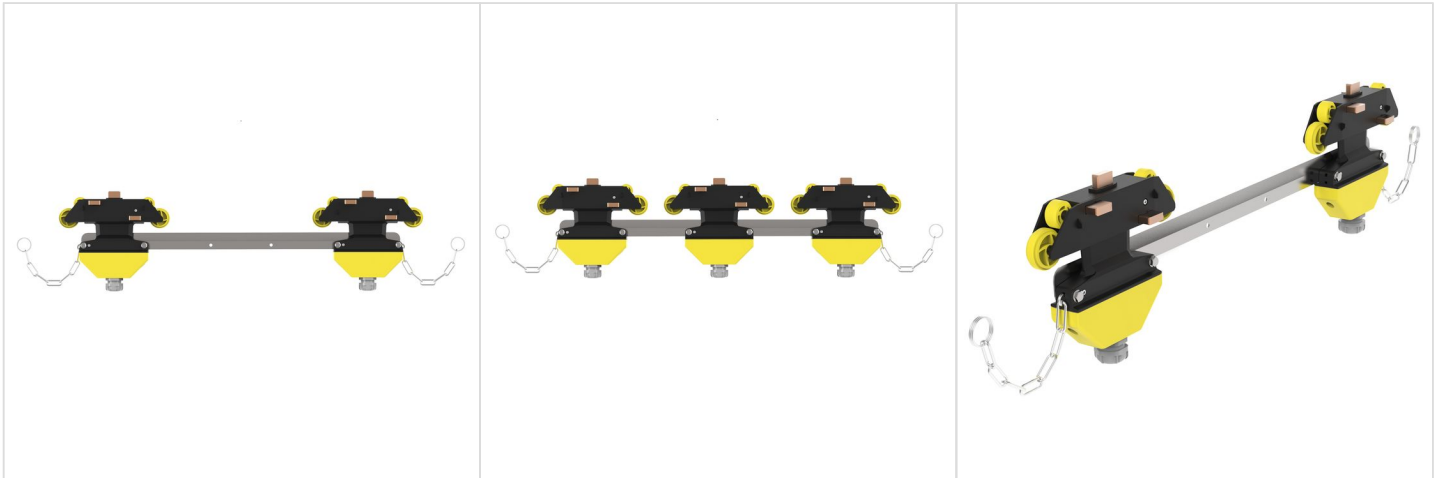

### Description

Caution: Operator protection against access to the live brushes on the trolley when crossing the clearance between transfer elements must be provided by the customer. The dead length, made up of the cones of the transfer elements and the insulators, requires the use of sets of specially designed trolleys and carriers. Trolley for short transfer element: With transfer elements with a short cone, double or triple trolleys with a coupling bar should be used together with a triple carrier with box type ME1650 (4 poles) or ME1655 (5 poles) to ensure current continuity. Trolley for long transfer element: Use standard single trolleys (rigid or articulated as appropriate) and double and triple coupled trolleys. In the clearance between the transfer elements, the trolleys must be maintained in the air. It is imperative to use a special carrier reference ME1680. In the standard version, cable 1 metre long only. The special trolley for transfer element is used to shunt the electrical current in installations with short or long transfer elements. The max. speed when crossing the transfer elements is 70m/min. Apart from the transfer elements, speed up to 100m/min with rigid or articulated trolleys, 180m/min with high speed trolleys. The special trolley for transfer element is not intended to support a load. It is inserted into the line by matching poles using a system of safety pins. The mechanical link between the trolley and the mobile device is ensured by the carrier. The self-lubricating carbon brushes, are mounted on springs, thereby guaranteeing a permanent contact with the conductor. The carbon brush (or brushes) are the parts of the Mobilis Elite trolley most subject to wear. They can be easily replaced without intervention on wiring. A simple screwdriver is all that is needed. The maximum wear tolerance is etched on the body of the trolley. The single trolley can shunt up to 40 A when travelling. For higher intensities, building a set of 2 to 3 collector trolleys (double collector, triple collector) can respectively shunt up to 80 A and up to 120 A.

### Categorie

Transfer

### Avantage n°1

Current continuity in the transfers with short transfer elements

### Avantage n°2

Suitable for transfers

## Références et compatibilités

### Références et variantes

The following references apply to the trolleys for transfer with 1-metre cable outlet.



## Références et variantes

Reference	Double trolley for transfer element		Triple trolley for transfer element		Length L
	4 poles	5 poles	4 poles	5 poles	
Rigid	ME4060	ME4070	ME5060	ME5070	725mm
Articulated	ME4062	ME4072	ME5062	ME5072	756mm
High speed	ME4065	ME4075	ME5065	ME5075	783mm
Weight	2,0 kg		2,8kg		

Disponible en version sans terre ?

oui

Disponible en version courbe ?

oui

## Données techniques

### Données techniques

Feeding is continuous in the case of transfer between short transfer elements with maximum space between them of 30mm, and discontinuous in other cases. Please refer to the section on transfer elements to learn about the dead lengths.

### Encombrement

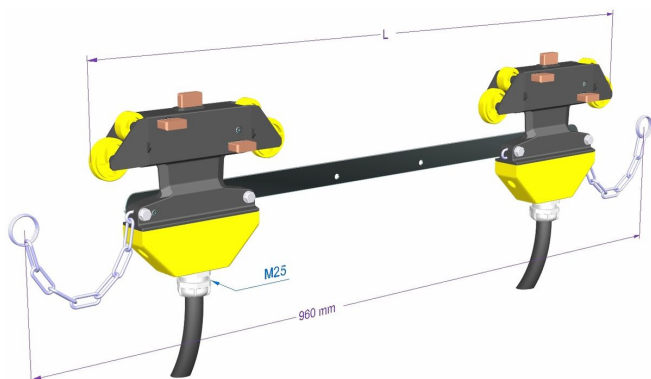

**Encombrement L x H x Z**

35 x 121 x 960

**Poids**

According to reference

**Calibre du chariot**

Trolleys 80A, 120A, with reduced intensity in transfert up to 40A

**Tension d'emploi**

750V

**Température d'utilisation**

-30°C to +75°C

**Matière**

Self-extinguishing thermoplastic, self-lubricating carbon brushes, galvanized steel

## Montage

### Outils nécessaires au montage



**Outils nécessaires au démontage**



POZIDRIV Z N°1 

## Règle d'installation 1

To be used imperatively with transfer elements, or if double or triple trolleys are needed with long transfer elements.

## Règle de montage 1

1. Clip-on the trolley in the line following the direction of the earth pole. 2. Associate the trolley to the trainer. 3. Make sure the transfer elements are well aligned before any translation motion occurs. 4. Make sure there is no excessive mechanical tension due to the adjustment of the carrier or to the traction of the cables.

## Règle de montage 2

### 8 Chariot collecteur Trolley Stromabnehmerwagen

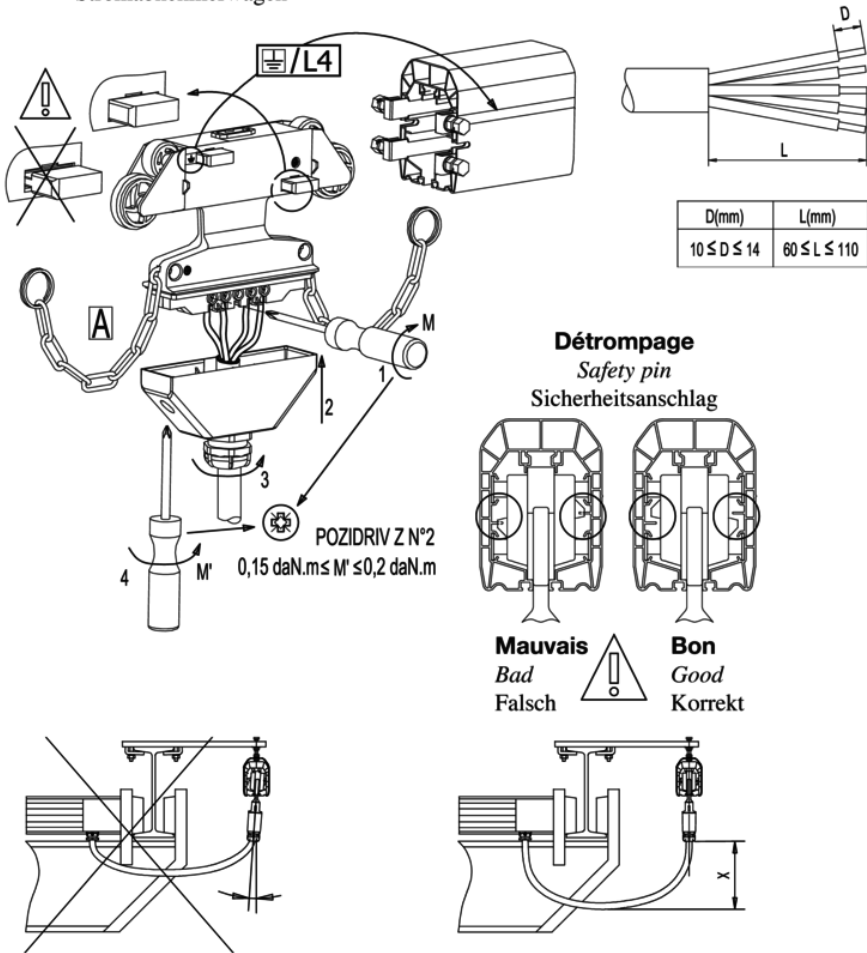

**Raccordement : câble souple ≤ 4 mm<sup>2</sup> préconisé, 6 mm<sup>2</sup> maxi admis**  
*Connecting : flexible cable ≤ 4 mm<sup>2</sup> recommended, 6 mm<sup>2</sup> maxi admitted*  
 Anschluss : flexible Leitung ≤ 4 mm<sup>2</sup> empfohlen, 6 mm<sup>2</sup> maximal zulässig

**Avant toute intervention, la ligne doit être mise hors tension**  
*Before any interention the line must be switched off*  
 Vor jedem Eingriff muß die Schleifleitung vom Netz getrennt werden

**La mise en place ou la sortie du chariot se fait normalement à une extrémité de la ligne**  
*The driving in or out of the collector trolley must be made at one end of the line*  
 Der Ein- und Ausbau der Stromabnehmerwagen erfolgt normalerweise an den enden

## Maintenance

Check the wear of the brushes periodically using the wear indicator etched on the body of the trolley. The brushes can be replaced easily with no intervention on wiring required. A simple screwdriver only is necessary. An indicator showing the maximum wear tolerance is etched on the body of the trolley. Check the play and the wear of the rollers.

## High speed trolley

The high speed trolley shunts the electrical current in the Mobilis line to the mobile device requiring power for speeds > 100m/min.

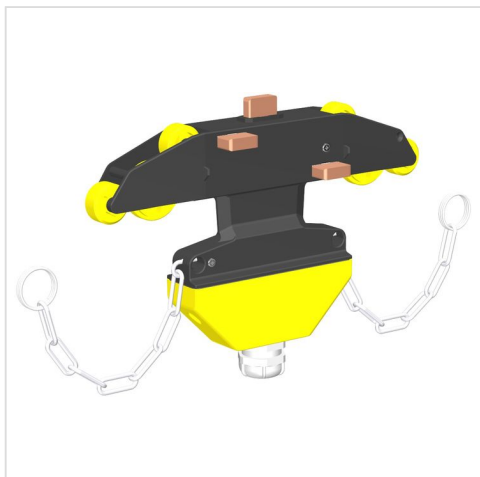

### Description

High speed trolleys have extra rollers to cross over junctions smoothly, even when travelling at high speeds or in very cold weather conditions. High speed trolleys are required for speeds greater than 100 m/min. It is strongly recommended for temperatures below -20°C. All other features of high speed trolleys (excepting running speed and overall dimensions) are identical to those of the rigid trolleys. Version without cable allowing connection via flexible copper cables of 2.5 mm<sup>2</sup> to 6 mm<sup>2</sup>, Ø13 to 19 mm, of Class 5 minimum only. Notice: the triple high speed trolleys are not compatible with the triple carriers. Build a specific carrier or combine single and/or double trolleys with simple and/or double carriers.

### Categorie

Standard

### Avantage n°1

Suitable for speeds up to 180m/min

### Avantage n°2

Quality of contact preserved at high speed

---

## Références et compatibilités

### Références et variantes

References: All high speed trolleys are supplied without cable, please refer to the following list of references.

## Références et variantes

	Simple rigid trolley		Double rigid trolley		Triple rigid trolley	
Nominal current *	40A		80A		120A	
Weight (kg)	0,9		1,1		1,6	
Terminal block	6mm <sup>2</sup>		6mm <sup>2</sup>		6mm <sup>2</sup>	
Compatible cables	flexible cables from 2,5 mm <sup>2</sup> to 6 mm <sup>2</sup> , Ø13 to 19 mm					
	4 poles	5 poles	4 poles	5 poles	4 poles	5 poles
M25 output with earth marking	ME3041	ME3091	ME4043	ME4053	ME5043	ME5053
M25 output without earth marking	ME3041-B	ME3091-B	ME4043-B	ME4053-B	ME5043-B	ME5053-B

\* Check into technical data about currents for stationary application when appropriate

Disponible en version sans terre ?

oui

Disponible en version courbe ?

non

## Données techniques

Authorised conditions of use for stationary application			
Duration	Current simple trolley	Current double trolley	Current triple trolley
40 seconds	40A	80A	120A
5 minutes	30A	60A	90A
30 minutes	20A	40A	60A
≥ 1 hour	16A	32A	48A

	Type of trolley	Value
Speed of mobile	all	180m/min
Duration of micro-cutoff	all	< 3ms*
Micro-cutoffs at 50m/min	simple	< 1ms
Micro-cutoffs at 250m/min	simple	< 3ms
Micro-cutoffs at 250m/min	double	< 1ms
Micro-cutoffs at 250m/min	triple	< 1ms

\* The contact quality changes according to speed but remains under the 3ms prescribed value from the Norm EN60204-32

In order to reduce the risk of micro-cutoffs damaging electronic components, the collector trolley should be doubled or tripled (see related heading)

Warning concerning electrical protection:

Above 3 metres cable length, refer to norm EN 60204-32 §7.2.8

## Encombrement

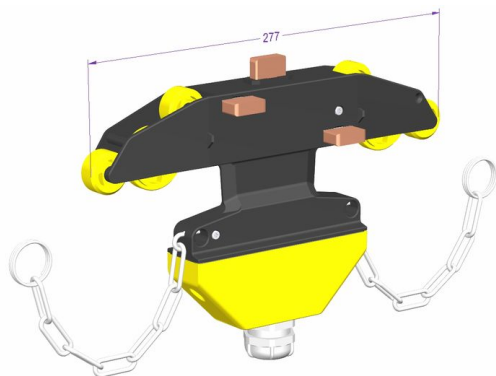

<b>Encombrement L x H x Z</b>	35 x x 277	<b>Poids</b>	1 kg
<b>Calibre du chariot</b>	40A, 80A, 120A	<b>Tension d'emploi</b>	750V
<b>Température d'utilisation</b>	-30°C to +75°C		
<b>Matière</b>	Self-extinguishing thermoplastic, self-lubricating carbon brushes, galvanized steel		

## Montage

### Outils nécessaires au montage



### Outils nécessaires au démontage



### Règle d'installation 1

Providing an introduction gate allows to take out the trolley for maintenance, see the related section. The triple high speed trolleys are not compatible with the triple carriers, use a double carrier and a simple carrier.

### Règle de montage 1

Provide adequate loop of cable so as not to impede the motion of the trolley

## Règle de montage 2

### 8 Chariot collecteur Trolley Stromabnehmerwagen

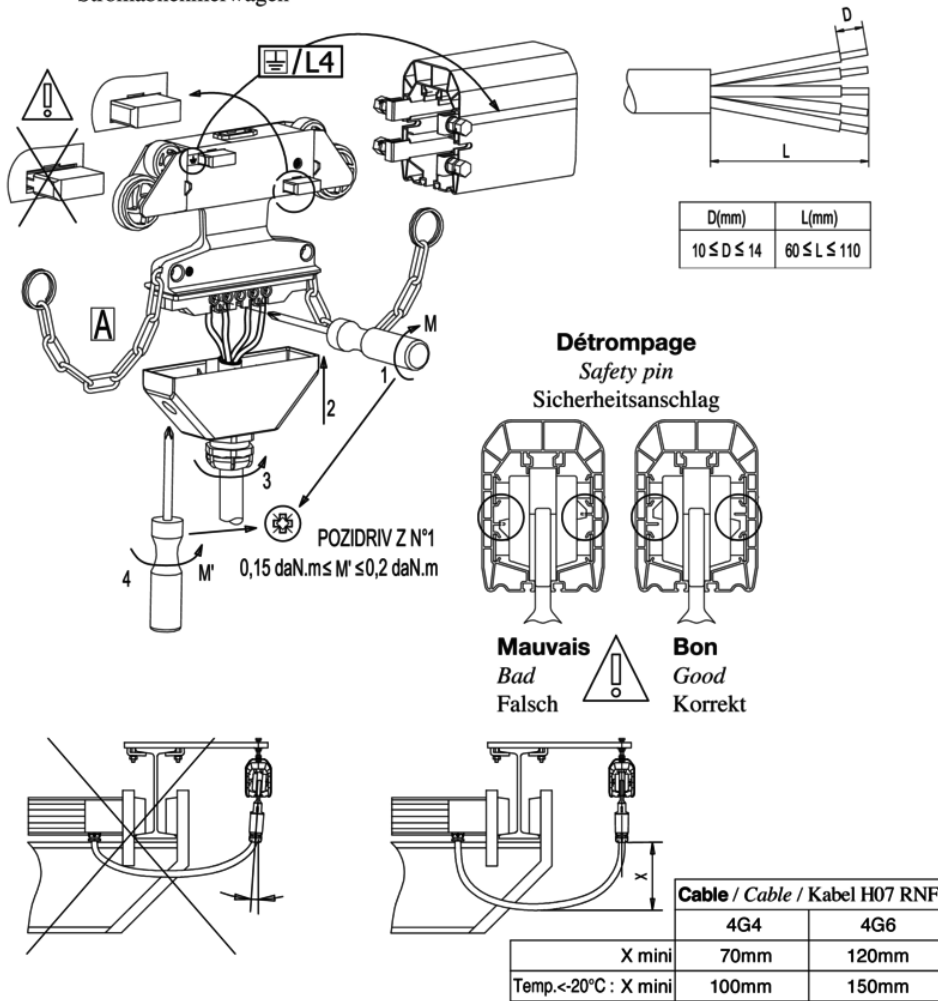

**Raccordement : câble souple ≤ 4 mm<sup>2</sup> préconisé, 6 mm<sup>2</sup> maxi admis**  
*Connecting : flexible cable ≤ 4 mm<sup>2</sup> recommended, 6 mm<sup>2</sup> maxi admitted*  
 Anschluss : flexible Leitung ≤ 4 mm<sup>2</sup> empfohlen, 6 mm<sup>2</sup> maximal zulässig

**Avant toute intervention, la ligne doit être mise hors tension**  
*Before any interention the line must be switched off*  
 Vor jedem Eingriff muß die Schleifleitung vom Netz getrennt werden

**La mise en place ou la sortie du chariot se fait normalement à une extrémité de la ligne**  
*The driving in or out of the collector trolley must be made at one end of the line*  
 Der Ein- und Ausbau der Stromabnehmerwagen erfolgt normalerweise an den enden

### Maintenance

Check the wear of the brushes periodically using the wear indicator etched on the body of the trolley. The brushes can be replaced easily with no intervention on wiring required. A simple screwdriver only is necessary. An indicator showing the maximum wear tolerance is etched on the body of the trolley. Check the play and the wear of the rollers.



## Cleaning trolley

The cleaning trolley is designed to clean the conductors.



### Description

Maintenance accessory used for the renovation of the conductors operating in a dusty environment, very humid environment, slight surface roughness of the conductors, projection of particles towards the line... The frequency of use of the cleaning trolley depends on the application. Caution: the cleaning trolley brushes wear more rapidly than the collector brushes. Do not couple permanently.

### Categorie

Standard

### Avantage n°1

Restores contact quality

### Avantage n°2

Removes pollution on the conductors

## Références et compatibilités

### Références et variantes

The trolley references are related to the features of your installation: 4 or 5 poles and articulated if a curve is included in the installation.

### Références et variantes

Reference	rigid	articulated
4 poles	ME4514	ME4522
5 poles	ME4525	ME4523

Disponible en version courbe ?

oui

# Données techniques

## Données techniques

Designed to be used in the live rail. Replaceable brass scrubbing brushes - set of 5 brushes Ref. ME1356. Cannot shunt current. Driven by simple carrier. Max. travel speed 100m/min.

## Encombrement

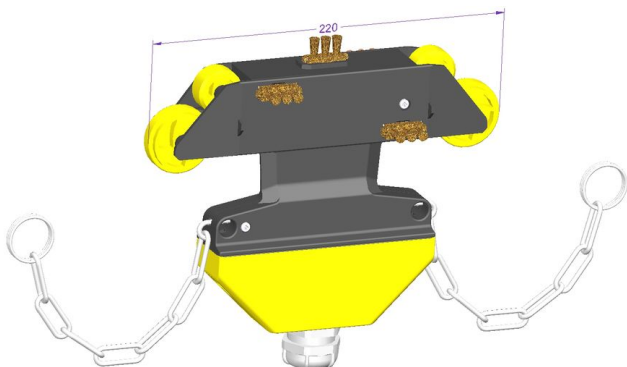

### Encombrement L x H x Z

35 x 165 x L - ME4514 : L=220 / ME4522 : L=251

### Poids

0,4 kg

### Tension d'emploi

750V

### Température d'utilisation

-30°C to +75°C

### Matière

Self-extinguishing thermoplastic, brasswire brushes, galvanized steel

# Montage

## Outils nécessaires au montage



## Outils nécessaires au démontage



## Règle d'installation 1

To be inserted into the line after cut-off from the mains. The cleaning trolley is not intended to be coupled with the collector trolleys and must normally be operated separately to prevent premature wearing of the scrubbing brushes. Run back and forth several times until the surface of the conductors are restored.

## Règle de montage 1

Fit into the line in either direction of assembling. Move by hand, using a cord, or coupled with the mobile device via a simple carrier ME1600.

## Maintenance

Checking and replacing the scrubbing brushes regularly guarantees their effectiveness. Reference of the sets of replacement brushes: ME1356.

## Standard carrier

Element of mechanical link connection between the collector trolley and the mobile device requiring power.

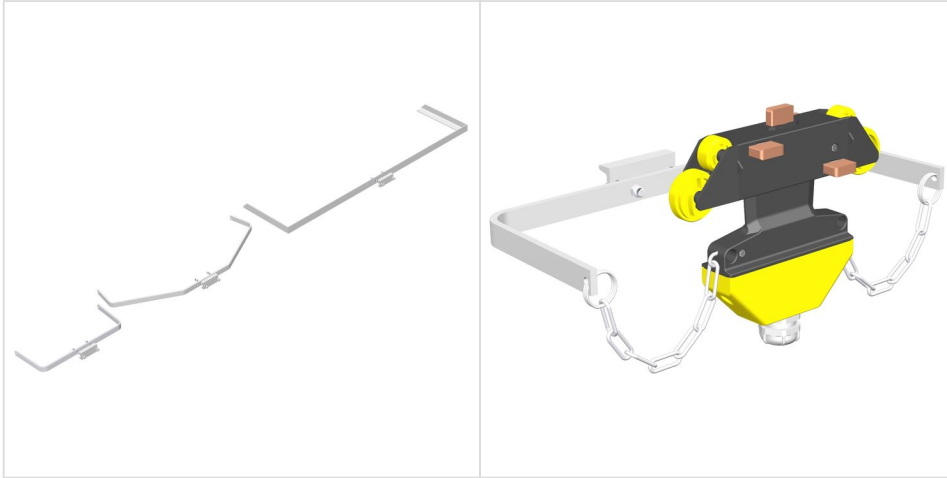

### Description

The standard carriers ensure the mechanical link between the collector trolley which travels inside the Mobilis Elite line and the mobile device requiring current. The triple carriers are not compatible with the triple high speed trolleys.

### Categorie

Standard

### Avantage n°1

Large clearance

### Avantage n°2

For driving squares 20 to 50mm

---

## Références et compatibilités

### Références et variantes

The references are as follows:

Carrier	Simple	Double	Triple
Reference	ME1600	ME1610	ME1630
Trolley compatibility	40A and cleaner	80A	120A except high speed
Footprint H	20 mm	20 mm	30 mm
Footprint L	370 mm	702 mm	1003 mm
Footprint P	160 mm	245 mm	266 mm
Permissible vertical clearance	+0 /-50mm	+0 /-50mm	+0 /-50mm
Permissible horizontal clearance	± 50 mm	± 50 mm	± 50 mm
Weight	0,6kg	1,1kg	2,6kg

Disponible avec lèvres ?

Simple carrier compatible

Disponible en version courbe ?

compatible

## Données techniques

Données techniques

see References

Encombrement

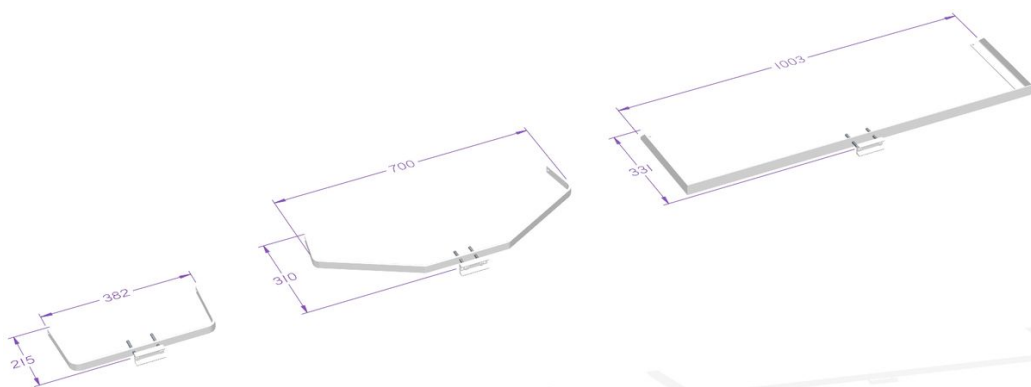

Poids

According to reference

Température d'utilisation

-30°C to +75°C

Matière

Zinc coated steel

# Montage

## Outils nécessaires au montage

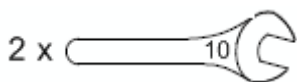

## Outils nécessaires au démontage

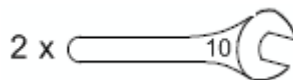

### Règle d'installation 1

Check that the space required for the carrier is available all along the line.

### Règle de montage 1

Adjust in the vertical plane to have the chain of traction of the trolley horizontal or tended downwards (max. -50mm). In the horizontal plane, the chain of the trolley must be in the axis of the line +/- 50mm. Correct adjustment increases the operating life of the trolley collector.

### Règle de montage 2

## 13 Entraîneur / Drivers / Mitnehmer

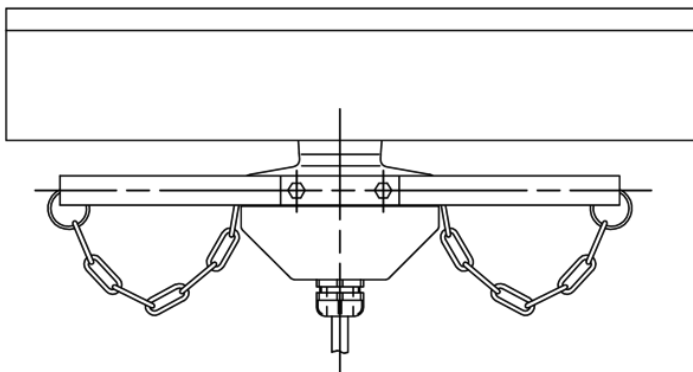

**Si élément courbe, voir notice SPMO 064**  
*If curve element, see instruction SPMO 064*  
Wenn Kurven Element, siehe Anleitungen nach SPMO 064



**La durée de vie des chariots diminue avec l'augmentation du décalage de l'entraînement**  
*More the driving in the axle is displaced, more the life time of the collector decreases*  
Je grösser die Mitnahme des Stromwagens von der Achse versetzt ist, desto vermindert sich die Stromwagenslebensdauer

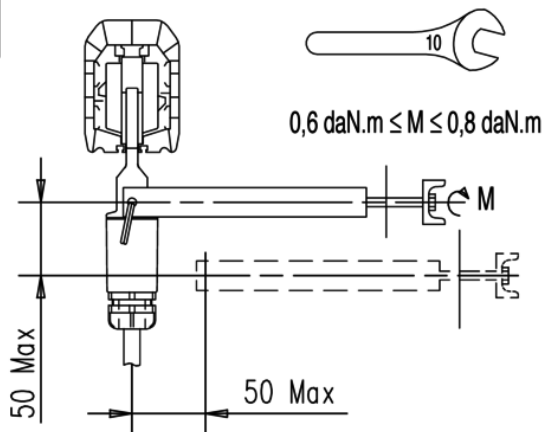

## Maintenance

This element does not require any special maintenance.

## Carrier with box

Element of mechanical link and electrical connection between the collector trolley and the mobile device requiring power.



### Description

The carriers with box ensure the mechanical link between the collector trolley which travels inside the Mobilis Elite line and the mobile device requiring current. They also provide an intermediary connection point between the collector(s) carried and the supply cable of the mobile device.

### Categorie

Standard

### Avantage n°1

Box with intermediate terminal between the trolleys and the mobile device requiring power

### Avantage n°2

For driving squares 20 to 50mm

---

## Références et compatibilités

### Références et variantes

The following references related to the carriers usually supplied according to the trolleys to be carried. The triple carrier with box is not suitable for currents above 100A.

## Références et variantes

Carrier		Simple	Double	Triple
Reference	4 poles	ME1660	ME1640	ME1650
	5 poles		ME1645	ME1655
Trolley compatibility		40A	80A	120A except high speed
Maximum duty cycle factor to 35°C		100%	61%	40%
Maximum duty cycle factor to 55°C		64%	27%	13%
Output cable gland (to box)		1 x M40		
Diameter of output permissible cable		Ø21 - 32 mm		
Input cable gland (to trolley)		1 x M25	2 x M25	3 x M25
Diameter of input permissible cables		Ø13 - 19 mm		
Cable connection		up to 5x16mm <sup>2</sup>	up to 4x25mm <sup>2</sup> or 5x16mm <sup>2</sup>	
Footprint H		20 mm	20 mm	30 mm
Footprint L		370 mm	702 mm	1003 mm
Footprint P		160 mm	245 mm	266 mm
Permissible vertical clearance		+0 /-50mm		
Permissible horizontal clearance		± 50 mm		
Weight		1,4kg	1,9kg	3,4kg

Disponible avec lèvres ?

Simple carrier compatible

Disponible en version sans terre ?

compatible

Disponible en version courbe ?

compatible

## Données techniques

Données techniques

see References



## Encombrement

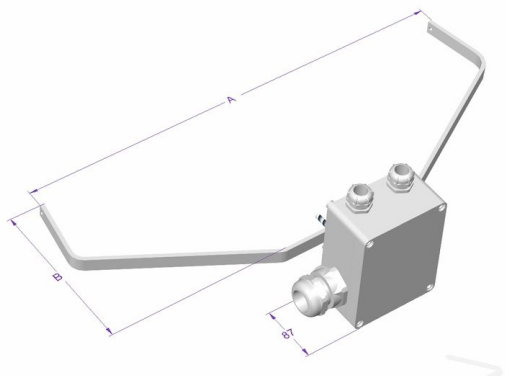

<b>Poids</b>	According to reference	<b>Température d'utilisation</b>	-30°C to +60°C
<b>Tension d'emploi</b>	750V		
<b>Matière</b>	Zinc coated steel and ABS		

## Montage

### Outils nécessaires au montage

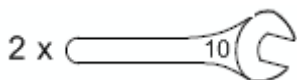

### Outils nécessaires au démontage

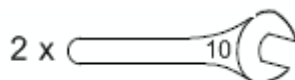

### Règle d'installation 1

Check that the space required for the carrier is available all along the line.

### Règle de montage 1

Adjust in the vertical plane to have the chain of traction of the trolley horizontal or tended downwards (max. -50mm). In the horizontal plane, the chain of the trolley must be in the axis of the line +/- 50mm. Correct adjustment increases the operating life of the trolley collector.

**13** **Entraîneur / Drivers / Mitnehmer**

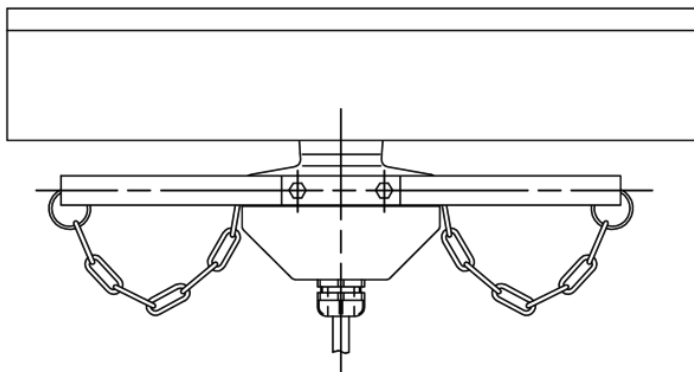

**Si élément courbe, voir notice SPMO 064**  
*If curve element, see instruction SPMO 064*  
Wenn Kurven Element, siehe Anleitungen nach SPMO 064

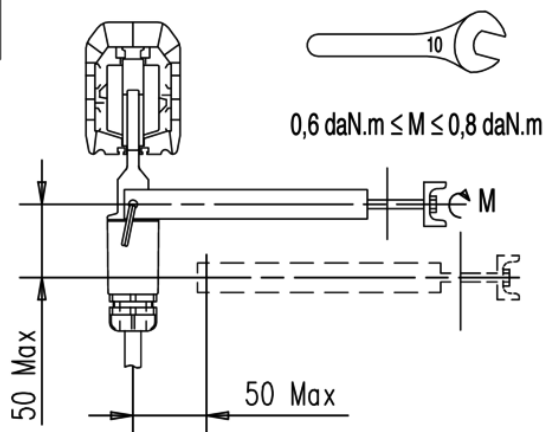

**La durée de vie des chariots diminue avec l'augmentation du décalage de l'entraînement**  
*More the driving in the axle is displaced, more the life time of the collector decreases*  
Je grösser die Mitnahme des Stromwagens von der Achse versetzt ist, desto vermindert sich die Stromwagenslebensdauer

**Maintenance**

This element does not require any special maintenance.

## Special carrier for long transfer element

Maintains the trolley in the air during the interval between long transfer elements.

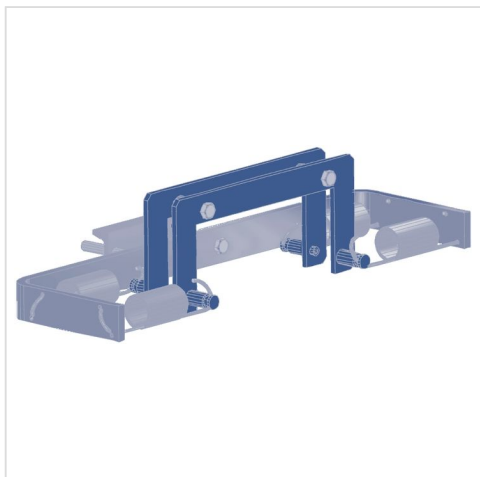

### Description

Whenever space between the transfer elements is greater than 30mm, the use of long transfer elements and this special carrier is required: it maintains the trolley in the air (simple, double or triple) in the clearance between the long transfer elements. It is useless when short transfer elements with a space less than 30mm are used.

### Categorie

Transfer

### Avantage n°1

Supports the trolley outside of the line

### Avantage n°2

Unique model for single, double or triple trolleys for special transfer elements

---

## Références et compatibilités

### Références et variantes

ME1680

### Disponible avec lèvres ?

compatible

### Disponible en version courbe ?

compatible

---

## Données techniques

### Données techniques

Assembling on square of 30 to 50mm, permitted horizontal clearance: +/-12mm, permitted vertical clearance: +/-15mm.

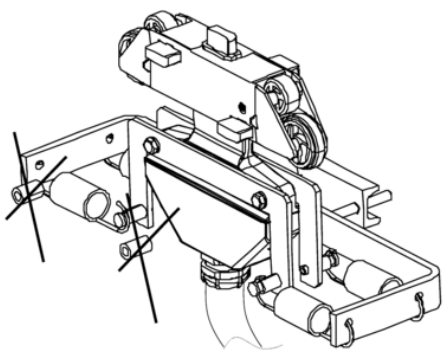
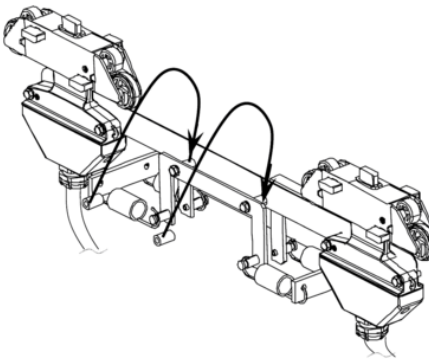
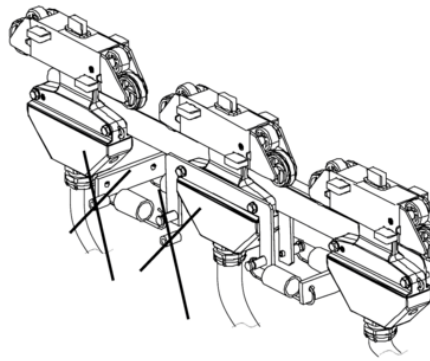

## Règle de montage 2

<p>Pour les chariots simples, supprimer les chaînettes et les entretoises :</p> <p><i>For the simple collectors, remove the chain line and the struts.</i></p> <p>Für die einfachen Stromabnehmerwagen, bitte Kettenlinie und Abstandshülse abnehmen</p>	<p>Pour les chariots doubles, installer les entretoises côté avant :</p> <p><i>For the double collectors, install the struts on the front side.</i></p> <p>Für die doppelten Stromabnehmerwagen, bitte Abstandshülse auf der Vorderseite einbauen.</p>	<p>Pour les chariots triples, supprimer les entretoises :</p> <p><i>For the triple collectors, remove the struts.</i></p> <p>Für die dreifachen Stromabnehmerwagen, bitte Abstandshülse abnehmen</p>
		

## Maintenance

This element does not require any special maintenance.

## Switching finger

End of travel electromechanical link stop.



### Description

Located on one element of the line, it allows the overhead travelling crane provided with a cross-type sensor limit switch to detect a position or the end of line with no other elements required to be fitted to the structure.

### Categorie

Standard

### Avantage n°1

Position can be changed easily

### Avantage n°2

Easy fit on the Mobilis line

## Références et compatibilités

### Références et variantes

ME1550

Disponible avec lèvres ?

compatible

### Disponible en version courbe ?

compatible

## Données techniques

### Encombrement

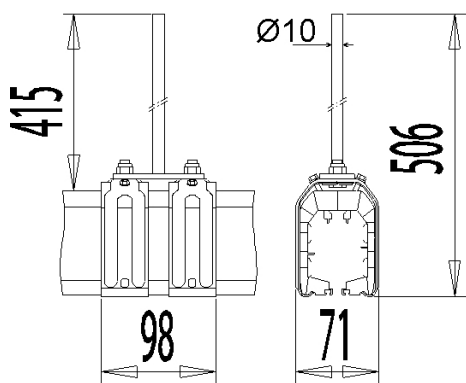

**Encombrement L x H x Z**  
**Température d'utilisation**

71 x 506 x 98  
-30°C to +75°C

**Poids**  
**Matière**

0,57 kg  
Zinc coated steel

---

## Montage

### Outils nécessaires au montage

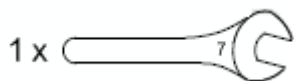

### Outils nécessaires au démontage

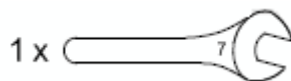

### Règle d'installation 1

To be positioned normally at each end of the line. Provide suitable space to allow the travelling crane to stop at full speed.

### Maintenance

This element does not require any special maintenance.

### Set of 5 screws + nuts 20A - 100A

Replacement connection screws and nuts for 1 element, intensity 20A to 100A.



**Categorie**

Accessories

---

## Références et compatibilités

**Références et variantes**

ME1345



## Set of feed connection for 5th pole

Screws and spacers for feeding connection 5th pole intensity 20 to 100A.



**Categorie**

Accessories

---

## Références et compatibilités

**Références et variantes**

ME1360

### Set of 10 screws + 5 nuts 130A

Replacement connection screws and nuts for 1 element 130A 5 poles.



**Categorie**

Accessories

---

## Références et compatibilités

**Références et variantes**

ME1357

## Set of connection screws 160A

Replacement connection part for 1 element 160A 5 poles.



**Categorie**

Accessories

---

## Références et compatibilités

**Références et variantes**

ME1353

## Set of connections for 200A 5 poles

Replacement connection part for 1 element 200A 5 poles.



**Categorie**

Accessories

---

## Références et compatibilités

**Références et variantes**

For elements 200A: ME1358, For 200A-TR elements: ME1358-TR

## Set of connection screws 200A

Replacement connection screws for phase and earth conductors on element 200A 5 poles.



**Categorie**

Accessories

---

## Références et compatibilités

**Références et variantes**

For elements 200A: ME1352, For 200A-TR elements: ME1352-TR

## Set of 4 collector brushes

Replacement brushes for single 4-pole trolley type ME3043 and derivatives.



**Categorie**

Accessories

---

## Références et compatibilités

**Références et variantes**

ME1354

## Set of 5 collector brushes

Replacement brushes for single 5-pole trolley type ME3051 and derivatives.



**Categorie**

Accessories

---

## Références et compatibilités

**Références et variantes**

ME1355

## Brush for simplified trolley

Replacement brush for simplified trolley type ME2034.



**Categorie**

Accessories

---

## Références et compatibilités

**Références et variantes**

ME0306



## Set of 5 cleaning brushes

Replacement brushes for single 5-pole cleaning trolley type ME4525 and derivative.



**Categorie**

Accessories

---

## Références et compatibilités

**Références et variantes**

ME1356

### Set of 2 special screws for fixed hangers

Converts a sliding hanger into a fixed hanger.



**Categorie**

Accessories

---

### Références et compatibilités

**Références et variantes**

ME1501

## Set of 2 carrier rings

Replacement rings linking the chains of the trolley to the carrier.



**Categorie**

Accessories

---

## Références et compatibilités

**Références et variantes**

ME1359

## Cone for short transfer element

Replacement cone for short transfer element.

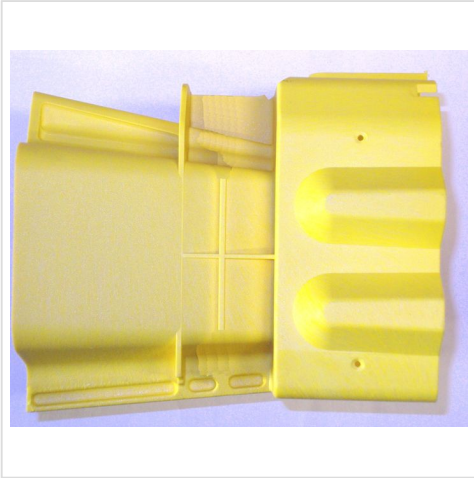

**Categorie**

Accessories

---

## Références et compatibilités

**Références et variantes**

ME0188

---

## Montage

### Règle de montage 1

Cut off mains voltage to the line. Remove the covering flange of transfer element using a flat screwdriver. Replace the cone making sure to insert all guiding studs of and the cone fully, remove the bridge maintaining the wings of the cone. Put back on the covering flange of transfer element.

## Cone for long transfer element

Replacement cone for long transfer element.



**Categorie**

Accessories

---

## Références et compatibilités

**Références et variantes**

ME0189

---

## Montage

### Règle de montage 1

Cut off mains voltage to the line. Remove the covering flange of transfer element using a flat screwdriver. Replace the cone making sure to insert all guiding studs of and the cone fully, remove the bridge maintaining the wings of the cone. Put back on the covering flange of transfer element.

# **MOBILIS**

**MOVIT**

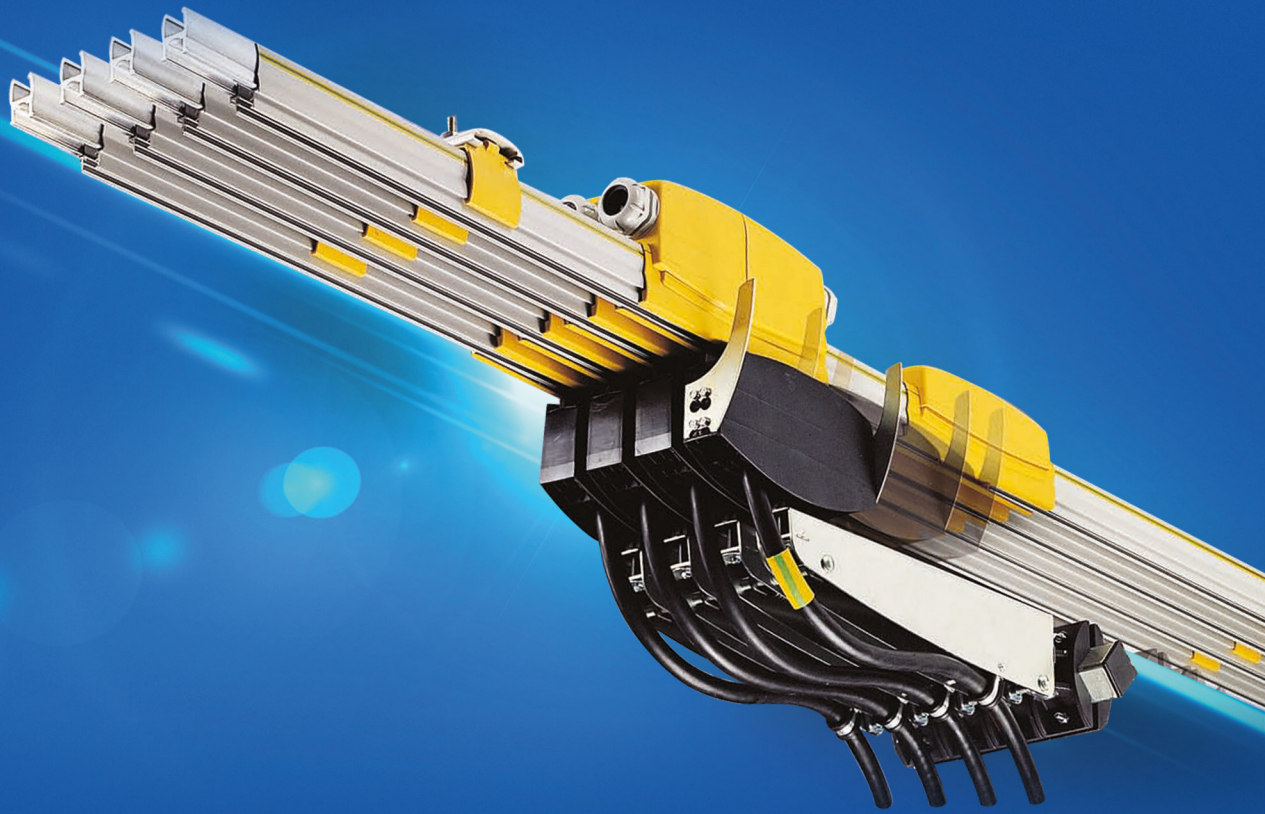

# MOBILIS MOVIT

The electrical supply rail Mobilis Movit meets the requirements of the most demanding manufacturers, installers, and end-users of mobile equipment of high power: **higher safety, easy installation, operation reliability, and easy maintenance** of this electrical supply rail for travelling cranes and other mobile equipment requiring mobile power socket.

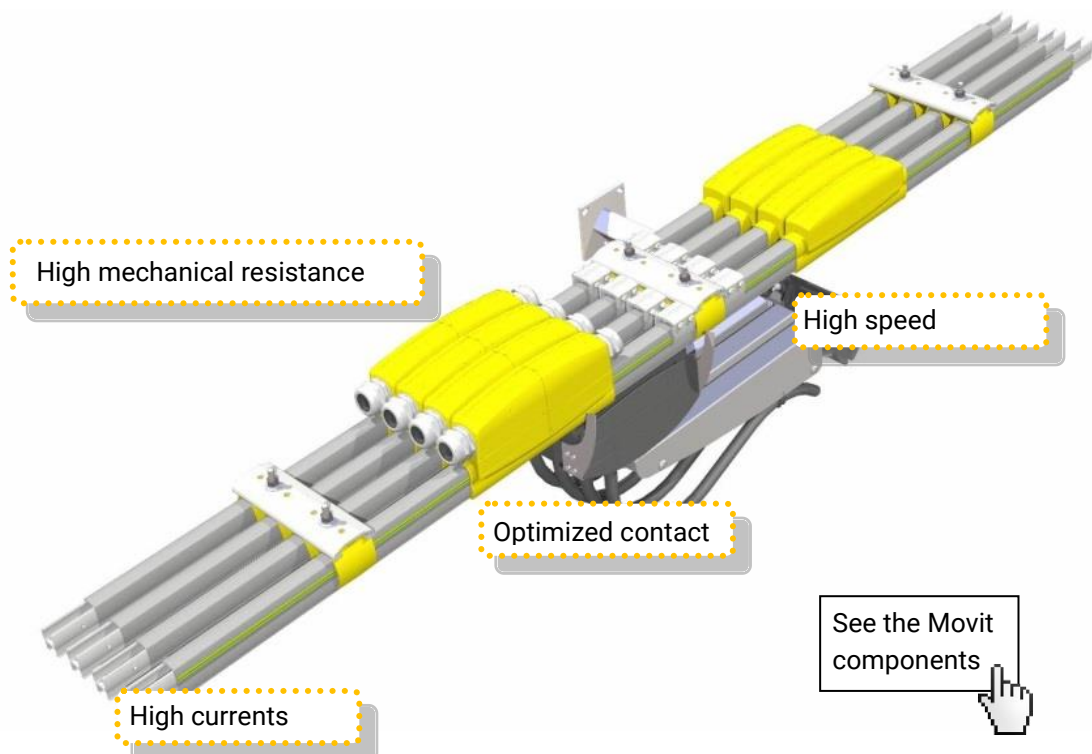

High speed: \_\_\_\_\_ up to 600m/min

High currents: \_\_\_\_\_ up to 630A

High mechanical resistance: Rigid H profile and sturdy accessories, ideal for applications where reliability, safety, and high performance are required

Optimized contact: \_\_\_\_\_ Angle offset is provided to control collector contact

## 1. DETAILS OF PROFILE

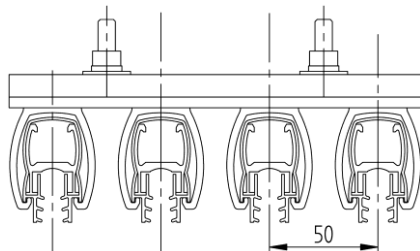

Number of poles: 1 to infinity  
Intensities: 315A, 450A, 630A  
Maximum voltage: 750V

### OUTSTANDING ADVANTAGES

- Flexible number of conductors
- Track of curved shape for optimized and controlled contact
- Reliable self-aligning connection with low voltage drop
- Easy and quick clipped-on mounting of line into its SUSPENSIONS
- Protection level IP23
- Modular and interchangeable

Mobilis Movit Presentation

## 2. STANDARDS

- Protection level IP23 according to EN60529
- Meets the requirements of Standards EN60439-2, CEI61439-6 and EN60204-32

## 3. SPECIAL ELEMENTS AVAILABLE

- Circuit interruption elements
- Compact expansion joints
- Curves
- Cleaning devices
- Heating cable

## 4. OUTSTANDING ADVANTAGES

- Innovative design
- Aluminum H profile of rail to provide maximum rigidity and compactness while making easier the fitting of an anti-icing device
- Curved shape of track for optimum contact, even when collector is disturbed or inclined
- Light weight and easy handling of aluminum rails of 4m length
- Simple, easy and quick clipped-on mounting of single conductors in the supplied pre-assembled multi-pole hangers, all accessories are pre-assembled in the factory (connections, hangers), and many accessories can be quickly mounted with no special tool : flanges, feed boxes, etc.
- Compactness with 50mm clearance between rails: takes up minimum space on side (unusual for this type of product)
- Compact patented self-aligning connection requiring only minimum preparation, of high current capacity thanks to optimized contact, and self-centered (supplied pre-assembled).
- Reduced voltage drop due to its low and optimized line impedance, and short connections
- Long line lengths without expansion joints (up to 350m)
- Compact expansion joints to take up overall minimum space for line
- Customizable number of conductors
- People safety guaranteed by the safety level IP 23 across the whole range and all accessories
- Running speed up to 600 m/min
- Reliability and mechanical resistance for exceptional service life while maintaining optimum characteristics
- Simple logistics, maintenance, and dismounting.



## 5. [GENERAL TECHNICAL DATA](#)

See related section  
(Uses, operating limits ...)

## 6. [COMPONENTS](#)

See related section  
(Straight elements, feed boxes, hangers, accessories ...)

## 7. [DOWNLOADS](#)

Visit the website: <http://catalogue.fels.fr/en/mobilis-movit/downloads>  
(Consultation Sheet, Assembly Instructions, CAD File Package)

## 8. GUARANTEE

Our equipment is guaranteed one year against any material or manufacturing defect recognized by ourselves. As we are not responsible for its installation and operation, our guarantee covers only replacement or repair (at our own choosing) of the part recognized to be defective.

We do not accept responsibility for any defects arising from faulty supervision or maintenance. We also disclaim liability for any production stoppages that may result. Any arbitration shall be held in Strasbourg, even when several defendants are involved.

# Mobilis MOVIT - Technical Data

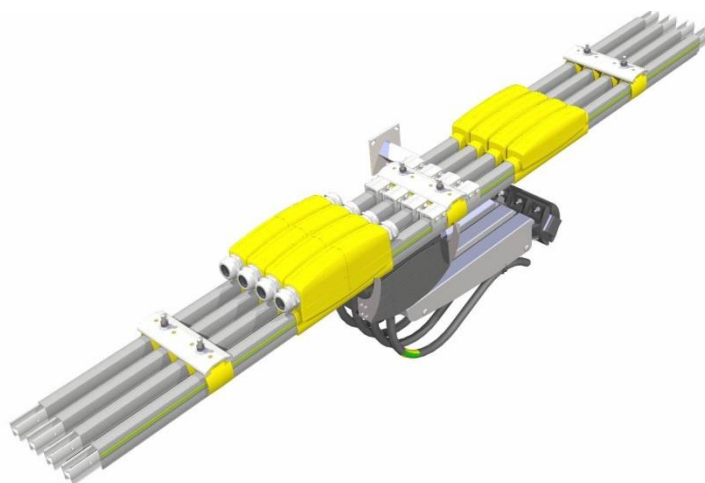

## 1. APPLICATIONS:

The single-conductor electrical supply rails with mobile socket are generally used for the electrification of travelling cranes, and heavy cranes and equipment, operating inside and outside.

## 2. GENERAL TECHNICAL DATA:

### Rated intensity:

The MOVIT ELITE lines are available in several intensities 315A, 450A, and 630A

### Number of poles :

Modular from 1 pole, the protection conductor (PE) is marked with a green-yellow stripe

### Rated voltage:

750VAC at 50Hz or 60Hz

### Temperature of use:

-30°C to +55°C

### Protection against short-circuits:

Please inquire for intensities above  $I_{cw}$  8.5 kA 0.2s and  $I_{pk}$  17kA

### Protection against fire:

All plastic accessories used with the Mobilis Movit lines are self-extinguishing

### Weight :

0,81kg/m for 315A ; 1,03kg/m for 450A ; 1,26kg/m for 630A

## 3. ENVIRONMENT :



Validate suitability of the product to run in unfavorable environmental conditions (e.g. humid air flow, steam, frost...).

A version with 600h resistance under saline mist is available. Please inquire.

An unfavorable environment brings the following risks

Legend :   +++ High risks  
               ++ Moderate risks  
               + Low risks

Risk \ Environment	Reduction of insulation distances	Corrosion of metal parts (incl. conductors)	Losses of contact	Damage to thermoplastics	Disruption of movements of mobile elements (collectors, expansion joints)	Recommendations
Humidity	+	+	+	/	/	Periodical cleaning trolley Double trolley
Outside use	/	+	+	+	/	Under high UV environment, install a shelter (protective roof)
Dust	/	/	+++	/	/	Periodically cleaning trolley Double trolley
Frost, snow, ice	/	/	+++	/	+++	Anti-frost heating cable Shelter (protective roof) Double collector
Inland port	+	+	+	/	/	Double collector
Marine environment	++	+++	+++	/	/	Double collector Strengthened surface treatment (please inquire)
Chemical environment	++	+++	+++	+ / +++	/	Check appropriate use of materials in conjunction with products (please inquire) Periodical cleaning trolley Double collector Strengthened surface treatment (please inquire)

#### 4. APPLICABLE STANDARDS:

The Mobilis Movit range has been designed to meet Standards EN60439-2 and EN60204-32. It bears the  marking.

#### 5. PROTECTION INDEX:

A mounted line with the full set of accessories has a protection level of IP23 according to EN60529, with no lips and with dust protection lips.

Caution: If one accessory is removed, the level of protection is eliminated.

IP2X means that the equipment is protected so that people cannot access the dangerous sections, i.e. it is impossible to introduce a standard test finger of Ø12 mm with an effort of 10 N. The equipment is also protected against solid foreign bodies, i.e. it is not possible to introduce a metal sphere of Ø12.5 mm with an effort of 30 N.

IPX3 means that the equipment is protected against rainwater falling at a maximum angle of 60° in relation to the vertical plane.

The Mobilis Movit range is designed for both inside and external use.

If a Mobilis Movit line is used in an area open to the public, additional safety measures should be installed (protection level IP4X required according to EN60204-32).

## 6. INSULATION DISTANCES:

The insulation distance between conductors or between conductors and accessible parts:

- Distance in the air: 10 mm min.
- Creepage distance: 30 mm min. (according to Standard EN60204-32).

## 7. FLAME RESISTANCE:

All materials used to build Mobilis Movit lines are self-extinguishing; they pass successfully glowing/hot line tests under 960°C for elements in contact with live parts and V-0 according to UL-94.

## 8. SAFETY PINS

Rail: The ground rail is marked on the line with a green-yellow band. The ground conductor should be installed on the outer side.

Collector: with the safety pin system, it is not possible to insert a ground collector trolley incorrectly (on phase), leading to a phase-earth connection.

## 9. SPACE REQUIREMENTS :

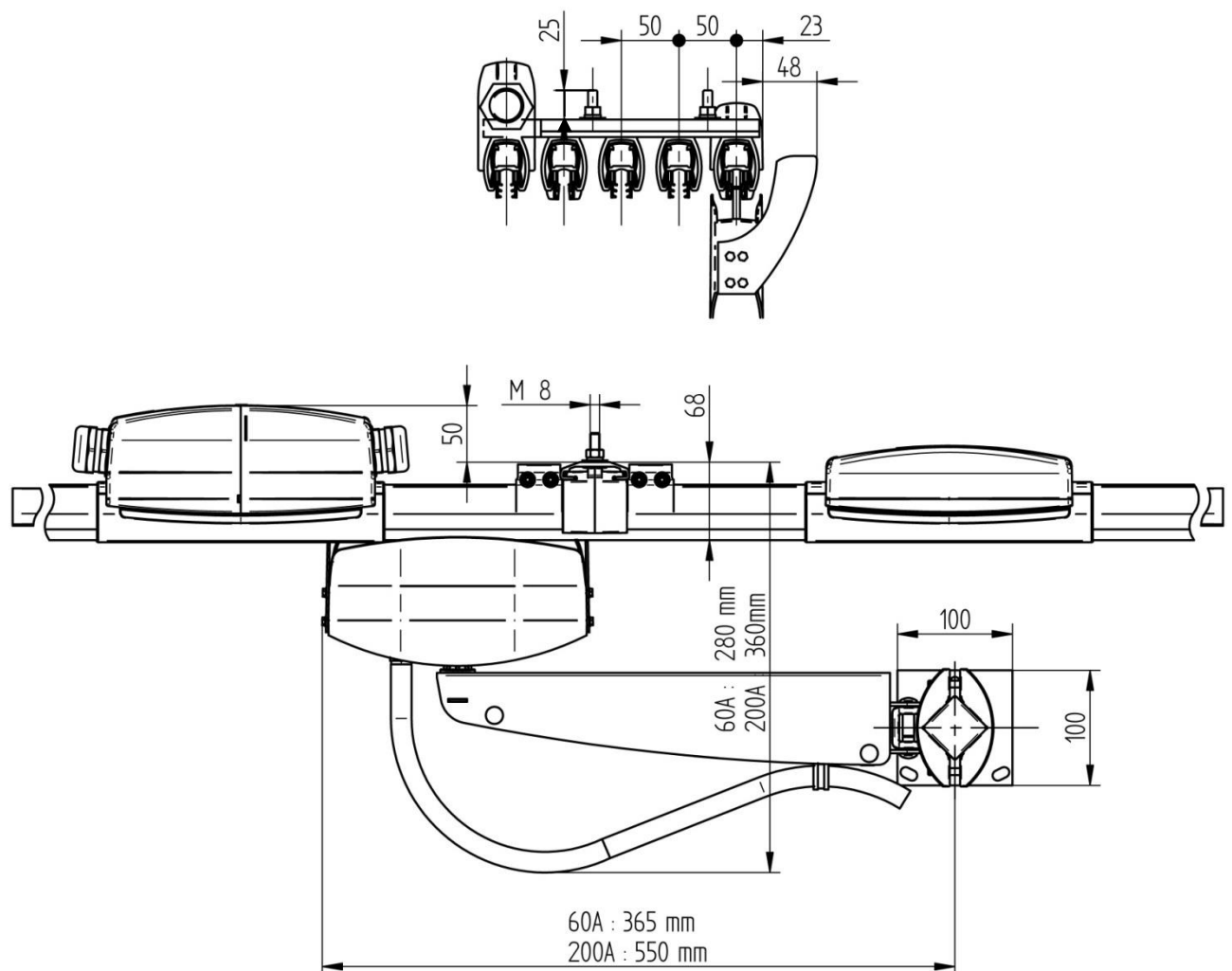

## 10. LIFETIME – ENDURANCE :

The lines and accessories are built to withstand several years of use in a normal industrial environment. The current collectors are designed to run for several thousand kilometers. See the Maintenance section to know the maintenance visit frequency.

## 11. CALCULATION DATA:

IMPULSE RUNNING:

For determining the intensity, please refer to the data below and to the section [Line calculation](#)

Correction factor f:

When the ambient temperature is different from 35°C, it is necessary to correct the value of the maximum permissible intensity for a 100% duty cycle :

$\theta$ (°C)	315A	450A	630A
30	1,36	1,2	0,98
35	1,23	1,11	0,90
40	1,14	1	0,84
45	1	0,91	0,75
50	0,90	0,80	0,68
55	0,8	0,71	0,61

Impedance on line :

Intensity	315A	450A	630A
R <sub>20</sub> or R at 20°C (Ω/m)	0,000188	0,000124	0,0000954
R at 35°C (Ω/m)	0,000199	0,000132	0,000101
R at 40°C (Ω/m)	0,000203	0,000135	0,000103
X (Ω/m at 50Hz)	0,00011	0,00011	0,00011
Z <sub>20</sub> or Z at 20°C (Ω/m at 50Hz)	0,000218	0,000166	0,000146
Z at 35°C (Ω/m at 50Hz)	0,000227	0,000172	0,000149
Z at 40°C (Ω/m at 50Hz)	0,000231	0,000173	0,000151

Under Fault condition:

I<sub>cw</sub> 8,5kA/0,2s

I<sub>pk</sub> 17kA

Permissible Current according to Duty Cycle :

Intensity	315A	450A	630A
<b>Rated Intensity</b>	<b>315A</b>	<b>450A</b>	<b>630A</b>
Duty Cycle Factor for rated intensity at 35°C	100%	100%	75%
Maximum permissible current at 35°C for 100% Duty Cycle	395A	500A	570A
Maximum permissible current at 35°C for 80% Duty Cycle	420A	540A	638A
Maximum permissible current at 40°C for 100% Duty Cycle	360A	460A	530A
Maximum permissible current at 40°C for 80% Duty Cycle	384A	495A	580A

Permissible Duty Cycle Factor according to the maximum operating temperature

$\theta$ (°C)	315A	450A	630A
30	100%	100%	95%
35	100%	100%	75%
40	100%	100%	58%
45	100%	89%	44%
50	100%	67%	32%
55	76%	39%	22%

## 12. [LINE CALCULATION](#)

See related section

(Data required for calculation, calculation method, charts...)

## 13. [ONLINE CALCULATION TOOL](#)

See <http://www.fels.fr/extranet/>

(Online calculation with intensity suggested based on data submitted)

## 14. [COMPONENTS](#)

See related section

(Straight elements, trolleys, feeding boxes...)

Horizontal curves: Curvature radius < 15m, please inquire

## 15. [ASSEMBLY INSTRUCTIONS](#)

See related section

## 16. GENERAL MAINTENANCE

Any intervention must be carried out **with the line switched off at the mains**.

Maintenance primarily concerns the brushes of the collectors and the conductive tracks of the rails.

### CHECKING THE BRUSHES

The average service life of the brushes is 2,000 km.

With the line switched off, take the collector casing out of the rail.

200A Collector:

Brush replacement: the wear limit is the base of the chamfer.

Limite d'usure : début du chanfrein  
Wearing limit : beginning of the chamfer  
Verschleissgrenze : Anfang der Abschrägung

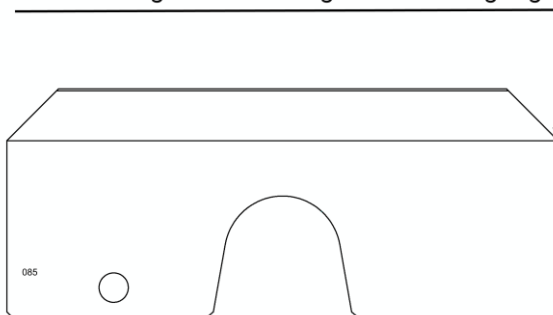

Pull up the brush to take it out of the pantograph casing, and unfasten the bolted link with the cable. Make sure the cable lug and the screw are placed correctly upon re-assembling!

60A Collector:

Brush replacement: the wear limit is the base of the chamfer.

Limite d'usure : début du chanfrein  
Wearing limit : beginning of the chamfer  
Verschleissgrenze: Anfang der Abschrägung

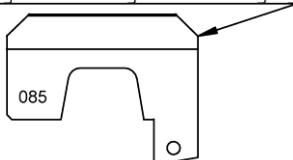

Unfasten and take out the brush fastening screw. Remove the brush and replace. Re-assemble in the reverse order.

After the brushes are fitted, make sure that the head of the collector rests smoothly in a neutral position (horizontally and in the axis).

### MONITORING AND RENOVATION OF TRACKS

Track surface quality can deteriorate in different ways: under the action of dust, or with the presence of pitting (due to arcing...).

Schedule periodic maintenance (according to environment, rate of use ...) to run the cleaning trolley.

Perform several passages back and forth with the cleaning brushes (abrasive foam) to remove all dust and all solid deposits, then repeat the operation with edging brushes (sanding belt, grit 120) to improve brushes quality surface.

Single collectors: facing the cleaning collector, clean the rails one by one.

Double collectors: replace a collector brush by a maintenance brush; fasten the cable to one of the maintenance collector.

Once the lines have been cleaned up, remove the cleaning collector (or put back on the collector brush in the case of double collectors), since this system is not designed to run over long distances (see section on Cleaning collector).

#### MONITORING OF GROUND CONTINUITY

When one (or several) expansion joints are fitted, the ground continuity on each expansion joint should be checked: once every two years

#### MAINTENANCE OF CIRCUIT INTERRUPTIONS

When one (or several) circuit interruptions are present, the insulation of the circuit interruption elements should be checked by means of an insulation controller, at a voltage higher than the rated voltage.

The insulation sectors should be cleaned, as necessary.

#### SPARE PARTS

- ⇒ Replacement Brush: 60A = MC0114 ; 200A = MC8041
- ⇒ Simple cleaning Brush: MC4190

### 17.GUARANTEE :

Our equipment is guaranteed one year against any material or manufacturing defect recognized by ourselves. As we are not responsible for its installation and operation, our guarantee covers only replacement or repair (at our own choosing) of the part recognized to be defective. We do not accept responsibility for any defects arising from faulty supervision or maintenance. We also disclaim liability for any production stoppages that may result. Any arbitration shall be held in Strasbourg, even when several defendants are involved.



## Rail

Straight single-pole element with its insulation envelope.



### Description

The rails are straight elements used to conduct the electrical current all along the line and allow current shunting by means of friction collectors. One rail is required per pole. They are available in 3 intensities: 315A, 450A and 630A. Conductor made of aluminum alloy, a material offering the best compromise between conductivity, weight and price. The stainless steel track crimped onto aluminum provides the face of friction for current shunting. Phase versions and earth versions are available, gray envelope for phases, gray envelope with standard green-yellow earthing on both faces of the element. The envelope ensures the electrical insulation and protection against direct contact. Available in standard lengths of 4m, 3m, 2m, and 1m, and in special lengths. Acceptable intensities are valid in 50Hz, 60Hz and DC. Horizontal curves are possible, please enquire indicating radius and angle: minimum curve radius of 15m.

<b>Categorie</b>	Standard	<b>Avantage n°1</b>	Aluminum structure
<b>Avantage n°2</b>	Stainless steel friction track		

---

## Références et compatibilités

### Références et variantes

References of the rails:

## Références et variantes

Intensity	315A		450A		630A	
Maximum Duty Cycle for the rated current at 35°C/at 40°C	100% / 100%		100% / 100%		75% / 58%	
Maximum Current for 80% duty cycle at 35°C / at 40°C	420A / 384A		540A / 496A		638A / 580A	
Section L1, L2, L3, N, PE	Alu 160mm <sup>2</sup>		Alu 245mm <sup>2</sup>		Alu 330mm <sup>2</sup>	
Weight (kg/m)	0,81		1,03		1,26	
Type	Phase	Earth	Phase	Earth	Phase	Earth
Length 4m	MC1314	MC1324	MC1414	MC1424	MC1614	MC1624
Length 3m	MC1313	MC1323	MC1413	MC1423	MC1613	MC1623
Length 2m	MC1312	MC1322	MC1412	MC1422	MC1612	MC1622
Length 1m	MC1311	MC1321	MC1411	MC1421	MC1611	MC1621
Special length	MC1310	MC1320	MC1410	MC1420	MC1610	MC1620
Rail color	Grey	Grey + green-yellow stripe	Grey	Grey + green-yellow stripe	Grey	Grey + green-yellow stripe

## Données techniques

### Encombrement

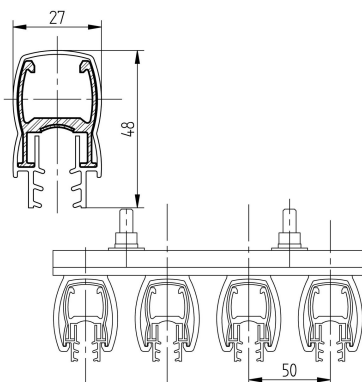

### Encombrement L x H x Z

27 x 48 x 4000

### Poids

see table des références

### Tension d'emploi

750V

### Température d'utilisation

-30°C to +55°C

### Calibre

315A, 450A, 630A

### Matière

Aluminium, Stainless steel track, self-extinguishing PVC Envelope light grey

# Montage

## Outils nécessaires au montage

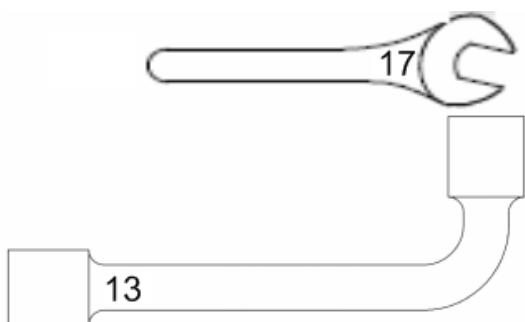

## Outils nécessaires au démontage

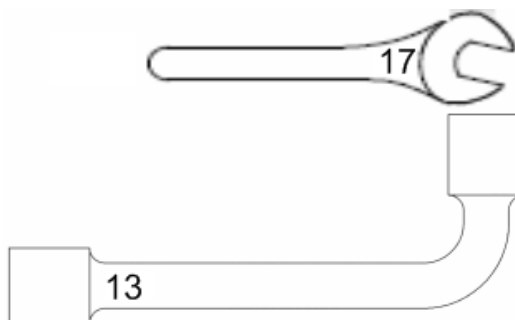

( + MC8025 )

## Règle d'installation 1

One line of rail is required per phase and earth pole. The poles are grouped according to the groups of sliding hangers. For lengths above 250m, check if an expansion joint is needed according to the rules suggested. The end of the rails must be within 0.5m of sliding hangers. The earth rail must be in the location the furthest away from the running beam, to make the foolproofing system of the current collectors effective.

## Règle de montage 1

Position always the earth rail in the location the furthest away from the running beam. Always prepare the ends of the rails according to our instructions before making the connections.

## Règle de montage 2

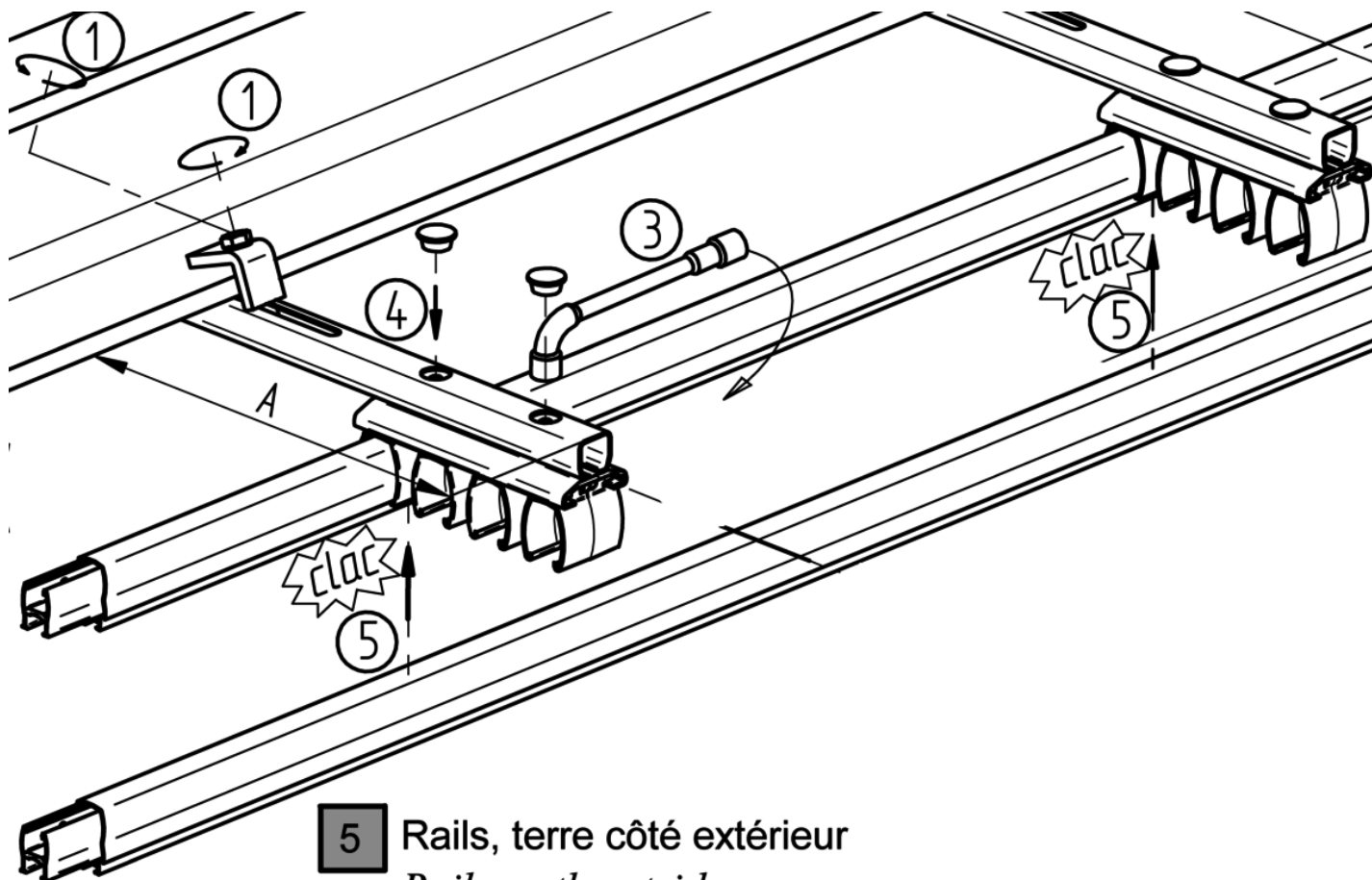

**5** Rails, terre côté extérieur  
*Rail, earth outside*  
Schienen, Erde aussen

## Maintenance

Check the friction tracks periodically, use a cleaning collector when clogging or damage of the tracks is detected. This damage to the surface of the track may take various forms: abrasive dust, damage due to electrical arcs, etc. Regular inspection is required to check the wear of the brushes and the quality of the conductive tracks according to the rate of use, the distance covered and the chemical environment, and run the cleaning collector.

## Connection

Provides the electrical and mechanical link connection between the single conductors.



### Description

The purpose of the connection is to provide a rigid electrical and mechanical connection between the single conductors. For the feed box and each junction between the rails, standard for all intensities, pre-mounted in factory. Optimized contact with the rail and positioning guided by pin, to be installed after preparation of aluminum rail ends. The connection itself requires no preparation before assembling. After assembling, the connection provides an available space in rail core where a heating cable can be installed later on.

<b>Categorie</b>	Standard
<b>Avantage n°1</b>	Ensures self-alignment of rails
<b>Avantage n°2</b>	Fast assembling by only 3 screws with easily access from the top

## Références et compatibilités

<b>Références et variantes</b>	MC1000
--------------------------------	--------

## Données techniques

<b>Données techniques</b>	Length 80mm	<b>Poids</b>	0,3 kg
<b>Calibre</b>	315A, 450A, 630A		
<b>Matière</b>	Aluminium and zinc coated steel		

# Montage

## Outils nécessaires au montage



## Outils nécessaires au démontage



### Règle d'installation 1

Provide 1 connection per junction the between rails. No connections end of line.

### Règle de montage 1

A connection requires preparation of the rail ends before it can be installed, to eliminate oxides present on the aluminium surface and to preserve the quality of the contact over time.

**7** Connexions  
*Connexions*

Verbindungselementen



1) Brosser  
*Brush*  
 Bürsten

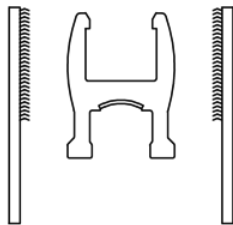

2) Essuyer  
*Wipe*  
 Abwischen

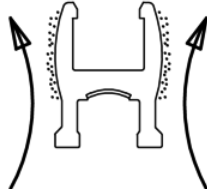

3) Graisser avec MC1010  
*Grease with MC1010*  
 Schmieren mit MC1010

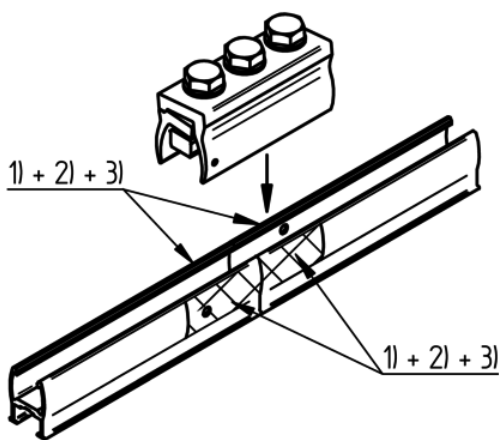

4) Raccorder  
*Connect*  
 Verbinden

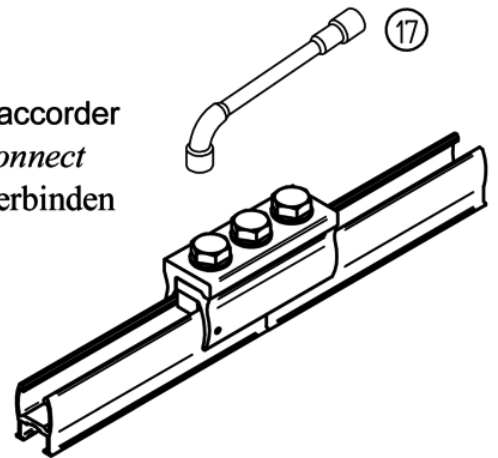

Avant serrage  
*Before tightening*  
 Vor anziehen

Venir en appui  
*in abutment*  
 in Anschlag



Après serrage  
*After tightening*  
 Nach anziehen

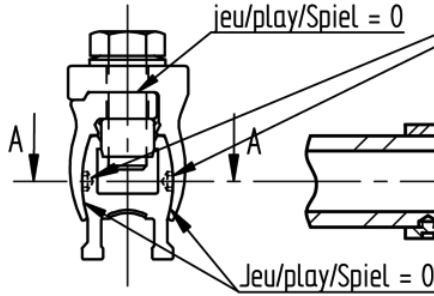

Tétons dans les trous  
*Pins in the holes*  
 Vorsprungen in Löcher

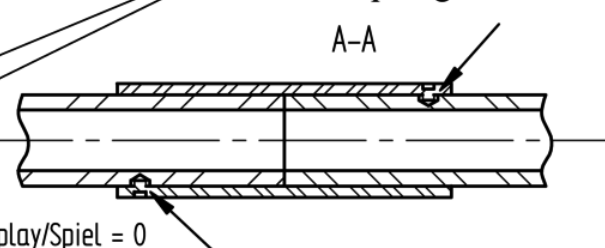

**Maintenance**

This element does not require any particular maintenance.

## Covering flange

Accessory for electrical insulation of the junctions.

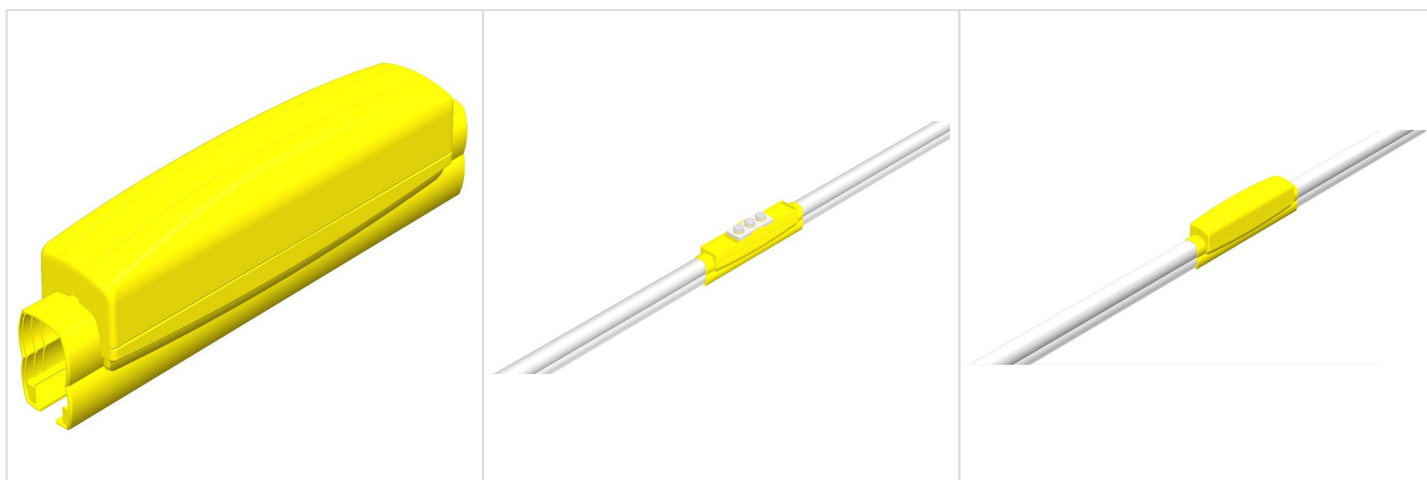

### Description

The purpose of the covering flanges is to ensure the protection of operators against direct contact with the junctions. Each connection has its own covering flange. Assembling only possible when connections have been made. It is suitable for passing a de-icing cable. Each covering flange has 2 components: - a common base with 2 articulated wings. - a lid made of the same material. The 2 components are delivered pre-assembled.

### Categorie

Standard

### Avantage n°1

Clip-on assembling, no tools needed

### Avantage n°2

IP23 Protection of the connections

## Références et compatibilités

### Références et variantes

MC2200

## Données techniques

### Données techniques

Index of protection once assembled on the rail: IP23

### Encombrement L x H x Z

42 x 90 x 250

### Poids

0,17 kg

### Tension d'emploi

750V

### Température d'utilisation

-30°C to +55°C

### Calibre

315A, 450A, 630A

### Matière

Self-extinguishing thermoplastic



# Montage

## Outils nécessaires au montage



## Outils nécessaires au démontage



## Règle d'installation 1

Provide a covering flange on each connection at the junctions of the rails (except at the feeding points).

## Règle de montage 1

To be installed/dismounted on the line with mains voltage cut off. 1. Hang the base by its clips 2. Clip on the lid to lock.

**8** Couvre-joint  
Covering flange  
Verbindungsabdeckung

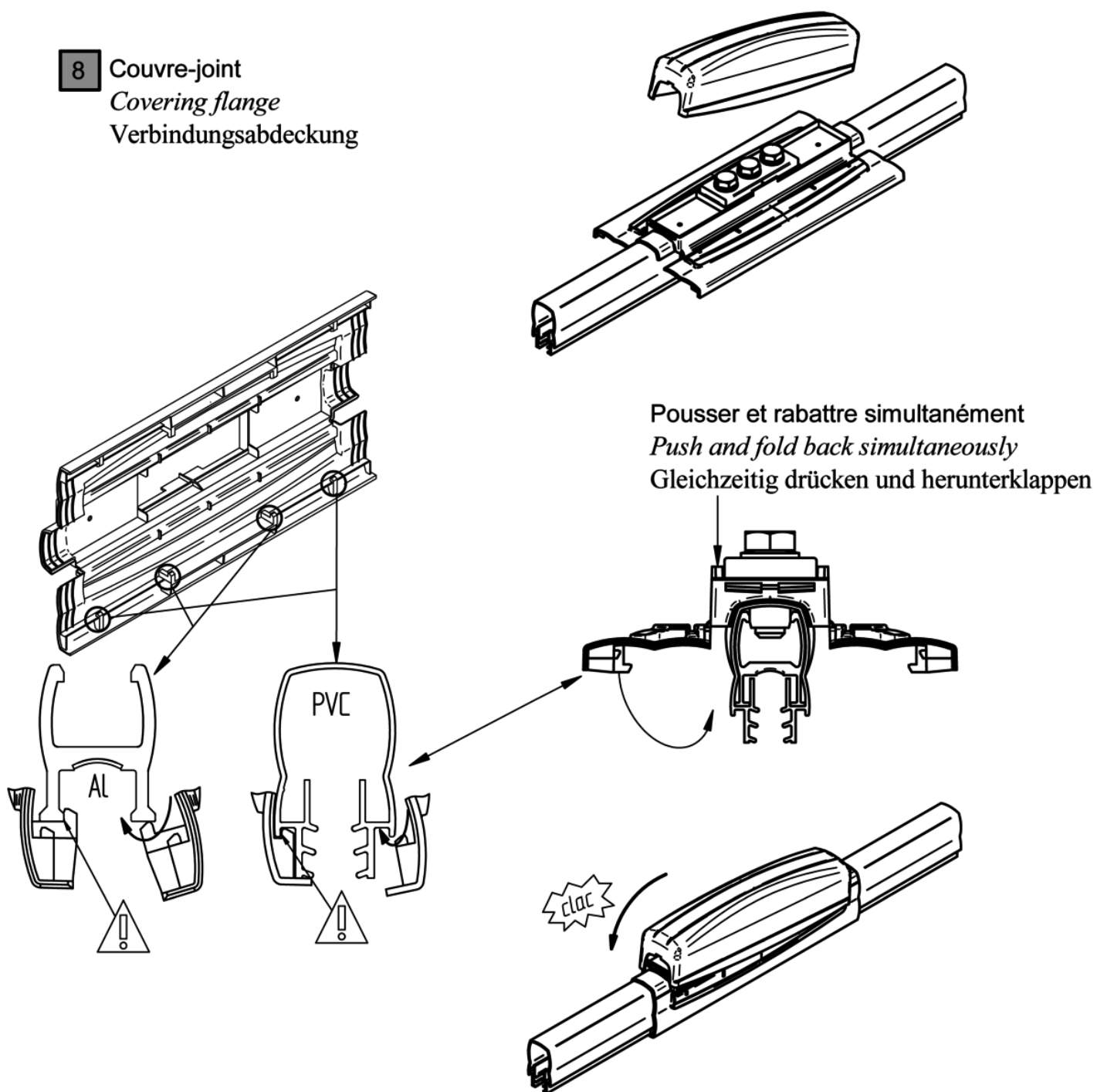

**Maintenance**

This element does not require any particular maintenance.

## Feeding box

Interface accessory for the electrical connection of one pole of the line at a junction in-line.

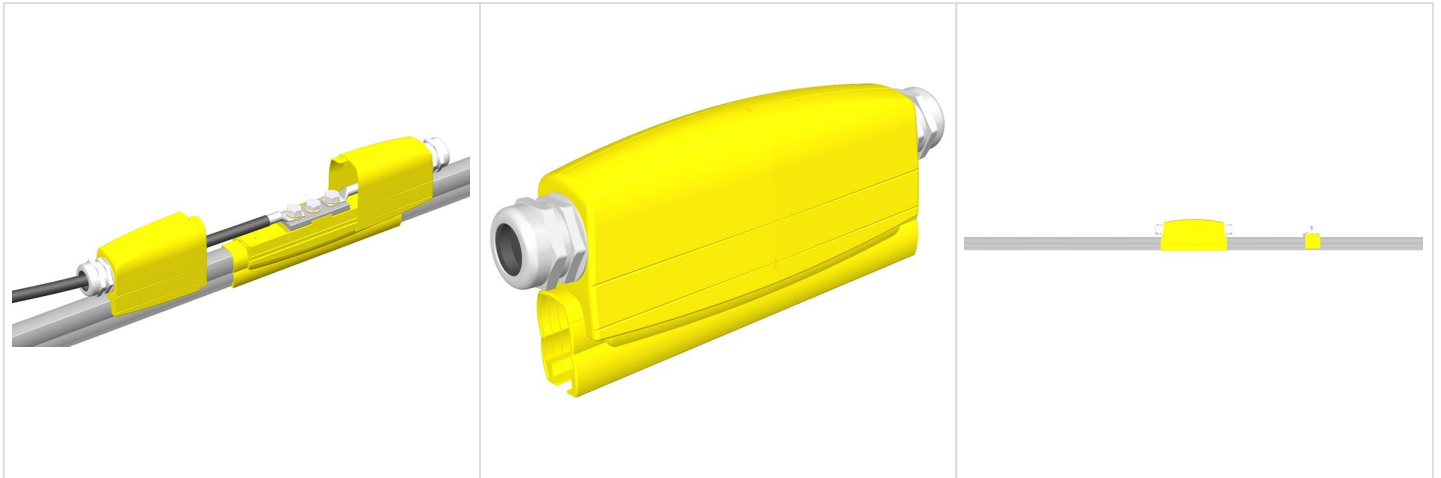

### Description

The purpose of the feed boxes is to carry out the electrical connection of the rails with the electrical installation. They are linked up to a connection in place of a covering flange, and ensure the protection of the operators against direct contact with live parts, as do covering flanges. Their position in the line is determined by the calculation of voltage drops. Each pole shall have its own feed box. A single model of feed box is used for all intensities. A feed box includes: - a common base. - 2 half-lids support each a M32 cable gland. - a self-stick label of identification of the poles. Connection shall be made by 1 or 2 flexible cables, type HO7 RNF, equipped with cable eye stiffeners to be crimped with connection Ø10 suitable to the connection screws. We can provide the cable eye stiffeners for cables 50, 70 and 95 mm<sup>2</sup>. The cable glands are suitable for cables of diameter 15 to 25 mm (type HO7RNF 35 mm<sup>2</sup> up to HO7RNF 120 mm<sup>2</sup>). The feed boxes are delivered fully pre-mounted.

### Categorie

Standard

### Avantage n°1

Introduction by 2 M32 cable glands closed by caps

### Avantage n°2

Closing of box without tool

## Références et compatibilités

### Références et variantes

MC2300

## Données techniques

### Données techniques

M32 cable glands for cables Ø 15 to 25. Connection by 1 or 2 cable eye stiffeners with hole Ø10, each one on a separate screw. Maximum intensity by cable eye stiffener: 315A.

### Encombrement L x H x Z

50 x 120 x 290

### Poids

0,36 kg

### Tension d'emploi

750V

### Température d'utilisation

-30°C to +55°C

### Calibre

315A, 450A, 630A

### Matière

Self-extinguishing thermoplastic

# Montage

## Outils nécessaires au montage

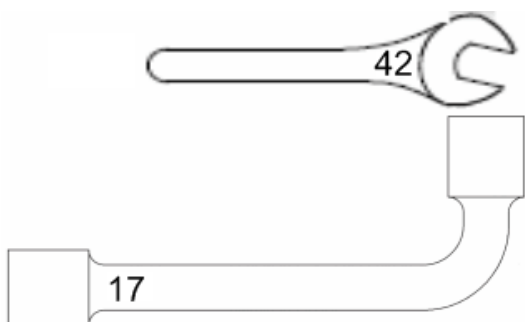

## Outils nécessaires au démontage

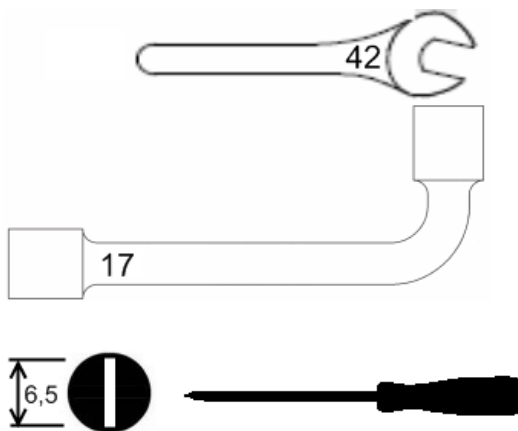

## Règle d'installation 1

Use a flexible cable for connection or provide a free-standing loop large enough to allow for line expansion. Providing one or more feeding point in line rather than end-of-line reduces the voltage drop ( $\Delta U = L \cdot I \cdot Z$ ) and allows to choose a lower intensity because the length 'L' taken into account in the calculation varies according to the number of feed boxes. Providing a feeding point midway in the line reduces by half the voltage drop, as the 'L' section taken into account equals half the length of the line. For more than one feeding point in line, please review the following graph for the required position of the points and related voltage drops.

## Image d'installation

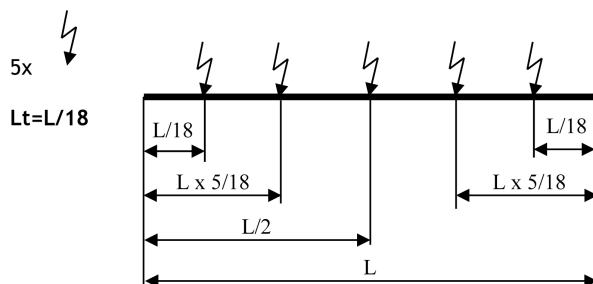
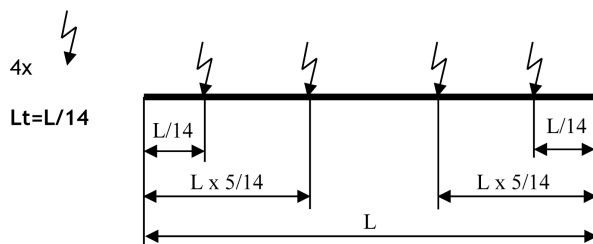
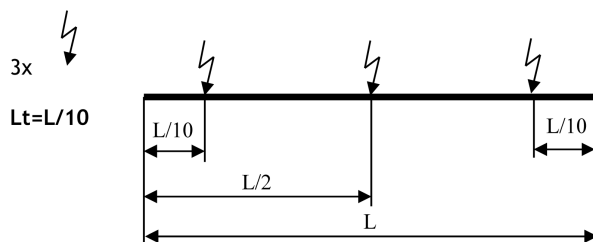
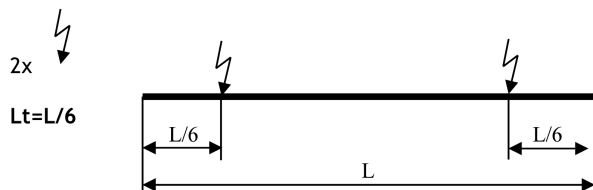
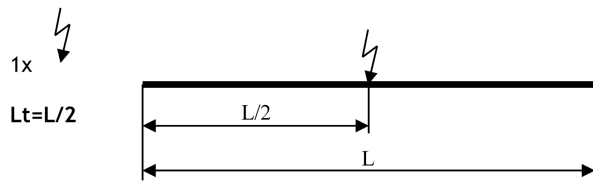
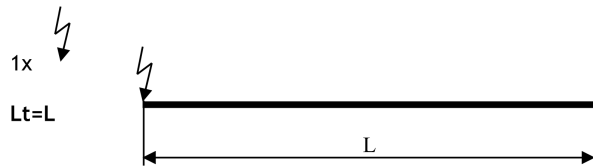

## Règle de montage 1

1. Fit on the connection 2. Open the feeding and position it on the connection 3. Pass the cables through the cable glands 3. Crimp the cable eye stiffeners and connect them to connection 4. Close the feeding and tighten the cable glands.

## Règle de montage 2

- 9** Alimentation  
Feed Box  
Einspeisung

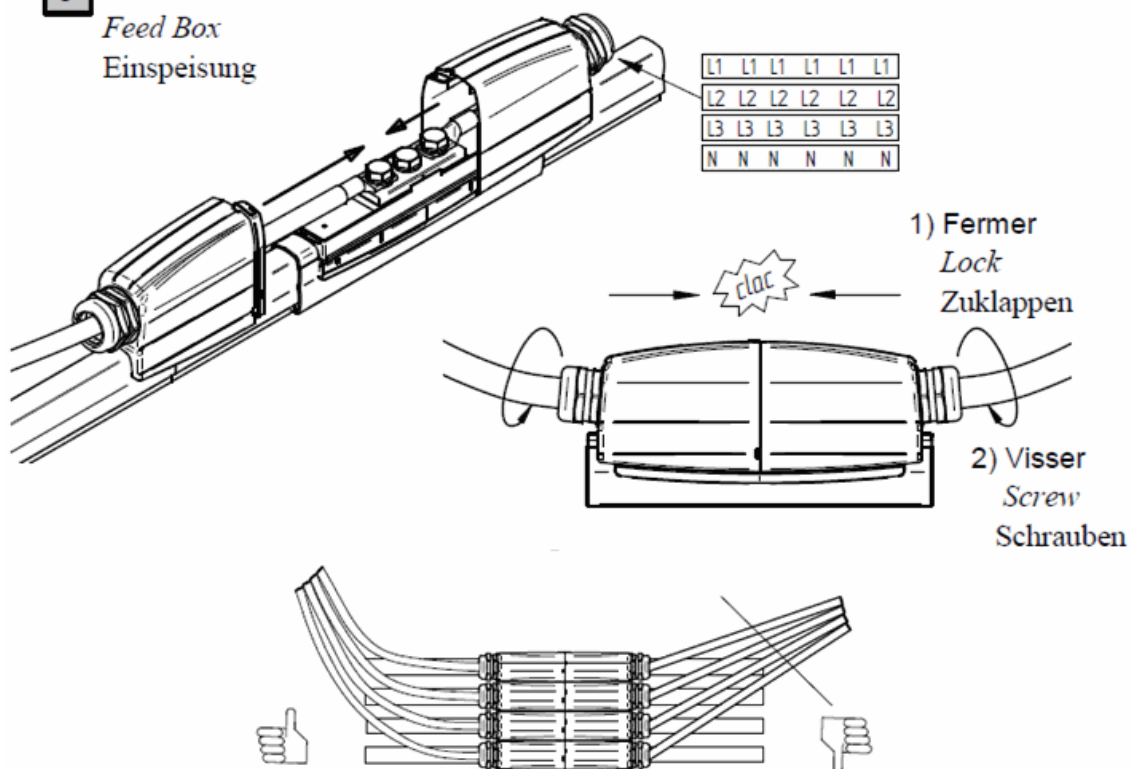

Les câbles ne doivent pas gêner la dilatation des rails.  
Cables must not impede expansion of the rails.  
Kabeln dürfen die Ausdehnung der Schienen nicht behindern.

## Démontage (si nécessaire) / Disassembling (if it is needed) / Demontage (wenn notwendig)

- 1) Frapper  
Hit  
Schlagen

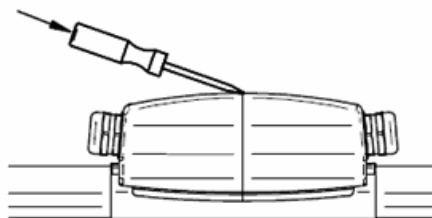

- 2) Séparer  
Separate  
Trennen

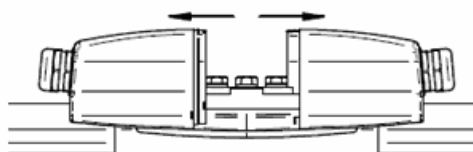

## Maintenance

This element does not require any particular maintenance.

## End-cap

Provides the insulation of live elements at the ends of the line.

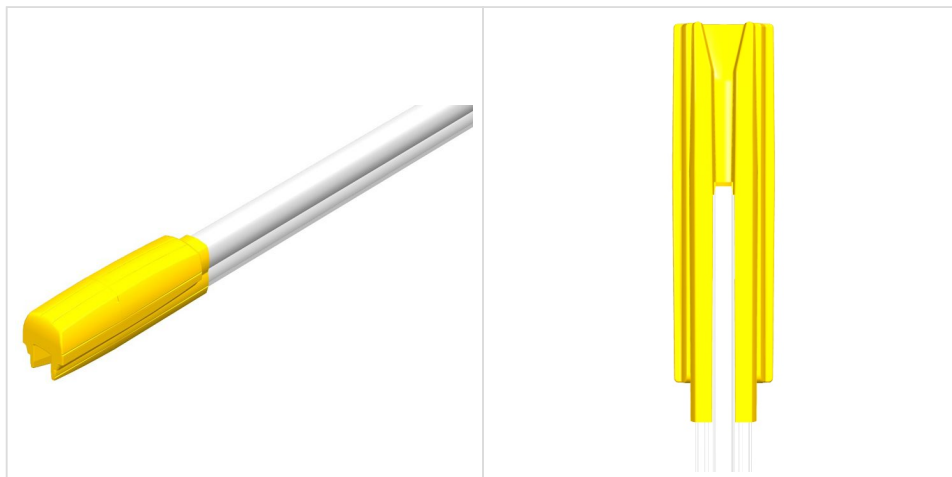

### Description

The end-caps must be placed at each end of the line to ensure the protection of the operators.

### Categorie

Standard

### Avantage n°1

Clip-on assembling, no tools needed

### Avantage n°2

Protection IP23 for the ends of the line

## Références et compatibilités

### Références et variantes

MC2400

## Données techniques

### Données techniques

Dépassement par rapport à l'extrémité du rail : 79mm

### Encombrement L x H x Z

50 x 70 x 190

### Poids

0,14 kg

### Tension d'emploi

750V

### Température d'utilisation

-30°C to +55°C

### Calibre

315A, 450A, 630A

### Matière

Self-extinguishing thermoplastic, stainless steel

## Montage

### Outils nécessaires au montage

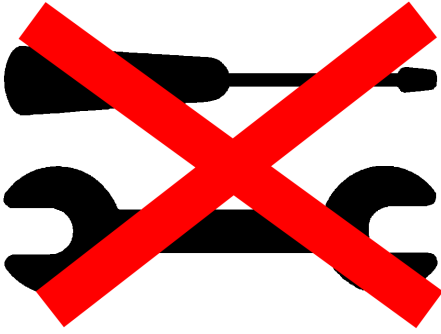

### Outils nécessaires au démontage



### Règle d'installation 1

To be positioned end of line. Provide enough space so as not to impede line expansion (minimum of 6cm for 50metres, minimum of 2.5cm for 100metres).

### Règle de montage 1

To be installed/dismounted on the line with mains voltage cut off.



## Règle de montage 2

**10** Capot de fermeture  
End-cap  
Endkappe

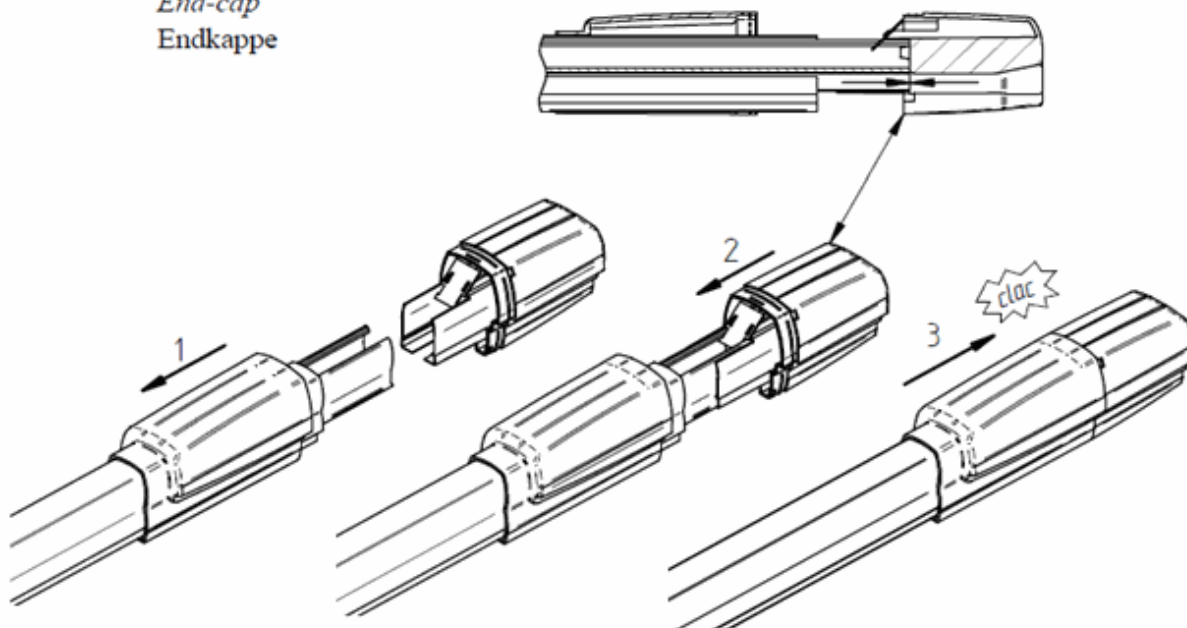

Démontage (si nécessaire) / Disassembling (if it is needed) / Demontage (wenn notwendig)

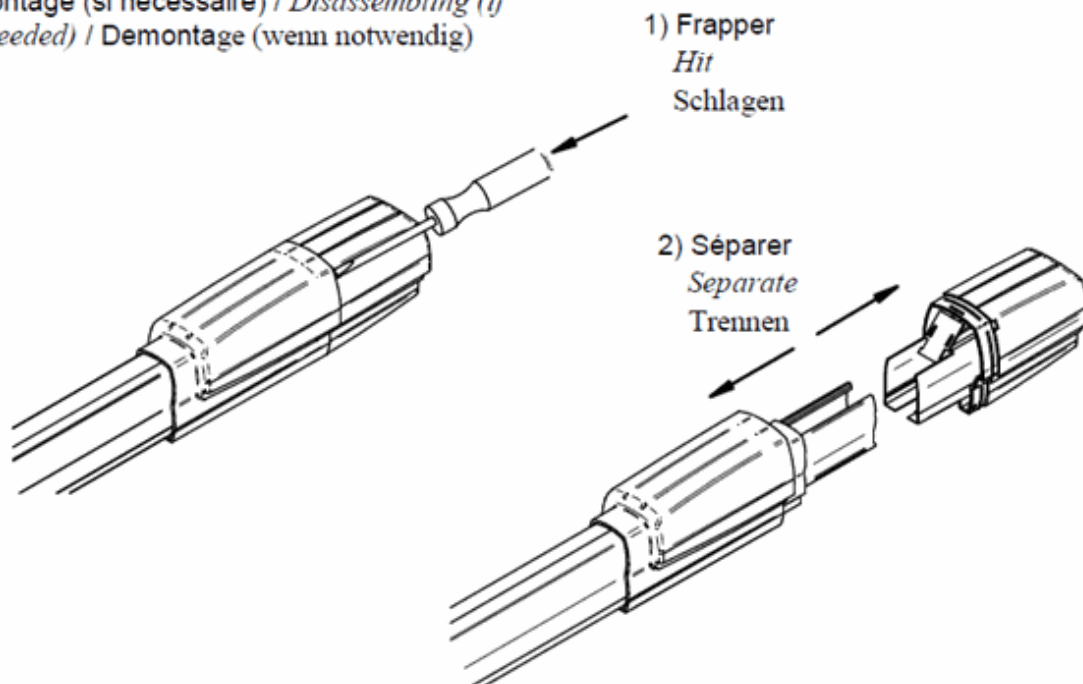

1) Frapper  
Hit  
Schlagen

2) Séparer  
Separate  
Trennen

## Maintenance

This element does not require any particular maintenance.

## Sliding hanger

Supports the rails, provides the interval between rails.

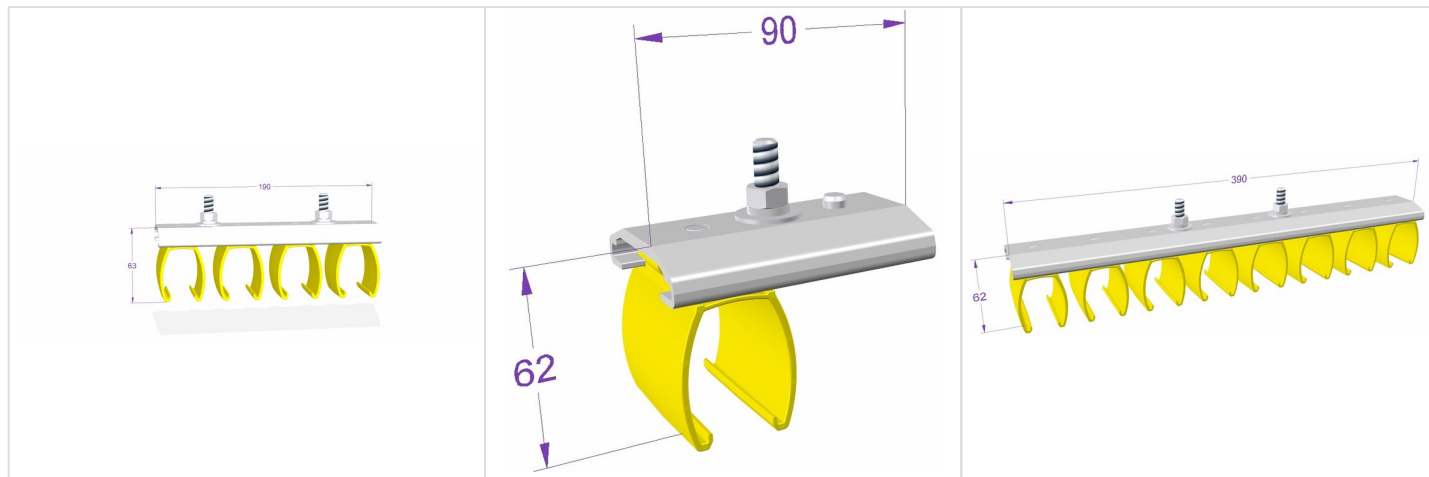

### Description

The suspensions are groups of items of 1 to 8 poles, fully pre-mounted in factory. They are ready for installation. They allow for rail sliding (expansion-retraction phases). Each suspension comprises:- anodized aluminum support of suspension. - thermoplastic parts of suspension depending on the number of poles. - 2 M8 pins which allows fixing on a support. The plastic fixing parts have bent wings to limit the surface of contact with the rail envelope. This limits the retention of water, thereby reducing the strength of sticking between the suspension and the rail due to the white frost or the ice. The suspensions are sized to support the elements of the heaviest rails, fitted with de-icing cable, or the extra stress due to the white frost or to an extra load made by an installer.

### Categorie

Standard

### Avantage n°1

Self-alignment system

### Avantage n°2

Centre to centre clearance of 50mm between conductors

## Références et compatibilités

Number of poles	Reference	Weight	Length
1	MC2501	0,18 kg	90
2	MC2502	0,20 kg	90
3	MC2503	0,25 kg	190
4	MC2504	0,30 kg	190
5	MC2505	0,38 kg	240
6	MC2506	0,46 kg	290
7	MC2507	0,54 kg	340
8	MC2508	0,62 kg	390
<b>Others</b>	Consult us	-	-

## Données techniques

### Données techniques

Centre axis distance of the poles: 50mm

### Encombrement

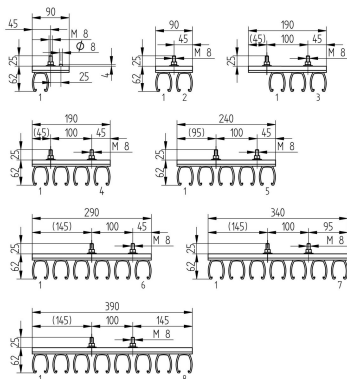

### Poids

see table

<b>Température d'utilisation</b>	-30°C to +55°C	<b>Tension d'emploi</b>	750V
<b>Matière</b>	Anodized aluminium, self-extinguishing thermoplastic, zinc coated steel	<b>Calibre</b>	315A, 450A, 630A

## Montage

### Outils nécessaires au montage



### Outils nécessaires au démontage



( + MC8025 )

### Règle d'installation 1

Position the first sliding hanger at 0.5m of the line end, then every 2 metres. Extra sliding hanger on the last element of the line if line length is >3m.

### Règle de montage 1

Simple clip-on of the rails between the sides of the sliding hanger.

## Règle de montage 2

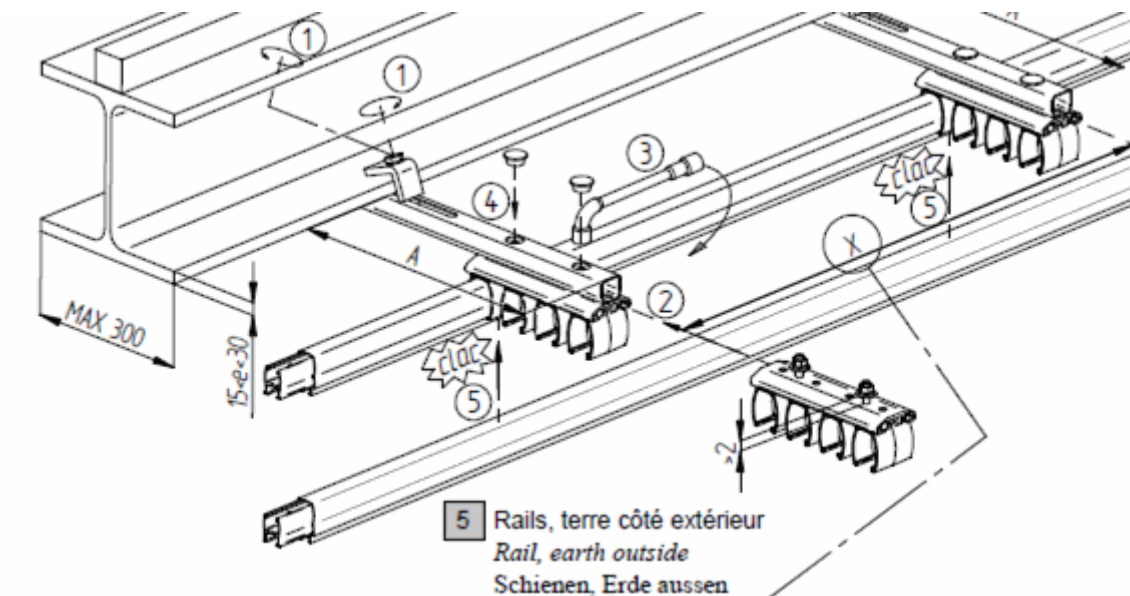

L (m)	L < 1,5	1,5 < L < 4m
	1x	2x
X	/	L/2

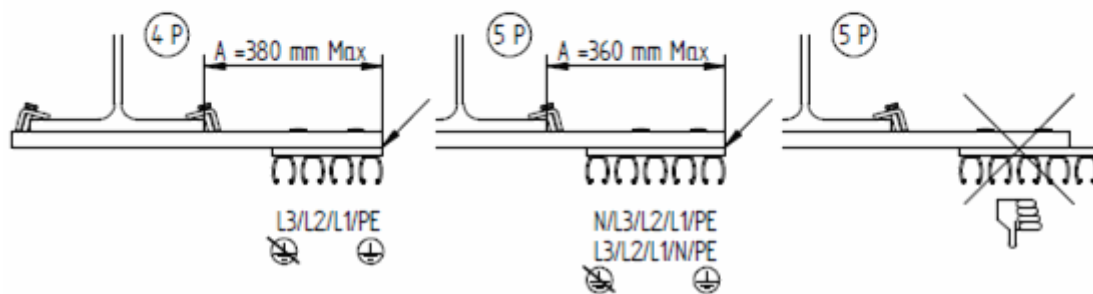
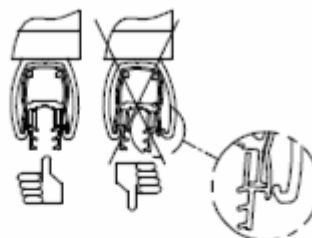

## Maintenance

This element does not require any particular maintenance.

## Fixing clamp

Impedes the displacement of the rails during expansion.



### Description

The fixing clamps immobilise the line longitudinally in relation with the support structure. 2 fixing clamps are required for each pole to make the fixed hanger. For each expansion joint 1 more fixed hanger is needed. For the line to expand freely, the fixed hanger must be placed: - midway on the line when there is no expansion joint. - midway on the sections between expansion joints. A fixed hanger is made of 2 fixing clamps engaged vertically on the rail and which must be stuck on both sides of a sliding suspension, pressing against the suspension support section. Each clamp is dismountable and can be moved to a new position, and the insulating envelope is not damaged. The dimension of the clamps is large enough to make them visible at a distance of several meters from the installation, which facilitates the checking of their position.

### Categorie

Standard

### Avantage n°1

Easily removable

### Avantage n°2

Visible from far away

---

## Références et compatibilités

### Références et variantes

MC2600

---

## Données techniques

## Encombrement

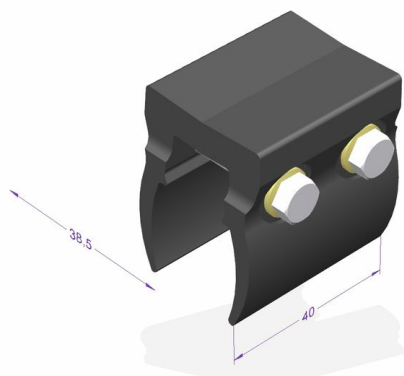

**Encombrement L x H x Z**

33,5 x x 40

**Poids**

0,07 kg

**Température d'utilisation**

-30°C to +55°C

**Calibre**

315A, 450A, 630A

**Matière**

Black painted aluminium, zinc coated steel

## Montage

### Outils nécessaires au montage

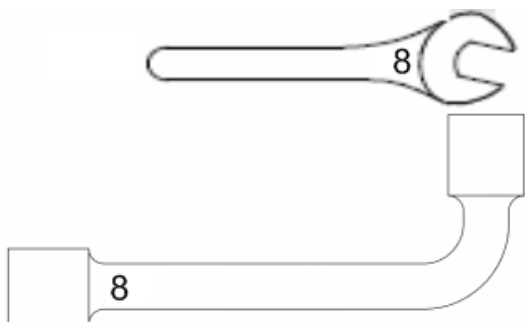

### Outils nécessaires au démontage

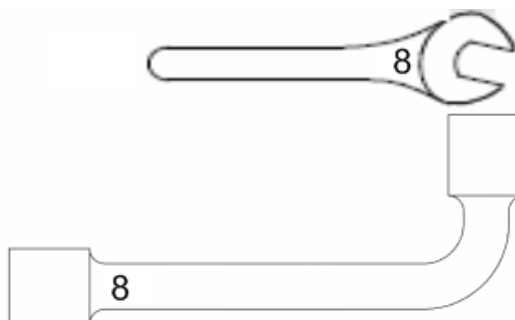

### Règle d'installation 1

Provide a pair of clamps on each pole midway on the line with not expansion joint, or midway of the segment if an expansion joint is fitted (see related section as needed).

### Règle de montage 1

Stick a pair of clamps on both sides of the profile supporting a sliding hanger to provide a fixed hanger.

## Règle de montage 2

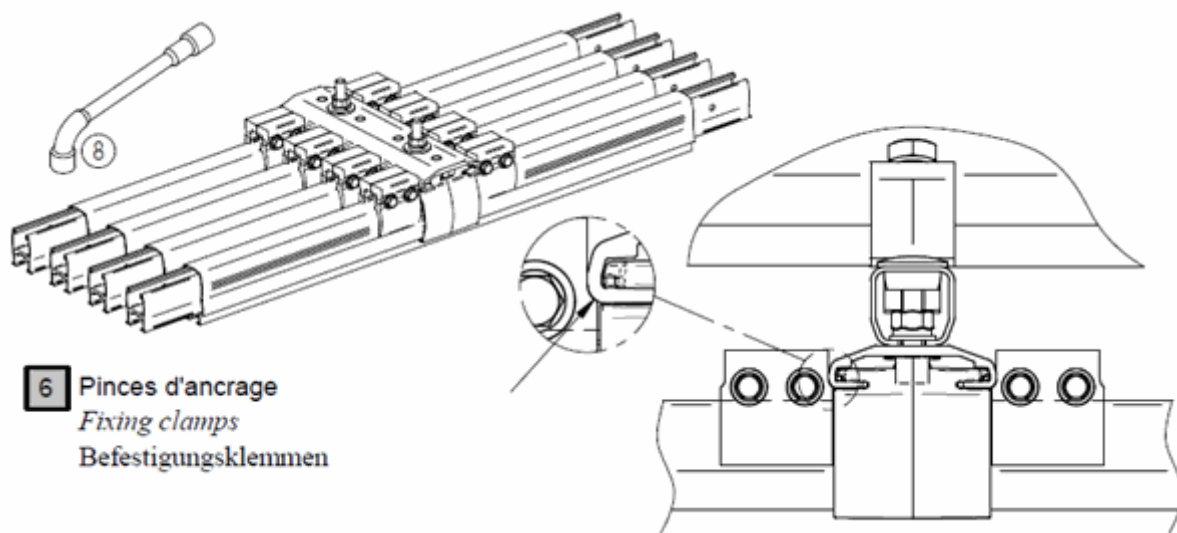

**6** Pincés d'ancrage  
*Fixing clamps*  
Befestigungsklemmen



### Règle de montage 3

Disposition des éléments  
 Layout of the items  
 Anordnung der Teilen

⇒ Ligne sans joint de dilatation / *Line without expansion joint* / Schleifleitung ohne Dehnungsstück

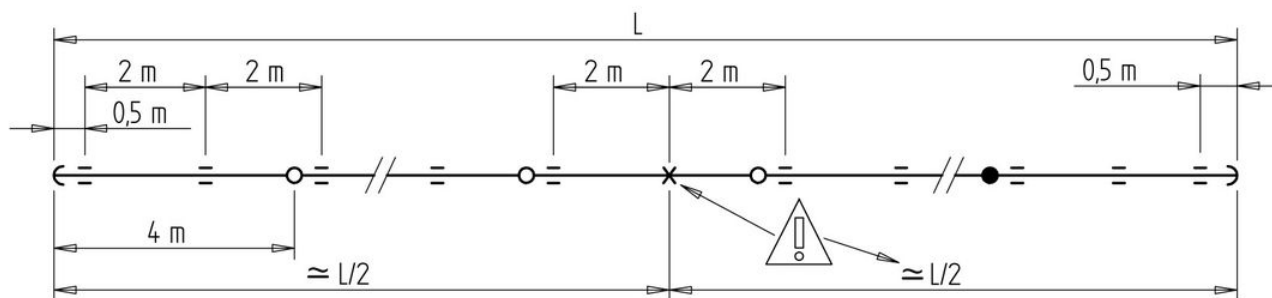

⇒ Ligne avec joint de dilatation / *Line with expansion joint* / Schleifleitung mit Dehnungsstück

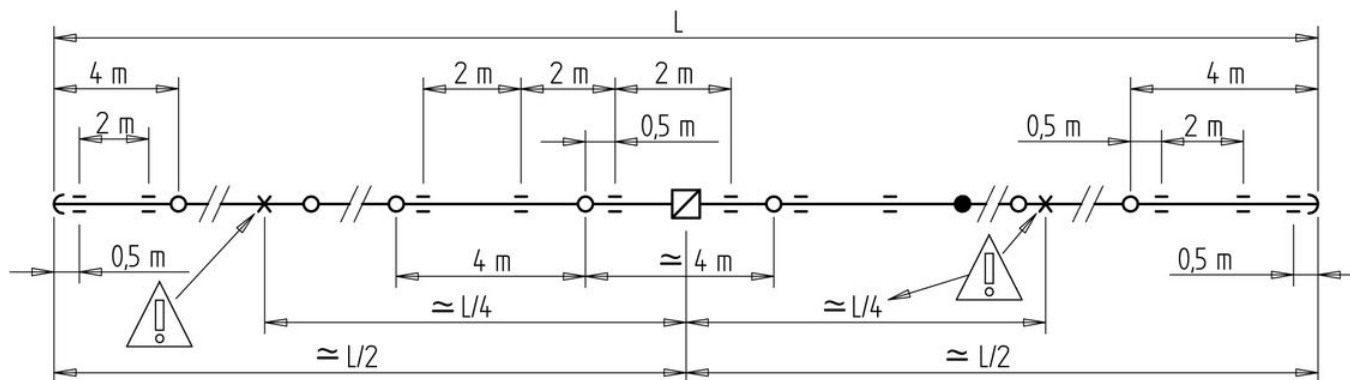

Legende Key Symbol	Vue View Sicht	Élément Item Teil	Page Page Seite
—		Suspension coulissante / <i>Sliding hanger</i> / Gleitaufhängung	- 3 -
X		Suspension avec pinces d'ancrage <i>Suspension with fixing clamps</i> Aufhängung mit Befestigungsklemmen	- 4 -

### Maintenance

This element does not require any particular maintenance.

## Collector

Ensures the electrical connection between the mobile device and the rails.



### Description

The collectors shunt the electrical current to the mobile device requiring power by friction of a carbon brush on the rail track. They shall be installed on a collector bracket that is fixed to the mobile device requiring power. The single-pole 60A model has to be installed in a head to tail position on its support to shunt 120A. 200A model, 400A pre-mounted model, also available. One collector or a set of collectors is required per pole. The earth collector differs from the phase collectors as it has green-yellow markings and a mechanical safety pin to prohibit any contact on a phase, thereby ensuring the safety of the operators. The safety pins can be moved to fit the direction of assembling chosen by the installer. All collectors are delivered with 2-meter flexible cable. The head of the collector is articulated within 2 axes to maintain contact in the varying positions of the collector bracket on which the collectors are mounted. The round shape of the contact track allows to maintain contact even when the collector has a cross slope. The brushes can be replaced when worn out.

### Categorie

Standard

### Avantage n°1

High speed

### Avantage n°2

Optimized contact

## Références et compatibilités

### Références et variantes

The ordering references are as follows. Please note that the earth collector shall be doubled as required by Standard EN60204-32 §13.8.2.

Collector	60A Simple	200A Simple	400A Double
Ref. for phase	MC4162	MC4112	MC4212
Ref. for earth	MC4172*	MC4122*	MC4222
Stationary duty cycle	40% / 5 min 35°C	50% / 5 min 35°C	
Duty cycle in movement	100% at 35°C		100% at 35°C
Weight	1,3 kg	3,85 kg	7,5 kg
Lateral clearance	+/- 30mm	+/- 100mm	
Vertical clearance	+/- 30mm	+/- 50mm	
Included cable section	6 mm <sup>2</sup>	50 mm <sup>2</sup>	
Length of included cable	2 meters		2 meters

\* Mount 2 collectors in parallel

## Données techniques

### Données techniques

Maximum speed of 600 m/min for installations without expansion joint, limited to 270m/min in the expansion joint. With an expansion joint, one double collector above 150m/min for spark-free operation. In vertical position, with rail slot downwards. Horizontal position not feasible with rail slot sideways. Average operating life: 10.000 km depending on alignment quality. Operating life of brushes until replacement: 2000 km.

## Encombrement

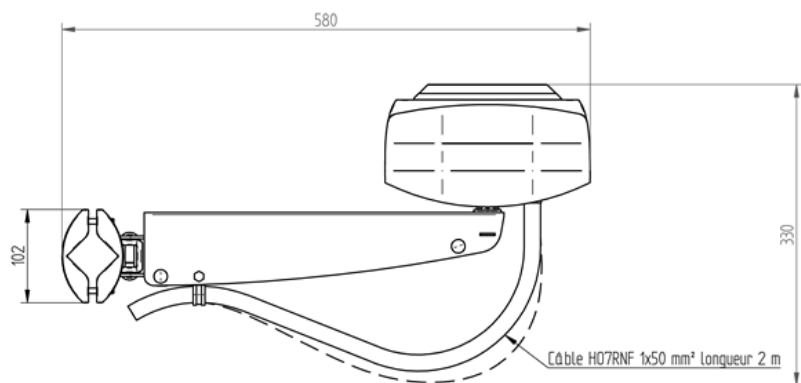

### Encombrement L x H x Z

200A : 50 x 330 x 580 - 60A : 50x240x390

### Poids

According to reference

### Tension d'emploi

750V

### Température d'utilisation

-30°C to +55°C

### Calibre

60-400A

### Matière

Self-extinguishing thermoplastic, anodized aluminium, zinc coated steel

## Montage

### Outils nécessaires au montage

### Outils nécessaires au démontage

60A

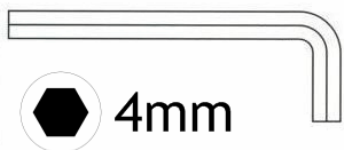

4mm

60A



4mm

200A

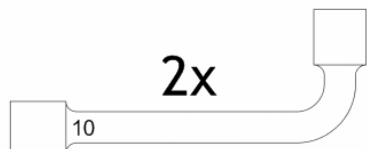

2x

10

200A

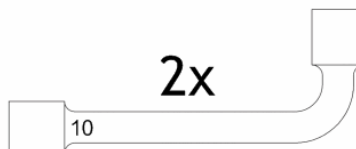

2x

10

### Règle d'installation 1

Insert and take out of the rail only after mains has been cut off. Provides spaces large enough to take the collectors out of the rails and replace the worn brushes.

### Règle de montage 1

To be positioned ideally horizontally. See positioning tolerances in the section 'collector bracket'. The position of the cable should not lower the quality of the contact.

## Règle de montage 2

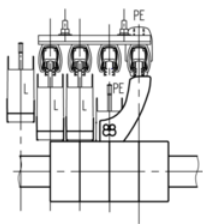
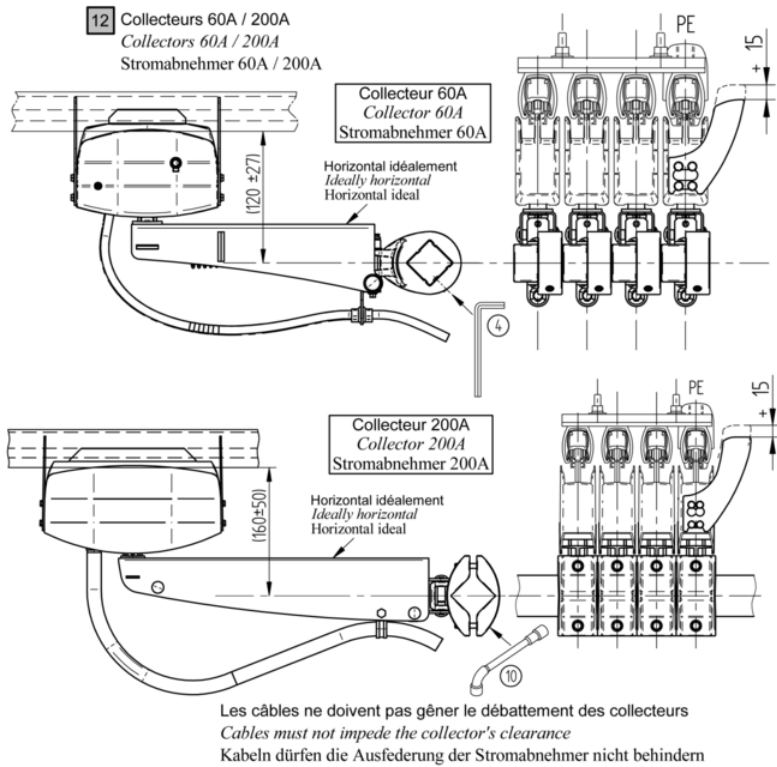

Sécurité / Safety / Sicherheit

Les détrompeurs empêchent la mise en contact accidentelle du collecteur de terre avec un rail de phase  
The mistake-proofing system prevent from accidentally setting in contact the ground collector with a phase rail  
Der Anti-Fehle behindert den zufällige Kontakt zwischen den Stromabnehmer-Erde und eine Phase-Stromschiene

Tolérances de montage, collecteurs en place  
Mounting tolerances, collectors in place  
Montagetoleranzen, Stromabnehmer in Stelle

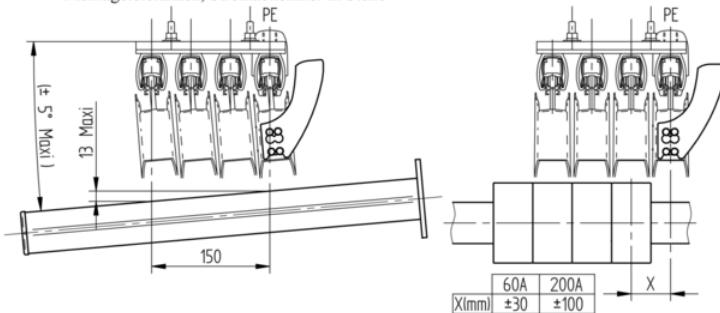

## Maintenance

Check the wear of the brushes periodically: the base of the chamfer is to be used as the indicator of the limit of wear. The average operating life of the brushes is of 2000 km. After the installation has been cut off from mains, pull up the collector box to take it out of the rail. Collector 200A: Pull up the brush to take it out of the box of pantograph and unscrew the bolted connection with the cable, Check that the cable eye stiffener is correctly fitted when reassembling! Replacement of 200A brush: the limit of wear is the base of the chamfer. Collector 60A: Loosen and take the connection screw out of the brush, Remove the worn brush, fit the new one and proceed in reverse order.

Image maintenance



Remplacement du bala 60A : hors tension  
Replacement of the brush 60A : mains switched off  
Ersetzung der Kohle 60A : Strom ausgeschaltet

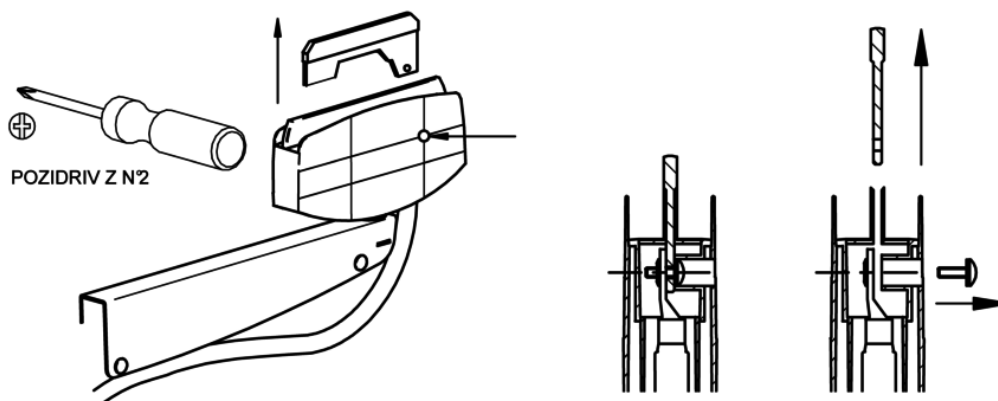

Remplacement du bala 200A : hors tension  
Replacement of the brush 200A : mains switched off  
Ersetzung der Kohle 200A : Strom ausgeschaltet

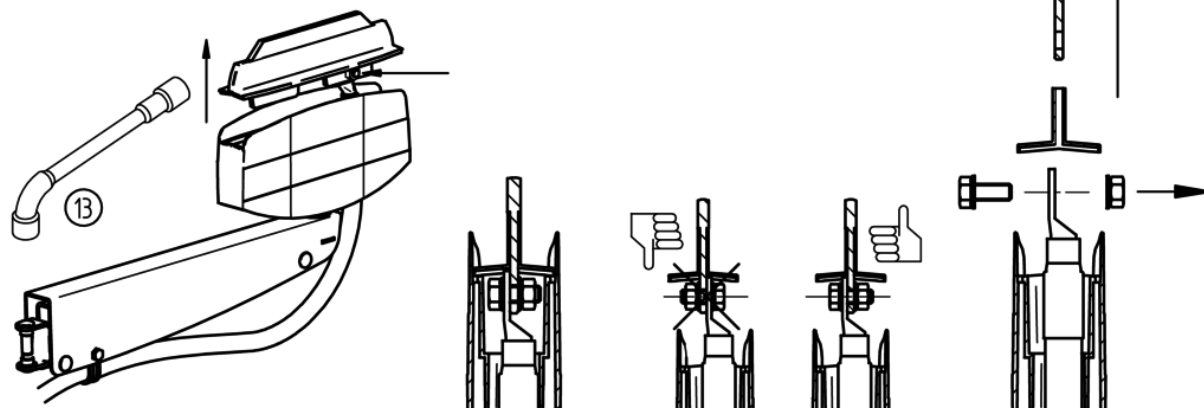

## Collector bracket

Ensures the mechanical link between the mobile device and the collectors.



### Description

The collector bracket is used to support simple or double collectors. It must be firmly fixed to the mobile element requiring power to support the weight and withstand contact forces of the collectors. It sets the position of the collectors on the rails. 2 models are available: a model with tube 40x40 for collectors 200 and 400A and a model with tube 30x30 for collectors 60A.

### Categorie

Standard

### Avantage n°1

Adjustable direction using oblong holes

### Avantage n°2

Same fixing for all models

## Références et compatibilités

### Références et variantes

The following references are available.

### Références et variantes

Reference	For collector	Max. number of poles	Length	Square tube	Weight
MC4900	200A / 400A	8	500 mm	40x40	2 kg
MC4960	60A	8	500 mm	30x30	1,3 kg

# Données techniques

## Données techniques

Assembling by 3 M8 screws. Version with section 40x40: for 8 simple or double collectors 200/400A Version with section 30x30: for 5 double collectors 60A.

## Encombrement

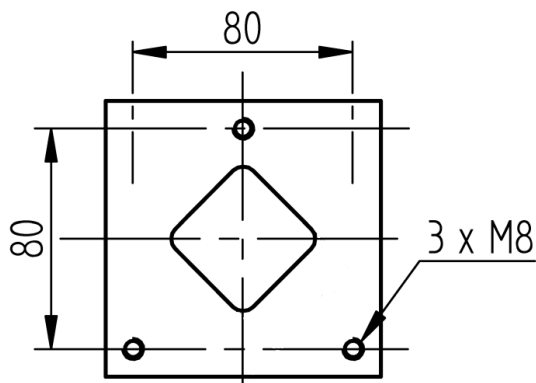

**Encombrement L x H x Z**

100 x 100 x 500

**Poids**

see reference

**Température d'utilisation**

-30°C to +55°C

**Matière**

Galvanized steel

# Montage

## Outils nécessaires au montage



## Outils nécessaires au démontage



## Règle d'installation 1

Use M8 bolts. Install in accordance with the following instructions. Set the height position making provision for future wear of the brushes.

## Règle de montage 1

Use M8 bolts. Install in accordance with the following instructions. Adjust the height position taking into account the future wear of the brushes.



## Règle de montage 2

### 11 Support de collecteur Collector bracket Halterung für Stromabnehmer

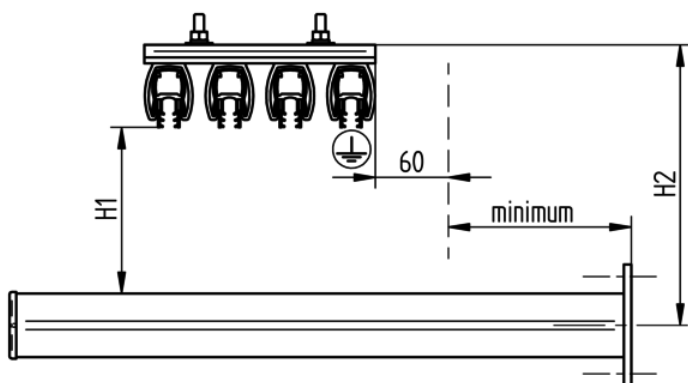

### Fixation du support Fixing of the collector bracket Befestigung der Halterung

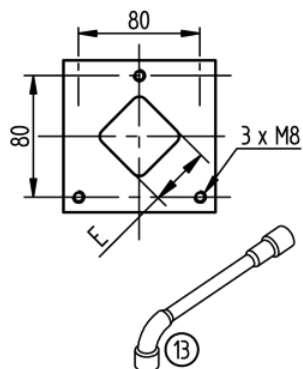

Collecteur collector Stromabnehmer	H1	H2	E
60A	100±27	190±27	30
200A	134±50	230±50	40

### Tolérances de montage, collecteurs en place Mounting tolerances, collectors in place Montagetoleranzen, Stromabnehmer in Stelle

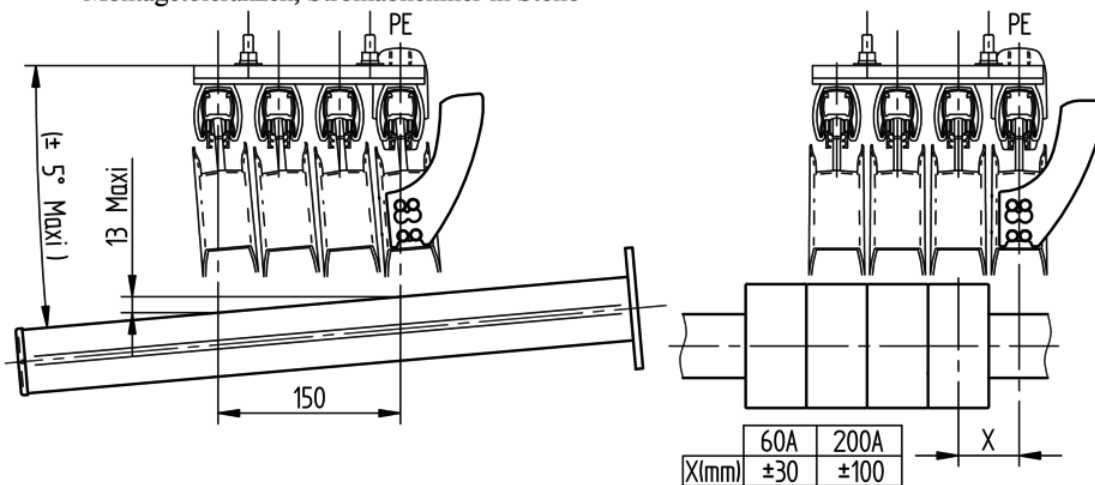

## Maintenance

This element does not require any particular maintenance.

## Bracket

Ensures the mechanical link between the frame structure and the sliding hangers, fixes the position of the line in relation to the running rail.

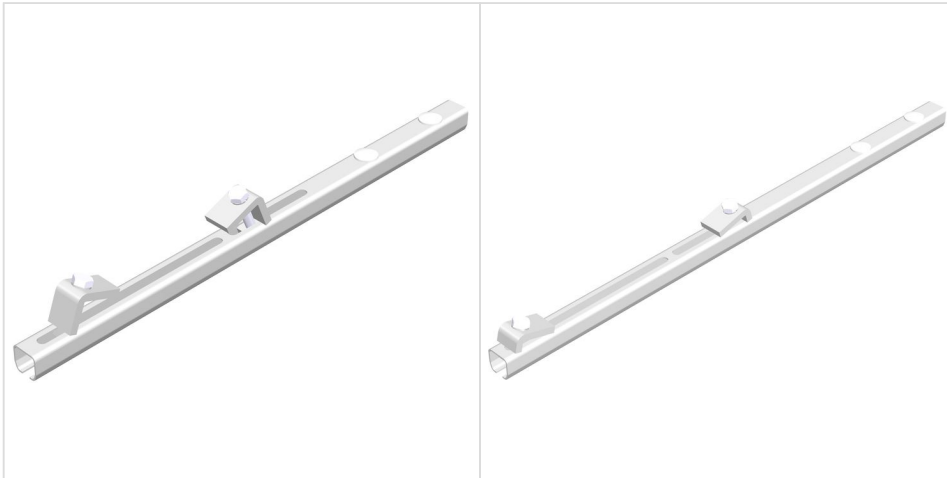

### Description

The bracket sets the clearance between the line and the travel path. This clearance must be as parallel as possible. It carries the sliding suspensions which are slipped into the lower groove and tightened through 2 openings for access. The bracket is available in 2 lengths, 590mm and 700mm. It is designed to fit to the lower part of the beams of a maximum width of 300mm, by tightening 2 lugs. The offset must be adjusted in relation to the running rail. Taking into account the possible load on the supporting elements (weight of the rails + heating cable + unusual loads + white frost), the offset of the rails in relation with the beam should the shortest possible to reduce stresses.

### Categorie

Standard

### Avantage n°1

Available for beam wings of thickness 6 to 32mm

### Avantage n°2



2 lengths available

## Références et compatibilités

### Références et variantes

The following references are available.

### Références et variantes

		Clamping capacity	
Length	Weight	 6 to 20mm	 15 to 32mm
590 mm	1,1 kg	MC2551	MC2550
700 mm	1,3 kg	MC2571	MC2570

# Données techniques

## Données techniques

For tightening on beams IPN, IPE, HEA, HEB, HEM of max. width of 300mm.

## Encombrement

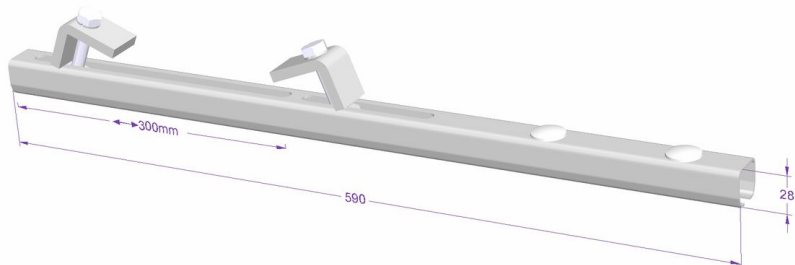

## Encombrement L x H x Z

30 x 28 x L

## Poids

According to reference

## Température d'utilisation

-30°C to +55°C

## Matière

Galvanized steel

# Montage

## Outils nécessaires au montage

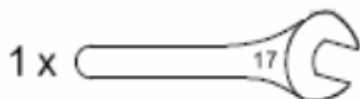

## Outils nécessaires au démontage

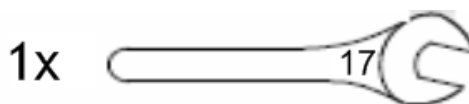

## Règle d'installation 1

Number and position according to the placement rules for sliding hangers.

## Règle de montage 1

Align the assembling holes of the sliding hangers in parallel to the travel path.

## Règle de montage 2

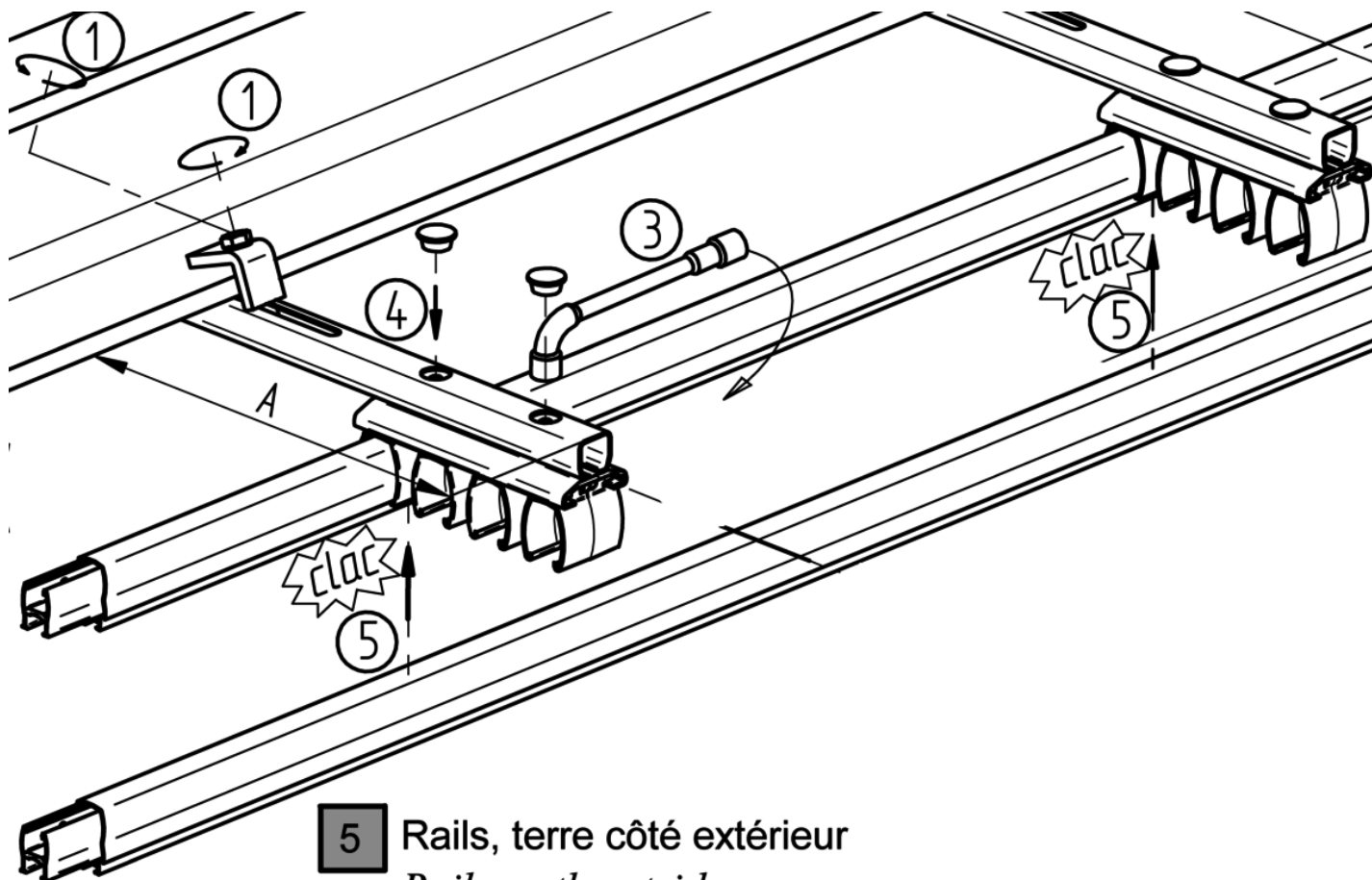

- 5** Rails, terre côté extérieur  
*Rail, earth outside*  
Schienen, Erde aussen

### Maintenance

This element does not require any particular maintenance.

## Expansion joint

Absorbs the difference in expansion between the line and the carrying structure.



### Description

Compensates for the difference in expansion of lines longer than 250 meters, even 350m for lines in non-dusty interior environment and intensities 315A and 450A. The number and the positions of the expansion joints depend on the installation's features and can be determined using our on-line calculator at [www.fels.fr](http://www.fels.fr). It is mounted like a rail element, compact item with height lower than that of the feed box, nominal length of 4 m to be adjusted according to the assembling temperature. Same element for the 3 intensities. The expansion joint is available in phase and earth versions.

### Categorie

Standard

### Avantage n°1

Small overall dimensions

### Avantage n°2

Required only beyond 250m, or even 350m

---

## Références et compatibilités

### Références et variantes

Ref. Phase: MC5614, Ref. Earth: MC5624. These references cover the intensities of 315A, 450A and 630A.

---

## Données techniques

### Données techniques

Maximum speed of a simple collector at the passage of the expansion joint: 270 m/min. Beyond 150m/min, we recommend the use of double collectors. To be supported by 2 sliding suspensions.

### Encombrement L x H x Z

50 x 90 x 4000

### Poids

7,9 kg

### Tension d'emploi

750V

### Température d'utilisation

-30°C to +55°C

### Calibre

315A, 450A, 630A

### Matière

Aluminium, Stainless steel track, self-extinguishing PVC, copper

# Montage

## Outils nécessaires au montage

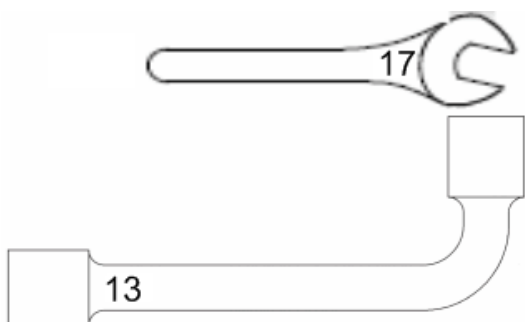

( + MC8025 )

## Outils nécessaires au démontage

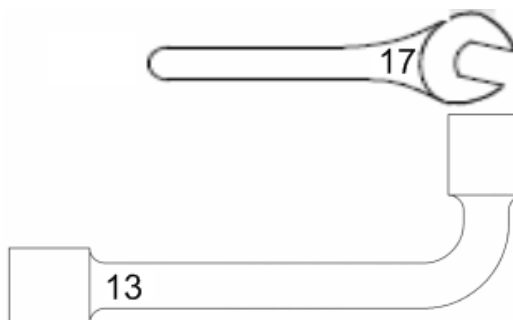

( + MC8025 )

## Règle d'installation 1

General case: Refer to the following diagram and the technical data for the layout of the expansion joints. Special case with curves or circuit interruption elements provided: Refer to these sections.

## Règle de montage 1

To be adjusted imperatively according to the calculation specific to the installation. Always place at mid-point between two fixed hangers.

**13** Joint de dilatation  
Expansion joint  
Dehnungsstück

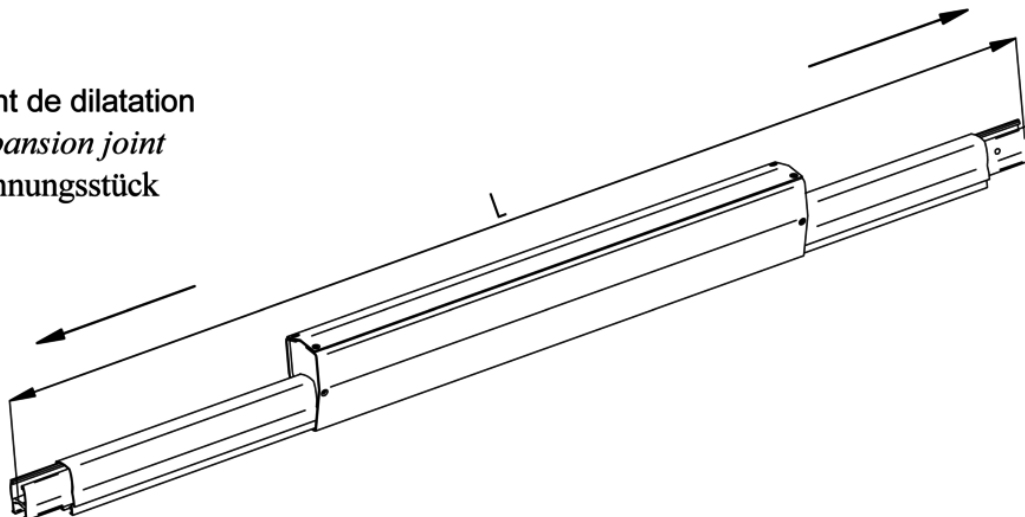

Régler la longueur L au montage en fonction de la température de montage selon la fiche de réglage livrée avec le joint de dilatation.

*By the assembling, please adjust length L depending on ambient temperature according to the adjusting instructions supplied with the expansion joint.*

Die Länge L beim Einbau abhängig von der Umgebungstemperatur nach dem mit dem Dehnungsstück gelieferten Einstellungsblatt einstellen.



Avertissement ! Le nombre de joints de dilatation par pôle et les valeurs de la longueur L données à la livraison sont déterminés en fonction de la longueur de la ligne et des paramètres de service connus. En cas de prolongation de la ligne ou d'augmentation des contraintes de service, le nombre de joints de dilatation doit être vérifié et une nouvelle longueur de réglage L doit être déterminée.



Warning ! The number of expansion joints per pole and the value of the length L given by the delivery of the goods are defined depending on the length of the line and the working conditions known. In case of extension of the line or increase of the working conditions, the number of expansion joint must be checked and a new value L must be defined.



Achtung ! Die Anzahl der Dehnungsstücke per Polen und die Werte für die Länge L die bei der Lieferung angegeben sind wurden gemäss der Länge der Linie und der gekannten Arbeitsdaten bestimmt. Im Falle eine Verlängerung oder bei Erhöhung des Betriebsbedingungen muss die Anzahl der Dehnungsstücke nachgeprüft werden und eine neue Länge L muss gerechnet werden.

**Maintenance**

This element does not require any particular maintenance. Check periodically the continuity of the earth on the expansion joint: once every 2 years.

## Circuit interruption element

Ensures the electrical insulation between 2 sections of the same feeding line.



### Description

Often used to insulate electrically one part of the line from another (maintenance versus work area), allowing for instance maintenance to be carried out on a travelling crane (in a well defined area), while the other cranes continue to run. The circuit interruption element consists of an insulating part located at mid-point on a single conductor rail of 4m length. This element ensures the electrical insulation of the circuits while ensuring the mechanical link of the line. The earth pole should never be interrupted.

### Categorie

Standard

### Avantage n°1

Can be fitted as easily as a straight element

### Avantage n°2

Visual location of the interruption position from the outside

## Références et compatibilités

### Références et variantes

	315A	450A	630A
4m-element, centered interruption	MC1354	MC1454	MC1654
Special element (1)	MC1350	MC1450	MC1650

(1) Special length and/or not centered interruption: complete with length and interruption position informations.



# Données techniques

## Données techniques

Use with 200A and 400A collector only. Double collector are not needed with reduced intensity (50%) on the circuit interruption. An isolation piece guarantees a physical separation of 31 mm between the circuits. Length restriction: see below.

### Maximal length of the line sections with circuit interruption element

1) If the circuit interruption element is located between a fixed point and the end of the line

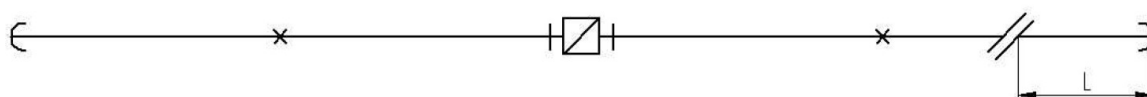

Maximal length L of the line section between the circuit interruption element and the end:

Environment	315A	450A	630A
Normal	120m	120m	80m
Outside or dust	80m	80m	80m

2) If the circuit interruption element is located between a fixed point and an expansion joint

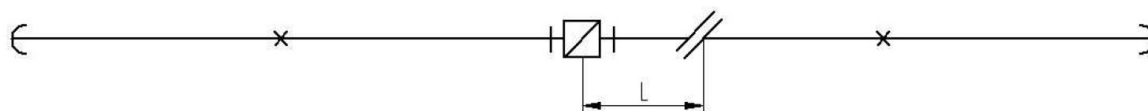

Maximal length L of the line section between the circuit interruption element and the expansion joint:

Environment	315A	450A	630A
Normal	90m	90m	60m
Outside or dust	60m	60m	60m

Key:

-  Expansion joint
-  Circuit interruption

## Encombrement

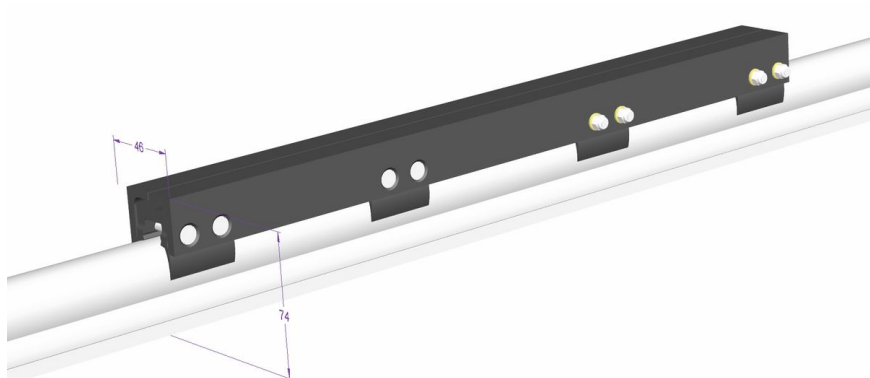

**Encombrement L x H x Z**

46 x 74 x 4000

**Poids**

weight + 0,8 kg

**Tension d'emploi**

750V

**Température d'utilisation**

-30°C to +55°C

**Calibre**

315A, 450A, 630A

**Matière**

Aluminium, Stainless steel track, self-extinguishing PVC Envelope light grey, zinc coated steel

## Montage

**Outils nécessaires au montage**

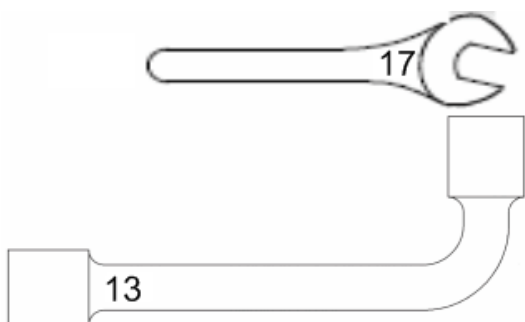

**Outils nécessaires au démontage**

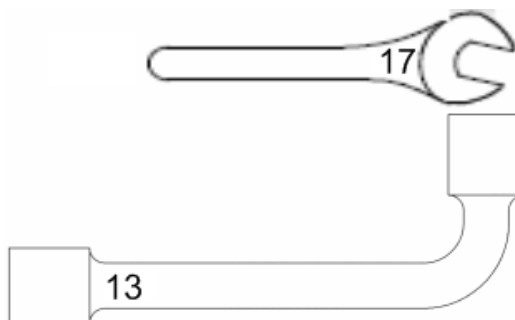

( + MC8025 )

**Règle d'installation 1**

Identical to the standard phase rail.

**Règle de montage 1**

The circuit interruption element is at mid-point of the rail. Position the rail in accordance with the layout provided for the feeding areas. Always prepare the ends of the rails according to our instructions before making the connections.

**Maintenance**

Regular inspection is required to check the insulation between the conductors of the same pole on both sides of the interruption, at least once a year.

## Cable eye stiffeners for feed

For the connection of the cables to the connection screws.



### Description

Galvanized, non-insulated copper cable eye stiffener, for connection to a connection screw by a 10 mm screw.

### Categorie

Accessories

### Avantage n°1

Galvanized copper cable eye stiffener

### Avantage n°2

3 formats available

---

## Références et compatibilités

### Références et variantes

Ref. MC8095 for cables 95mm<sup>2</sup>, Ref. MC8070 for cables 70mm<sup>2</sup>, Ref. MC8050 for cables 50mm<sup>2</sup>.

---

## Données techniques

### Données techniques

Cable eye stiffeners for copper cable.

## Brush for preparation of rail ends

Ensures the preparation of the connection surface of the rail ends.



### Description

Brushing is required to remove the insulating and invisible alumina layer before making the connection.

### Categorie

Accessories

### Avantage n°1

Narrow to facilitate passage between 2 rails

### Avantage n°2

Contributes to connection quality optimization

---

## Références et compatibilités

### Références et variantes

Ref. MC8010

## Contact lubricant

Preserves the quality of the connections of aluminum rails over time.



### Description

The surface of the rail to receive a connection should be greased. After brushing and wiping the particles, the contact lubricant is applied before the connection is fitted in place.

### Categorie

Accessories

### Avantage n°1

Makes connection leakproof

### Avantage n°2

Contains metal particles

---

## Références et compatibilités

### Références et variantes

Ref. MC1010

---

## Données techniques

### Données techniques

Tin with quantity for 200 connections. Safety data sheet on request.

---

## Montage

### Règle de montage 1

To be coated on aluminium surfaces for protection after brushing and wiping. Do not put on the stainless track of the rails.

## Replacement brush for collector

Replacement brush for collector 60A and 200A.



### Description

Allows to replace the collector brush when its lifetime has ended. Brush is identical to the new brushes.

### Categorie

Accessories

### Avantage n°1

Cost-effective

### Avantage n°2

Easy to fit

## Références et compatibilités

### Références et variantes

60A: reference MC0114, 200A: reference MC8041

## Montage

### Règle d'installation 1

Replacement of the brush: the base of the chamfer is the wear limit point.

### Règle de montage 1

Replace the brush after mains voltage cut off! Collector 200A: Pull up the brush to remove it from the case of pantograph and unfasten the bolted connection with the cable, Pay attention to the placement of the cable eye stiffener during reassembly! Collector 60A: Loosen and remove the connection screw of the brush. Remove the brush, replace it, and proceed to the reverse operation.

### Maintenance

Replacement of the brush: the limit of wear is the base of the chamfer.

## Single cleaning collector

Removes the dust and the solid deposits on the track.

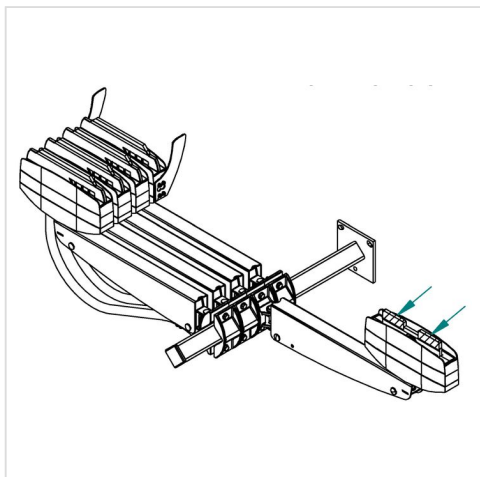

### Description

When a double collector 400A or a simple collector 60A is installed, it is preferable to use cleaning brushes instead of a cleaning collector. Periodic maintenance shall be scheduled (according to environmental conditions, use...) to run the cleaning collector in order to restore the quality of contact between the collector and the conductor.

### Category

Accessories

### Avantage n°1

Allows periodic cleaning of the tracks

### Avantage n°2

Delivered with 1 Cleaner + 1 Grinding tool

---

## Références et compatibilités

### Références et variantes

Ref. MC4190

---

## Données techniques

### Données techniques

Delivered with cleaning brush with abrasive foam and grinding brush with fine grit of 120

### Encombrement L x H x Z

50 x 330 x 580

### Poids

3,8 kg

---

## Montage

### Règle d'installation 1

If a simple collector 200A is installed, symmetrical positioning in relation with the collector bracket.

## Image d'installation

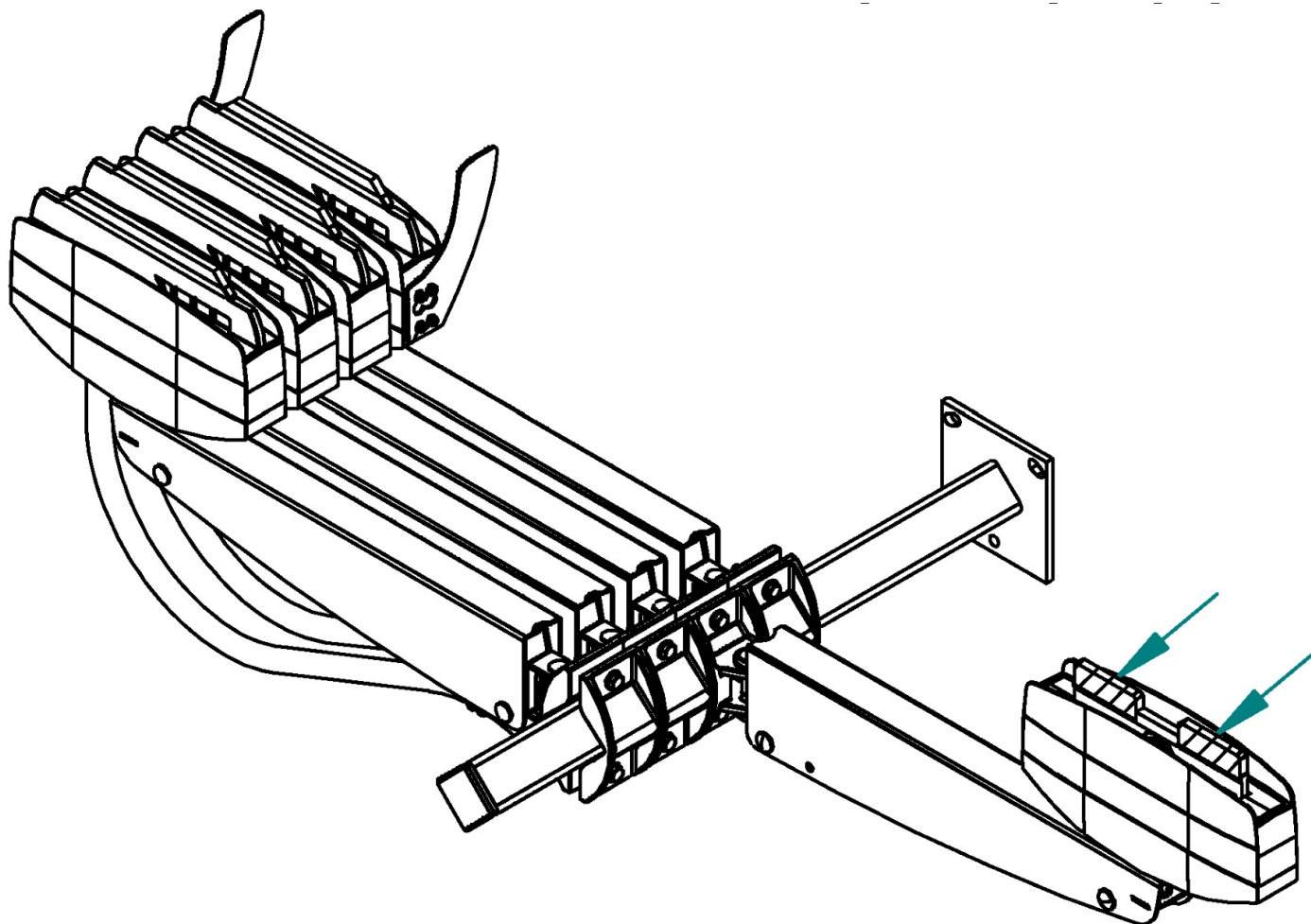

### Règle de montage 1

To be positioned symmetrically opposite to the collector already in place and in relation to the collector bracket. 1. Unscrew the support of the collector in place. Position the cleaning collector and screw 3. Perform the reverse operation for disassembling.

### Maintenance

Simple collectors: fit the cleaning collector in opposite position and clean the rails one by one. Double collectors: replace a collector brush by a maintenance brush, fix the cable to one of the maintenance brushes. Run the cleaning brushes back and forth several times (with abrasive foam) to remove all solid dust particles and deposits, then repeat the operation with the grinding brushes (abrasive grit No. 120) to improve the surface condition of the tracks. Once the lines have been cleaned up, the cleaning collector must be removed as this system is not designed to run over long distances.



## Cleaning and grinding brushes

Renovates the surface condition of the tracks.



### Description

Maintenance accessory used for restoring the surface condition of the tracks, do not use a cleaning collector when the installation includes a double collector 400A or a simple collector 60A.

### Categorie

Accessories

### Avantage n°1

Installed in place of brush

### Avantage n°2

Allows periodic cleaning of the tracks

## Références et compatibilités

### Références et variantes

Cleaning brush Ref. MC8005, grinding brush Ref. MC8006

## Données techniques

### Données techniques

Cleaning brush with abrasive foam and grinding brush with fine grit of 120

## Montage

### Règle d'installation 1

Do not connect a cable to these brushes

### Règle de montage 1

Replace the brush after mains voltage cut off

### Maintenance

Simple collectors: fit the cleaning collector in opposite position and clean the rails one by one. Double collectors: replace a collector brush by a maintenance brush, fix the cable to one of the maintenance brushes. Run the cleaning brushes back and forth several times (with abrasive foam) to remove all solid dust particles and deposits, then repeat the operation with the grinding brushes (abrasive grit No. 120) to improve the surface condition of the tracks. Once the lines have been cleaned up, the collector brush must be put back on as this system is not designed to run over long distances.

## Kit for unclipping sliding hangers

Provides for easy disassembling of the single conductors.



### Description

This kit allows to draw the sliding suspensions apart to remove the single conductor easily.

### Categorie

Accessories

### Avantage n°1

Allows easy disassembling

### Avantage n°2

Saves time

---

## Références et compatibilités

### Références et variantes

Ref. MC8025

---

## Données techniques

### Matière

Self-extinguishing thermoplastic

## Ice shield

Prevents formation of white frost on the track.



### Description

Increases the temperature of the rail by means of a heating cable, thereby preventing the formation of white frost on the surface of the track.

### Categorie

Accessories

### Avantage n°1

Prevents formation of white frost

### Avantage n°2

Fits into the rail

---

## Références et compatibilités

### Références et variantes

Please enquire

---

## Données techniques

### Données techniques

Maximum Length: 2 X 120m, with feeding located midway.

# GAMME HISTORIQUE

**MOBILIS**  
**CE**



**MOBILIS**<sup>®</sup>  
**UNIT**



## Mobilis Elite 200A non -reduced Earth

Straight element intensity 200A 4 poles and 5 poles.

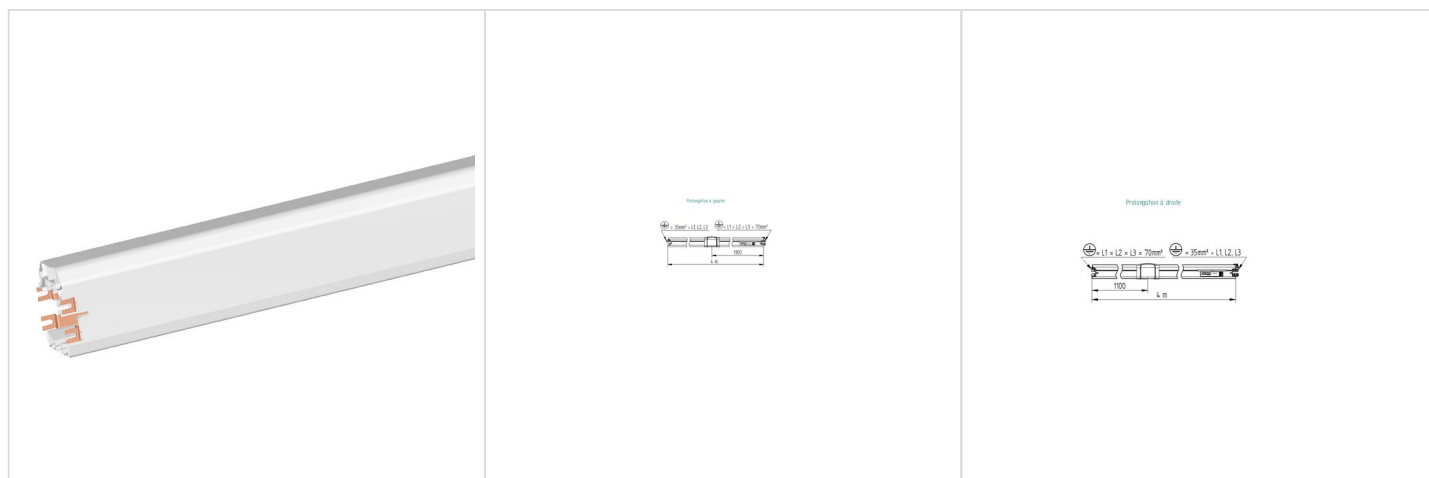

### Description

Mobilis Elite 200A elements with the same copper section for the phase conductors and the protection conductor (Earth) have been no longer supplied as standard version since 2008: they have been replaced by the 200A-TR version with a reduced earthing section, as authorized by standards. They can always be manufactured on request for replacement or a short period of extension of the installation, but not for a long time, it will be cheaper to use an adapter item and to continue extended use with the new 200A-TR version.

### Categorie

Historical range

### Avantage n°1

Earth conductor same as other conductors

### Avantage n°2

IP 23: Index of protection against access to dangerous parts and rain

## Références et compatibilités

### Références et variantes

Straight element of 4 metre length, 4 poles: Ref. ME8284, straight Element of 4 metre length, 5 poles: Ref. ME8285, Adapter element 4 metres, right-hand extension, 4P: ME8275, Adapter element 4 metres, left-hand extension, 4P: ME8276, Adapter element 4 metres, right-hand extension, 5P: ME8277, Adapter element 4 metres, left-hand extension, 5P: ME8278, available in High Temperature version, add - HT after the reference, available in version with dust-protecting lips, add - LV after the reference.

### Disponible avec lèvres ?

oui

### Disponible en version haute température ?

oui

### Disponible en version sans terre ?

non

### Disponible en version courbe ?

oui

## Données techniques

### Encombrement L x H x Z

64 x 90 x 4000

### Tension d'emploi

750V

### Calibre

200A

### Matière

Self-extinguishing PVC light grey or white in HT version

---

# Montage

## Outils nécessaires au montage

## Outils nécessaires au démontage

### Règle d'installation 1

The direction of the extension is identified by looking at the line element with the green-yellow band facing to determine the element of adaptation required for an extension to the right or to the left. The straight elements 200A of 4 meters in version non-TR are supported by 3 sliding hangers in all cases.

### Règle de montage 1

1. Insert the lines in the sliding hangers, 2. Connect the lines

### Règle de montage 2

## 6 Connexion des conducteurs

Connection of conductors

Verbindung der Leiter

- 12A → 130A  
PE 160A / PE 200A TR :

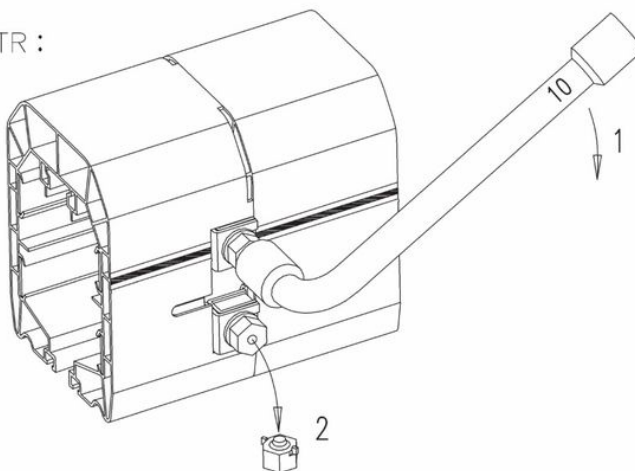
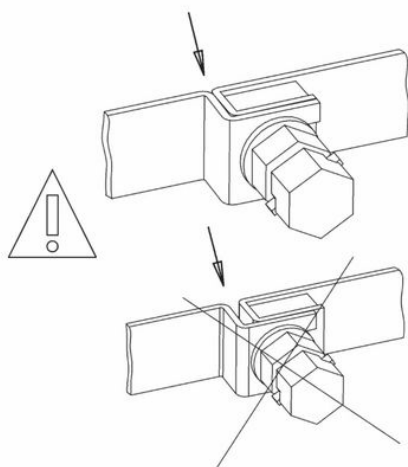

**Serrer jusqu'à rupture des têtes de vis**  
*Tighten until the screw heads break*  
Anziehen, bis die Schraubenköpfe brechen



**Connecter les conducteurs 40A avec précaution**  
*Connect the 40A-conductors cautiously*  
40A-Leiter vorsichtig verbinden

- 160A → 200A :

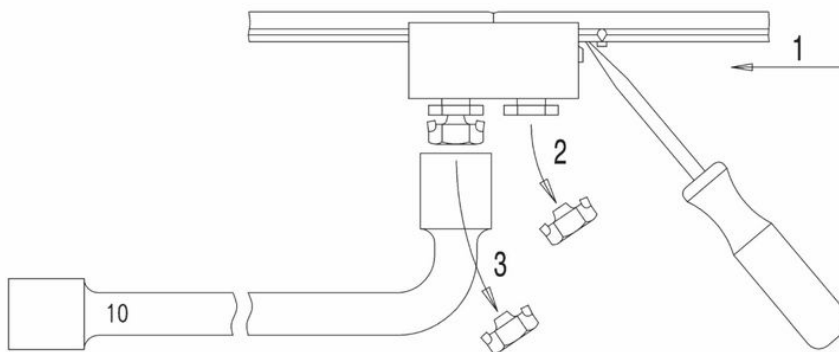
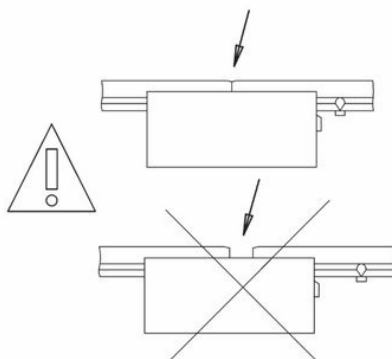

## Maintenance

See the rules of maintenance of the lines

## Obsolete range MOBILIS CE

Multi-conductor line of 4 to 7 poles until 2005.



### Description

The Mobilis range CE was sold from 1978 to 2005. Some spare parts can still be supplied.

### Categorie

Historical range

### Avantage n°1

Intensities 40A, 60A, 100A, 130A, 200A, color gray anthracite or white (High temperature range).

### Avantage n°2

High impact resistance



## Trolley with cable Mobilis CE

Replacement trolley for rectilinear lines Mobilis CE 4 and 5 poles.

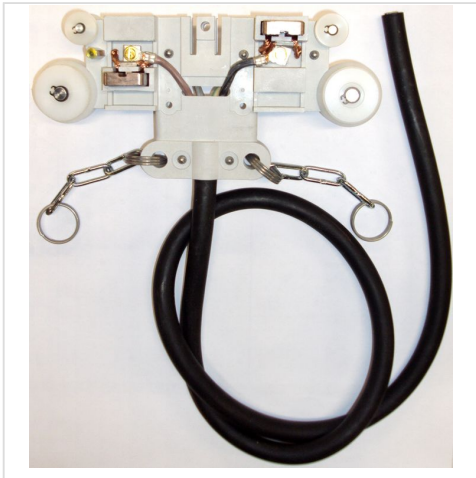

### Description

Polyamide rollers on steel axes. Safety pin. Driving chains with attachment spring ring. Prewired.

### Categorie

Historical range

### Avantage n°1

to be used in replacement of trolleys with cable outlet or box outlet

### Avantage n°2

equipped with 4mm 131 cable of 1 meter

## Références et compatibilités

### Références et variantes

Trolley 4 Poles Ref. MO2043, Trolley 5 Poles Ref. MO2051

## Données techniques

### Données techniques

The trolleys are delivered with cable HO7RNF 4 or 5G4 of 1mv length. Max speed of 100m/min.

### Encombrement L x H x Z

46 x 103 x 220

### Calibre du chariot

40A

### Tension d'emploi

500V

### Température d'utilisation

-20°C to +75°C

## Standard brushes for carriage mobilis CE

Replacement part for collector trolley outside circuits with transfer elements, for power conductors.

**Description**

Brush with braid and connection plate to be screwed

**Categorie**

Historical range

**Avantage n°1**

Brushes 40A

**Avantage n°2**

1 brush per pole

---

## Références et compatibilités

**Références et variantes**

MO3407

---

## Données techniques

**Données techniques**

The dimensions shown are those of the brush only

**Encombrement L x H x Z**

27 x 24 x 7,6

**Tension d'emploi**

500V

**Température d'utilisation**

-20°C to +55°C

**Calibre**

40A

**Matière**

self-lubricating carbon brushes

---

## Montage

**Règle d'installation 1**

S'assurer du bon état des pistes de frottement des conducteurs avant de remplacer les balais.

# Brushes of trolleys mobilis CE for lines with transfer element

Replacement part for the auxiliary poles of collector trolleys 6 and 7 poles.

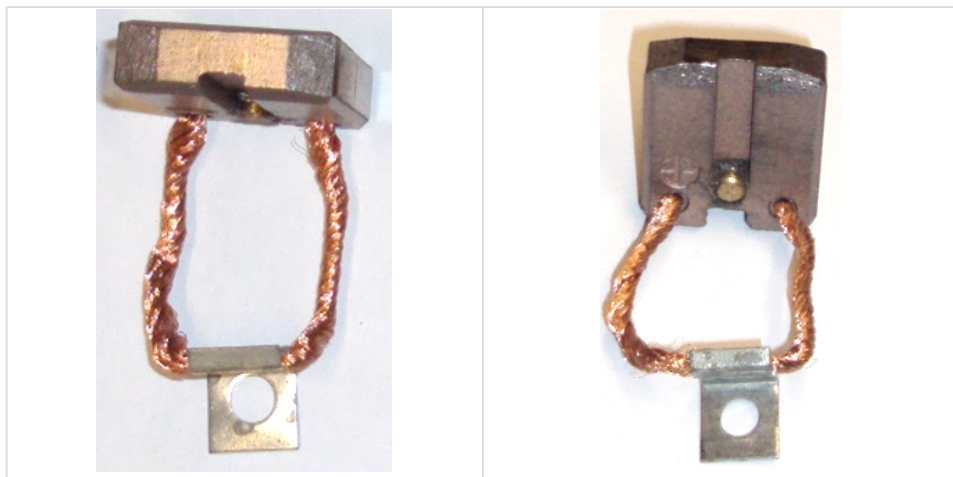

### Description

This brush is fitted with a reinforced stop to withstand the shocks of expulsion on repeated passages in the transfer elements.

### Categorie

Historical range

### Avantage n°1

reinforced stop

### Avantage n°2

1 brush per pole

## Références et compatibilités

### Références et variantes

MO3427

## Données techniques

### Données techniques

The dimensions shown are those of the brush only

### Encombrement L x H x Z

27 x 24 x 7,6

### Tension d'emploi

500V

### Température d'utilisation

-20°C to +55°C

### Calibre

40A

### Matière

self-lubricating carbon brushes

## Montage

### Règle d'installation 1

S'assurer du bon état des pistes de frottement des conducteurs avant de remplacer les balais.

# Remote control brush Mobilis CE

brush for the auxiliary poles of trolleys 6 and 7 poles.

**Description**

Pre-fitted with spring and connection bar

**Categorie**

Historical range

**Avantage n°1**

Self-lubricating brush

**Avantage n°2**

1 brush per pole

---

## Références et compatibilités

**Références et variantes**

MO6204

---

## Données techniques

**Données techniques**

The dimensions shown are those of the brush only

**Encombrement L x H x Z**

28 x 20 x 5

**Tension d'emploi**

48V

**Température d'utilisation**

-20°C to +55°C

**Calibre**

10A

**Matière**

self-lubricating carbon brushes

# Obsolete range MOBILIS UNIT

Single conductor rail 2 to 5 poles.

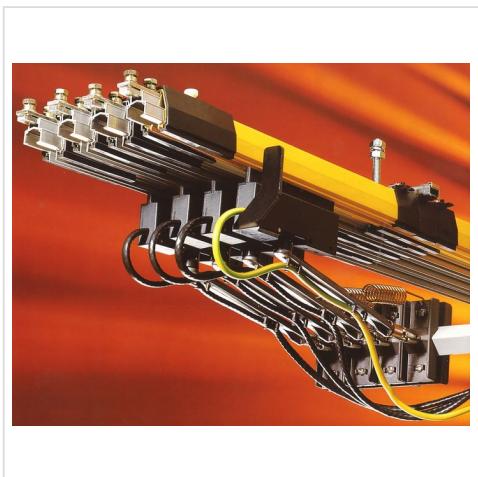

### Description

The Mobilis range UNIT was in sale from 1985 to 2005. Some spare parts can still be supplied.

### Categorie

Historical range

### Avantage n°1

Intensities 250A and 320A

### Avantage n°2

Aluminium rails with stainless track and single-arm collectors

# Brush for pantograph 100A Mobilis UNIT

Replacement part for collectors 100A reference MU4000 and 4050.



### Description

This type of brush is connected by connector in the collector, it is assembled/dismounted by assembling - extraction.

### Categorie

Historical range

### Avantage n°1

No tool required for assembling and disassembling

### Avantage n°2

2 brushes per collector

---

## Références et compatibilités

### Références et variantes

MU4031

---

## Données techniques

### Encombrement L x H x Z

50 x 45 x 5

### Calibre du pantographe

100A

### Tension d'emploi

500V

### Température d'utilisation

-20°C to +55°C

### Matière

self-lubricating carbon brushes

# Garanties

Notre matériel est garanti un an contre tout vice de matière ou de fabrication reconnu par nous-mêmes. N'étant pas maîtres des conditions de montage et d'exploitation, notre garantie se limite au remplacement ou à la réparation (à notre choix) de l'élément reconnu défectueux. Notre responsabilité ne saurait être engagée en cas de défaut de surveillance et d'entretien. De même que les arrêts de production ne sauraient nous être imputés. En cas de litige, les tribunaux de Strasbourg sont seuls compétents, même en cas de pluralité des défendeurs.